

POWER TOOLS

OVERVIEW**492-493****CORDLESS****494-519****AIR****520-550****ACCESSORIES****551-576**

CT861
14.4 V 3/8" Drive MicroLithium
Cordless Impact Wrench



*“Snap-on makes power tools
that fit into places most others
can’t. So I can work in tight
spaces with minimum setup.”*

*George
George’s Auto Repair*

CDR9050
18 V 1/2" MonsterLithium Cordless Hammer Drill

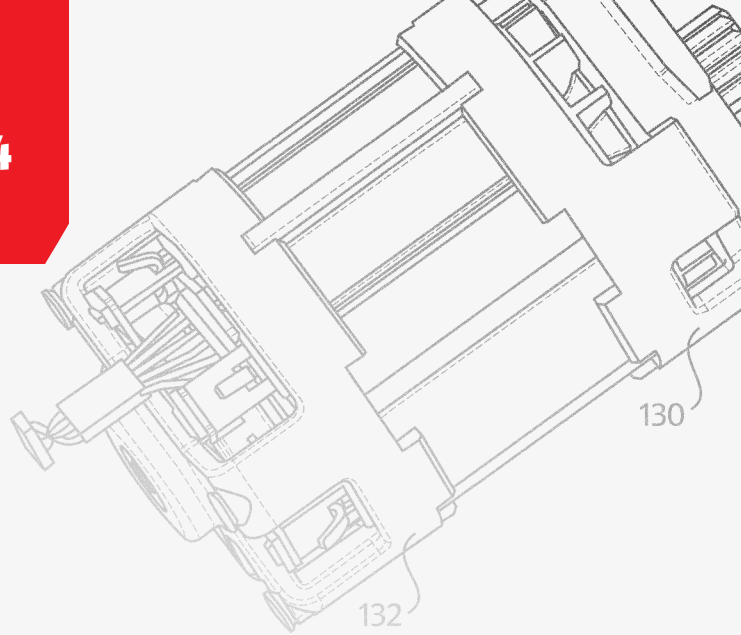

Fig. 5

POWER TOOLS DRIVEN BY CONTINUOUS IMPROVEMENT.



PT350
1/2" Drive Stubby Air Impact Wrench

Never underestimate the power of innovation. Snap-on® power tools deliver power, comfort and control, with designs from compact bodies to long necks to deliver the accessibility you need. And thanks to the conversion to brushless motors, our cordless power tools run cooler, safer and longer than ever before. Add in superior ergonomics, and you have some very powerful reasons to choose Snap-on.

CORDLESS: QUICK REFERENCE CHART

Impacts

Specifications	CT9100K2	CT9080K2	CT9050K2	CT9015K2	CT9010K2	CT861K2	CT825K2
Battery Type	Lithium 5.0 Ah	Lithium 5.0 Ah	Lithium 5.0 Ah	Lithium 5.0 Ah	Lithium 5.0 Ah	Lithium 2.5 Ah	Lithium 2.5 Ah
Battery Voltage	18	18	18	18	18	14.4	14.4
Square Drive, inches (mm)	3/4 (19)	1/2 (13)	1/2 (13)	1/2 (13)	3/8 (10)	3/8 (10)	1/4 (6)
Torque Output, ft-lb (N•m)	1,000 (1,355)	1,050 (1,423)	800 (1,085)	240 (325)	240 (325)	150 (203)	70 (95)
Blows Per Minute, BPM	2,200	2,300	2,300	3,520	3,520	3,000	3,000
Free Speed, RPM	1,570	1,570	2,000	1,760	1,760	2,500	2,200
Height with Battery, inches (mm)	10.5 (267)	10.5 (267)	10.25 (260)	10 (254)	10 (254)	8.0 (203)	8.0 (203)
Length, inches (mm)	10.3 (261)	9.6 (244)	8.2 (208)	6.7 (170)	6.7 (170)	6.8 (173)	6.8 (173)
Weight with Battery, lb (kg)	8.9 (4.04)	8.2 (3.7)	6.5 (2.9)	4.9 (2.22)	4.9 (2.22)	2.7 (1.2)	2.7 (1.2)
Charge Time, minutes	90	90	90	90	90	70	70
Warranty (battery)	2 Years/1,000 Cycles	2 Years/1,000 Cycles	2 Years/1,000 Cycles	2 Years/1,000 Cycles	2 Years/1,000 Cycles	1 Year	1 Year
Warranty (tool and charger)	2 Years	2 Years	2 Years	2 Years	2 Years	1 Year	1 Year
Pinned Anvil Version	—	—	CT9050P	—	CT9010P	—	—
Quick-Change Chuck Version (hex size of chuck)	—	—	—	—	—	CTQ861 (1/4")	—
Tool Only	CT9100DB	CT9080DB	CT9050DB	CT9015DB	CT9010DB	CT861DB	CT825DB

CE

Drills/Drivers

Specifications	CDR9015K2	CDR9050K2	CDR861K2*	CDRR2005360K2	CDRR200545K2	CDRR2005K2	CDRR761K2	CDRS761K2
Battery Type	Lithium 5.0 Ah	Lithium 5.0 Ah	Lithium 2.5 Ah	Lithium 2.5 Ah	Lithium 2.5 Ah	Lithium 2.5 Ah	Lithium 2.5 Ah	Lithium 2.5 Ah
Battery Voltage	18	18	14.4	14.4	14.4	14.4	14.4	14.4
Chuck Capacity, inches (mm)	1/2 (13)	1/2 (13)	3/8 (10)	1/4"-28	1/4"-28	1/4"-28	3/8 (10)	3/8 (10)
Torque Output in-lb (N•m)	470 (53.1)	470 (53.1)	200 (22.6)	12 (1.355)	12 (1.355)	12 (1.355)	150 (16.9)	65 (7.3)
Clutch Settings	18 Plus Drill	23	9	—	—	—	9	9
Gear Box Type	2-Speed	2-Speed	2-Speed	Single-Speed	Single-Speed	Single-Speed	2-Speed	2-Speed
RPM (low)	420	420	450	—	—	—	450	450
RPM (high)	2,000	2,000	1,550	6,000	6,000	6,000	1,550	1,550
Length, inches (mm)	7.6 (193)	8.1 (205)	7.7 (198)	12 (305)	12 (305)	12 (305)	13.3 (338)	13.3 (338)
Weight with Battery, lb (kg)	5 (2.27)	5.1 (2.3)	2.4 (1.1)	1.4 (.64)	1.4 (.64)	1.4 (.64)	3.3 (1.5)	2.6 (1.2)
Charge Time, minutes	90	90	70	70	70	70	70	70
Warranty (battery)	2 Years	2 Years	1 Year	1 Year	1 Year	1 Year	1 Year	1 Year
Warranty (tool and charger)	2 Years	2 Years	1 Year	1 Year	1 Year	1 Year	1 Year	1 Year
Tool Only	CDR9015DB	CDR9050DB	CDR861DB	CDRR2005360DB	CDRR200545DB	CDRR2005DB	CDRR761DB	CDRS761DB

*UL® listed.

CE

Die Grinders

Specifications	CTGRS8806AK1	CTGRS8825AK1	CGRR861K2	CGRS861K2
Battery Type	Lithium 5.0 Ah	Lithium 5.0 Ah	Lithium 2.5 Ah	Lithium 2.5 Ah
Battery Voltage	18	18	14.4	14.4
Free Speed, RPM	6,000	25,000	9,500-28,000	10,000-30,000
Charge Time, minutes	90	90	70	70
Height with Battery, inches (mm)	4 (102)	4 (102)	3.3 (84)	3.3 (84)
Width with Battery, inches (mm)	3 (76)	3 (76)	2 (50)	2 (50)
Length, inches (mm)	11.4 (290)	11.4 (290)	11.4 (290)	11.4 (290)
Weight with Battery, lb (kg)	4.9 (2.2)	4.6 (2.1)	2.2 (0.99)	1.7 (.77)
Warranty (tool and charger)	2 Years	2 Years	1 Year	1 Year
Warranty (battery)	2 Years	2 Years	1 Year	1 Year
Tool Only	CTGRS8806ADB	CTGRS8825ADB	CGRR861DB	CGRS861DB

CE

Angle Grinders

Specifications	CTGR8850AK1	CTGR8855AK1
Battery Type	Lithium 5.0 Ah	Lithium 5.0 Ah
Battery Voltage	18	18
Wheel Size, inches (mm)	4.5 (114) or 5 (127)	4.5 (114) or 5 (127)
Arbor Size, inches (mm)	7/8 (22)	7/8 (22)
Free Speed, RPM	8,000	8,000
Charge Time, minutes	90	90
Switch Type	Slide Switch	Safety Switch
Length w/battery, inches (mm)	16.5 (419)	16.5 (419)
Weight with Battery, lb (kg)	6.2 (2.8)	6.2 (2.8)
Warranty (tool and charger)	2 Years	2 Years
Warranty (battery)	2 Years/1,000 Cycles	2 Years/1,000 Cycles
Tool Only	CTGR8850ADB	CTGR8855ADB

K2 = US J2 = Japan U2 = Europe Z2 = Australia

Ratchets

Specifications	CTR814K2	CTR817K2	CTR861K2	CTR867K2	CTR762K2	CTR768K2
Battery Type	Lithium 2.5 Ah	Lithium 2.5 Ah	Lithium 2.5 Ah	Lithium 2.5 Ah	Lithium 2.5 Ah	Lithium 2.5 Ah
Battery Voltage	14.4	14.4	14.4	14.4	14.4	14.4
Charge Time, minutes	70	70	70	70	70	70
Square Drive, inches (mm)	1/4 (6)	1/4 (6)	3/8 (10)	3/8 (10)	3/8 (10)	3/8 (10)
Torque Output, ft-lb (N•m)	35 (47)	35 (47)	60 (81)	60 (81)	70 (95)	70 (95)
Manual Torque, ft-lb (N•m)	46 (62)	46 (62)	158 (214)	158 (214)	158 (214)	158 (214)
Free Speed, RPM	350	350	275	275	175	175
Height with Battery, inches (mm)	11.1 (282)	13.9 (353)	12.2 (310)	15.6 (396)	12.8 (324)	16.2 (411)
Weight with Battery, lb (kg)	2 (0.9)	2.4 (1.1)	2.7 (1.2)	3.3 (1.5)	2.8 (1.3)	3.5 (1.5)
Warranty (battery)	1 Year	1 Year	1 Year	1 Year	1 Year	1 Year
Warranty (tool and charger)	1 Year	1 Year	1 Year	1 Year	1 Year	1 Year
Battery (qty)	CTB8174 (2)	CTB8174 (2)	CTB8174 (2)	CTB8174 (2)	CTB8174 (2)	CTB8174 (2)
Battery Charger	CTC772A	CTC772A	CTC772A	CTC772A	CTC772A	CTC772A
Tool Only	CTR814DB	CTR817DB	CTR861DB	CTR867DB	CTR762DB	CTR768DB

CE

Screwdrivers

Specifications	CTS861K2	CTSR761K2	CTSS761K2
Style	Pistol	Inline	Inline
Battery Type	Lithium 2.5 Ah	Lithium 2.5 Ah	Lithium 2.5 Ah
Battery Voltage	14.4	14.4	14.4
Trigger Style	Toggle	Paddle	Paddle
Charge Time, minutes	70	70	70
Chuck Cap., inches (mm)	1/4 (6)	1/4 (6)	1/4 (6)
Square Drive, inches (mm)	1/4 (6) Hex	1/4 (6) Hex	1/4 (6) Hex
Torque Output, in-lb (N•m)	200 (22)	150 (16.9)	65 (7.3)
Clutch Settings	9	9	9
Gear Box Type	2-Speed	2-Speed	Single Speed
Free Speed, RPM	450/1,550	450/1,550	0-1,350
RPM (low)	0-450	0-450	—
RPM (high)	0-1,550	0-1,550	—
Length, inches (mm)	6.1 (155)	13.3 (338)	11.8 (300)
Width, inches (mm)	1.9 (48)	2 (50.8)	2 (50.8)
Height, inches (mm)	7.8 (198)	3.3 (84)	3.3 (84)
Weight with Battery, lb (kg)	2.1 (1.0)	2.7 (1.2)	2.2 (1.0)
Warranty (battery)	1 Year	1 Year	1 Year
Warranty (tool and charger)	1 Year	1 Year	1 Year
Battery (qty)	CTB8174 (2)	CTB8174 (2)	CTB8174 (2)
Battery Charger	CTC772A	CTC772A	CTC772A
Tool Only	CTS861DB	CTSR761DB	CTSS761DB

CE

Reciprocating Saw

Specifications	CTRS8850AK1	CTRS761AK2
Battery Type	Lithium 5.0 Ah	Lithium 2.5 Ah
Battery Voltage	18	14.4
Stroke Length, inches (mm)	1 (25.4)	1/2 (13)
Strokes Per Minute	2,400	3,100
Length, inches (mm)	18 (457)	12 (304)
Height with Battery, inches (mm)	8.25 (210)	—
Weight with Battery Pack (Li-Ion), lb (kg)	7.7 (3.4)	3.2 (1.5)
Variable Speed Switch	—	Yes
Charge Time, minutes	90	70
Warranty (battery)	2 Years/1,000 Cycles	1 Year
Warranty (tool and charger)	2 Years	1 Year
Battery (qty)	CTB185 (1)	CTB8174 (2)
Battery Charger	CTC131	CTC772A
Tool Only	CTRS8850ADB	CTRS761ADB

K2 = US J2 = Japan U2 = Europe Z2 = Australia



• Read and follow safety messages for each type of Cordless Tool on the following pages and the safety precautions on pages W1-W4

CORDLESS: 18-VOLT BRUSHLESS IMPACT WRENCHES



CT9100K2



CT9080K2

CT9100 Series 18 V 3/4" Drive Impacts

Specifications	CT9100K2
Battery Type	Lithium 5.0 Ah
Battery Voltage	18
Charge Time, minutes	90
Square Drive, inches (mm)	3/4 (19)
Torque Output, ft-lb (N•m)	1,000 (1,355)
Blows Per Minute, BPM	2,200
Free Speed, RPM	1,570
Height with Battery, inches (mm)	9.5 (241)
Length, inches (mm)	10.3 (261)
Weight with Battery, lb (kg)	8.9 (4.04)
Warranty (battery)	2 Years/1,000 Cycles
Warranty (tool and charger)	2 Years
Battery (qty)	CTB185 (2)
Battery Charger	CTC131
Optional Protective Boot	CT9100BOOT
Tool Body Only	CT9100DB

CT9100K2 18 V 3/4" Drive MonsterLithium Cordless Impact Wrench Kit

- 1,000 ft-lb (1,355 N•m) of torque output
- 1,300 ft-lb (1,763 N•m) of bolt breakaway torque
- Three torque setting adapt to various applications
- Cerakote premium nose resists abrasion
- Brushless motor for longer runtime and durability
- Super bright 100 lm LED light output
- Variable speed trigger for precise control
- Kit includes tool, (2) batteries and a charger

Colors Available



2 Batteries, 1 Charger: K2 GK2 HVK2
 Tool Only: DB GDB HVDB
 ADD SUFFIX TO STOCK NUMBER FOR SPECIAL COLORS.

CT9080 Series Impacts

Specifications	CT9080K2
Battery Type	Lithium 5.0 Ah
Battery Voltage	18
Charge Time, minutes	90
Square Drive, inches (mm)	1/2 (13)
Torque Output, ft-lb (N•m)	1,050 (1,423)
Blows Per Minute, BPM	2,300
Free Speed, RPM	1,570
Height with Battery, inches (mm)	9.5 (241)
Length, inches (mm)	9.6 (244)
Weight, lb (kg)	8.2 (3.7)
Warranty (battery)	2 Years/1,000 Cycles
Warranty (tool and charger)	2 Years
Battery (qty)	CTB185 (2)
Battery Charger	CTC131
Optional Protective Boot	CT9075BOOT
Tool Body Only	CT9080DB

CE - DE, ES, FR, IT, GB, NL, JP

CT9080K2 18 V 1/2" Drive MonsterLithium Cordless Impact Wrench Kit

- 1,050 ft-lb (1,423 N•m) of torque output
- 1,440 ft-lb (1,952 N•m) of bolt breakaway output
- Three torque settings adapt to various applications
- Cerakote premium nose resists abrasion
- Brushless motor for longer runtime and durability
- Super bright 100 lm LED light output
- Variable speed trigger for precise control
- Kit includes tool, (2) batteries and a charger

Colors Available



2 Batteries, 1 Charger: K2 GK2 HVK2
 Tool Only: DB GDB HVDB
 Boot: GBOOT HVBOOT
 ADD SUFFIX TO STOCK NUMBER FOR SPECIAL COLORS.



CT9010K2



CT9015K2

CT9010 Series 3/8" Drive Brushless Impacts

Specifications	CT9010K2
Battery Type	Lithium 5.0 Ah
Battery Voltage	18
Charge Time, minutes	90
Square Drive, inches (mm)	3/8 (10)
Anvil Type	Friction Ring
Torque Output, ft-lb (N•m)	240 (325)
Blows Per Minute, BPM	3,520
Free Speed, RPM	1,760
Sound Power Level, dB(A)	108
Sound Pressure Level, dB(A)	97
Vibration Level, m/s ²	8.6
Length, inches (mm)	6.7 (170)
Height w/Battery, inches (mm)	10 (254)
Weight w/Battery, lb (kg)	4.9 (2.22)
Warranty (battery)	2 Years/1,000 Cycles
Warranty (tool and charger)	2 Years
Battery (qty)	CTB185 (2)
Battery Charger	CTC131
Pinned Anvil Version	CT9010P
Quick-Change Chuck Version (hex size of chuck)	CT9010QC
Tool Body Only	CT9010DB
Optional Protective Boot	CT9010BOOT

€ - DE, ES, GB, FR, IT, NL, UL, CUL

CT9010K2 18 V 3/8" Drive MonsterLithium Cordless Impact Wrench Kit

- 240 ft-lb (325 N•m) of torque output
- 325 ft-lb (441 N•m) of bolt breakaway torque
- Three torque settings adapt to various applications
- Cerakote premium nose resists abrasion
- Brushless motor for longer runtime and durability
- Super bright 100 lm LED light output
- Variable speed trigger for precise control
- Kit includes tool, (2) batteries and a charger

Colors Available



Red Green Hi-Viz

2 batteries, 1 Charger: K2 GK2 HVK2
Tool Only: DB GDB HVDB
Boot: GBOOT HVBOOT

ADD SUFFIX TO STOCK NUMBER FOR SPECIAL COLORS.

CT9015 Series 1/2" Drive Brushless Impacts

Specifications	CT9015K2
Battery Type	Lithium 5.0 Ah
Battery Voltage	18
Charge Time, minutes	90
Square Drive, inches (mm)	1/2 (13)
Anvil Type	Friction Ring
Torque Output, ft-lb (N•m)	240 (325)
Blows Per Minute, BPM	3,520
Free Speed, RPM	1,760
Sound Power Level, dB(A)	108
Sound Pressure Level, dB(A)	97
Vibration Level, m/s ²	8.6
Length, inches (mm)	6.7 (170)
Height with Battery, inches (mm)	10 (254)
Weight w/Battery, lb (kg)	4.9 (2.22)
Warranty (battery)	2 Years/1,000 Cycles
Warranty (tool and charger)	2 Years
Battery (qty)	CTB185 (2)
Battery Charger	CTC131
Tool Body Only	CT9015DB
Optional Protective Boot	CT9010BOOT

€ - DE, ES, FR, IT, GB, NL, JP

CT9015K2 18 V 1/2" Drive MonsterLithium Cordless Impact Wrench Kit

- 240 ft-lb of torque output breaks loose stubborn fasteners
- Digital microprocessor-controlled switch maximizes performance, run time and durability
- Three torque settings in forward and three in reverse to adapt to various applications
- Built-in brake prevents tool from throwing fasteners and sockets
- Super bright 100 lm LED light output
- Kit includes tool, (2) batteries and a charger

Colors Available



Red Green Hi-Viz

2 Batteries, 1 Charger: K2 GK2 HVK2
Tool Only: DB GDB HVDB
Boot: GBOOT HVBOOT

ADD SUFFIX TO STOCK NUMBER FOR SPECIAL COLORS.



- Use only impact sockets and accessories with impact wrenches
- Read Safety Precautions on pages W1-W4

CORDLESS: 18-VOLT PLATFORMS



CT9050K2



CDR9050K2

CT9050 Series 1/2" Drive Impacts

Specifications	CT9050K2
Battery Type	Lithium 5.0 Ah
Battery Voltage	18
Charge Time, minutes	90
Square Drive, inches (mm)	1/2 (13)
Anvil Type	Friction Ring
Torque Output, ft-lb (N•m)	800 (1,085)
Blows Per Minute, BPM	2,300
Free Speed, RPM	2,000
Length, inches (mm)	8.2 (208)
Height with Battery, inches (mm)	9.5 (241)
Weight with Battery, lb (kg)	6.5 (2.9)
Warranty (battery)	2 Years/1,000 Cycles
Warranty (tool and charger)	2 Years
Battery (qty)	CTB185 (2)
Battery Charger	CTC131 (1)
Pinned Anvil Version	CT9050P
Tool Only	CT9050DB
Optional Protective Boot	CT9050BOOT

CE – DE, ES, FR, IT, GB, NL, JP

CT9050K2 18 V 1/2" Drive MonsterLithium Cordless Impact Wrench Kit

- 800 ft-lb (1,085 N•m) of torque output
- 1,000 ft-lb (1,355 N•m) of bolt breakaway torque
- Three torque settings adapt to various applications
- Cerakote premium nose resists abrasion
- Brushless motor for longer runtime and durability
- Super bright 100 lm LED light output
- Variable speed trigger for precise control
- Kit includes tool, (2) batteries and a charger

Colors Available



Red Green Hi-Viz

2 Batteries, 1 Charger:	K2	GK2	HVK2
Tool Only:	DB	GDB	HVDB
Boot:	GBOOT HVBOOT		

ADD SUFFIX TO STOCK NUMBER FOR SPECIAL COLORS.

CDR9050 Series 3/8" Drive Hammer Drills

Specifications	CDR9050K2
Battery Type	Lithium 5.0 Ah
Battery Voltage	18
Charge Time, minutes	90
Chuck Capacity, inches (mm)	1/2 (13)
Spindle Thread, inches	1/2"-20 UNF
Torque Output in-lb (N•m)	470 (53.1)
RPM (high)	2,000
RPM (low)	420
Clutch Settings	23
Gear Box Type	2-Speed
Length, inches (mm)	8.1 (205)
Height, inches (mm)	10.25 (260)
Weight with Battery, lb (kg)	5.1 (2.3)
Warranty (battery)	2 Years
Warranty (tool and charger)	2 Years
Battery (qty)	CTB185 (2)
Battery Charger	CTC131
Tool Only	CDR9050DB

CDR9050K2 18 V 1/2" MonsterLithium Cordless Hammer Drill Kit

- 470 in-lb (53 N•m) of torque output
- Two-speed gear box (420/2,000) RPM
- Keyless 1/2" single sleeve metal chuck
- Drill, hammer, screw mode with 23 clutch settings
- Brushless motor for longer runtime and durability
- Variable speed trigger for precise tool control
- Super bright LED light output
- Kit includes tool, (2) batteries and a charger

Colors Available



Red Green Hi-Viz

2 Batteries, 1 Charger:	K2	GK2	HVK2
Tool Only:	DB	GDB	HVDB
Boot:	GBOOT HVBOOT		

ADD SUFFIX TO STOCK NUMBER FOR SPECIAL COLORS.



CDR9015K2



CGG8850AK1

CDR9015 1/2" Drive Drills/Drivers

Specifications	CDR9015K2
Battery Type	Lithium 5.0 Ah
Battery Voltage	18
Charge Time, minutes	90
Chuck Capacity, inches (mm)	1/2 (13)
Spindle Thread, inches	1/2"-20 UNF
Torque Output in-lb (N•m)	470 (53.1)
RPM (high)	2,000
RPM (low)	420
Clutch Settings	18 Plus Drill
Gear Box Type	2-Speed
Length, inches (mm)	7.6 (193)
Height, inches (mm)	10.25 (260)
Weight with Battery, lb (kg)	5 (2.27)
Warranty (battery)	2 Years
Warranty (tool and charger)	2 Years
Battery (qty)	CTB185 (2)
Battery Charger	CTC131
Tool Only	CDR9015DB

CE — DE, ES, GB, FR, IT, NL, UL, CUL

CDR9015K2 18 V 1/2" MonsterLithium Cordless Drill Kit

- 470 in-lb (53 N•m) of torque output
- Two-speed gear box (420/2,000) RPM
- Keyless 1/2" metal single sleeve keyless chuck
- Drill plus 18 clutch settings adjust for the application
- Brushless motor for longer runtime and durability
- Variable speed trigger for precise tool control
- Super bright LED light output
- Kit includes tool, (2) batteries and a charger

Colors Available



2 Batteries, 1 Charger:	K2	GK2	HVK2
Tool Only:	DB	GDB	HVDB
Boot:	GBOOT HVBOOT		

ADD SUFFIX TO STOCK NUMBER FOR SPECIAL COLORS.

CGG8850A Grease Guns

Specifications	CGG8850AK1
Battery Type	Lithium 5.0 Ah
Battery Voltage	18
Charge Time, minutes	90
Pressure Rating, PSI	3,000 High Output/ 7,500 Low Output
Pressure Rating, BAR	206 High Output/517 Low Output
Capacity, Tubes Per Charge	Up to 27 (free flow)/ Up to 17 (@1,000 PSI)
Maximum Tube Capacity	14-1/2 oz (411 g) Cartridge/ 16 oz (454 g) Bulk
Handle Material	Glass-Reinforced Nylon
Coupler Design	3-Jaw
Hose Length, inches (mm)	36 (914)
Hose Type	High Pressure with Protective Spring Guards
Bulk Filler Valve	Yes
Air Purge Valve	Yes
Height with Grease Tube, inches (mm)	19 (483)
Weight with Battery Pack, lb (kg)	7.9 (3.6)
Weight without Battery Pack, lb (kg)	6.4 (2.9)
Warranty (battery)	2 Years
Warranty (tool)	2 Years
Battery (qty)	CTB185 (1)
Battery Charger	CTC131
Tool Only	CGG8850ADB

CGG8850AK1 18 V MonsterLithium Cordless Grease Gun Kit (One Battery/Charger)

- Two-speed, high-torque 18 V DC motor delivers outstanding flow and pressure
- 36" high-pressure hose with spring guard and coupler
- Accessible check valve and combination air bleeder/filler valve
- Dual motor protection includes self-resetting thermo-coupler
- Machined and hardened piston with plated steel barrel and premium grease follower
- Ergonomically designed to reduce fatigue and increase productivity
- 18 V high-amperage lithium ion battery provides outstanding run time
- Works well in cold environments
- Kit includes tool, (1) battery and a charger

Colors Available



1 Battery, 1 Charger:	K1	GK1	HVK1
Tool Only:	DB	GDB	HVDB

ADD SUFFIX TO STOCK NUMBER FOR SPECIAL COLORS.



- Use only impact sockets and accessories with impact wrenches
- Read Safety Precautions on pages W1-W4

CORDLESS: 18-VOLT PLATFORMS



CTCG8850K1



CTRS8850AK1

CTCG8850 Series Caulk Guns

Specifications	CTCG8850K1
Battery Type	Lithium 5.0 Ah
Battery Voltage	18
Charge Time, minutes	90
Feed Speed Rate, inches per minute	2–18
Vibration Level	.5 m/s ²
Sound Pressure Level (A), dB	56.8
Maximum Current	5 A
Maximum Feed Force, lbf	850
Weight w/Battery, lb (kg)	5.3 (2.4)
Warranty (tool and charger)	2 Years
Warranty (battery)	2 Years/1,000 Cycles
Battery (qty)	CTB185 (1)
Battery Charger	CTC131
Tool Body Only	CTCG8850DB

CTCG8850K1 18 V MonsterLithium Cordless Caulk Gun Kit

- High feed force to easily dispense material, even when cold
- Dispense rates from 2–18 inch/minute allows user to fine tune material dispensing
- Piston retracts automatically when trigger is released to stop material from dispensing—saves time and material
- Dispenses up to 400 tubes of caulk on a single charge
- Light weight for easy maneuverability
- Very low noise level and vibration reduces user fatigue
- Easily changes from one tube style to another to get the job done quickly
- 10 oz cartridge (included), optional kits available for 29 oz cartridge kit and 600 ml sausage kit

Colors Available



Red Green Hi-Viz

1 Battery, 1 Charger: K1 GK1 HVK1

Tool Only: DB GDB HVDB

ADD SUFFIX TO STOCK NUMBER FOR SPECIAL COLORS.

CTRS8850 Series Reciprocating Saw

Specifications	CTRS8850AK1
Battery Type	Lithium 5.0 Ah
Battery Voltage	18
Charge Time, minutes	90
Stroke Length, inches (mm)	1 (25.4)
Strokes Per Minute	2,400
Height with Battery, inches (mm)	8.25 (210)
Length, inches (mm)	18 (457)
Weight with Battery Pack, lb (kg)	7.7 (3.4)
Warranty (tool and charger)	2 Years
Warranty (battery)	2 Years/1,000 Cycles
Battery (qty)	CTB185 (1)
Battery Charger	CTC131
Tool Only	CTRS8850ADB

CTRS8850AK1 18 V MonsterLithium Cordless Reciprocating Saw Kit (One Battery/Charger)

- 2,400 strokes per minute
- 75 A rated, heavy-duty variable-speed trigger provides long life and is contoured to reduce user fatigue
- Heavy-duty 14-gauge internal wiring withstands high current loads during heavy sawing
- Spring-loaded blade retention system requires no tools and ejects broken blades easily
- Non-slip cushion grip nose reduces vibration and provides positive tool control
- Heavy-duty armature and balanced motor design for smooth operation
- Turbine-style cooling system reduces heat buildup, extending tool life
- Sealed nose mechanism prevents dirt and sawing debris from damaging internal components
- Kit includes tool, (1) battery and a charger

Colors Available



Red Green Hi-Viz

1 Battery, 1 Charger: K1 GK1 HVK1

Tool Only: DB GDB HVDB

ADD SUFFIX TO STOCK NUMBER FOR SPECIAL COLORS.



CTGR8845AK1



CTGR8855AK1



CTGR8850AK1

Grinders/Cut-Off Tools

Specifications	CTGR8845AK1	CTGR8855AK1	CTGR8850AK1
Battery Type	Lithium 5.0 Ah	Lithium 5.0 Ah	Lithium 5.0 Ah
Battery Voltage	18	18	18
Charge Time, minutes	90	90	90
Wheel Size, inches (mm)	4.5 (114) or 5 (127)	4.5 (114) or 5 (127)	4.5 (114) or 5 (127)
Arbor Size, inches (mm)	7/8 (22)	7/8 (22)	7/8 (22)
Free Speed, RPM	8,000	8,000	8,000
Spindle Thread, inches	5/8"-11	5/8"-11	5/8"-11
Length w/battery, inches (mm)	16 (406)	16.5 (419)	16.5 (419)
Weight with Battery, lb (kg)	5.3 (2.4)	6.2 (2.8)	6.2 (2.8)
Switch Type	Paddle Switch	Safety Switch	Slide Switch
Warranty (tool and charger)	2 Years	2 Years	2 Years
Warranty (battery)	2 Years/1,000 Cycles	2 Years/1,000 Cycles	2 Years/1,000 Cycles
Replacement Grinding Wheel (size)	PT450-WH (4.5")	PT450-WH (4.5")	PT450-WH (4.5")
Replacement Cut-Off Wheel	CTGR-CW50	CTGR-CW50	CTGR-CW50
Battery (qty)	CTB185 (1)	CTB185 (1)	CTB185 (1)
Battery Charger	CTC131 (1)	CTC131 (1)	CTC131 (1)
Tool Only	CTGR8845ADB	CTGR8855ADB	CTGR8850ADB

UL® listed.
 CE - DE, ES, FR, IT, GB, NL, JP

CTGR8845AK1 18 V 4-1/2" MonsterLithium Cordless Standard Grinder Kit (One Battery/Charger)

- Standard head for use with 4-1/2" and 5" wheels
- Features a tool-free arbor nut for fast wheel changes
- Powerful motor delivers 8,000 RPM
- Includes removable cutting wheel guard for flexibility
- Electronic brake for enhanced user safety
- Motor screen helps keep debris out of the motor
- Battery rotates 270° for improved access
- Anti-vibration handle for less fatigue
- Paddle-style switch for OSHA® compliance
- Kit includes tool, (1) battery and a charger

CTGR8850AK1 18 V MonsterLithium Cordless Angle Grinder/Cut-Off Tool Kit (One Battery/Charger)

- 8,000 RPM handles most grinding jobs with ease
- Ultra-slim head allows user to access areas other grinders cannot
- Battery rotates 270° for improved access
- Accepts 4-1/2" or 5" wheels for more options to quickly get the job done
- Anti-vibration handle—allows user to work longer and more comfortably
- Replaceable motor screen—keeps debris out of the motor so tool lasts longer
- Seven-position safety guard—lets user tackle most jobs with less effort
- Tool-free guard removal—simply pull one guard off and slide the other one on
- Kit includes tool, (1) battery and a charger

CTGR8855AK1 18 V MonsterLithium Angle Grinder/Cut-Off Tool Kit with Safety Switch (One Battery/Charger)

- Flat head design for easy access
- 8,000 RPM handles most grinding jobs with ease
- Use with 4-1/2" or 5" wheels—more options to get the job done fast
- Seven-position safety guard
- Electronic safety clutch
- Motor screen keeps debris out of the motor to extend tool life
- Battery rotates 270° for improved access
- Anti-vibration handle—allows user to work longer and more comfortably
- High-stall torque
- OSHA® compliant switch
- Kit includes tool, (1) battery and a charger

CTGR-CW50 5" Abrasive Cutting Wheel

- Replacement cutting wheel for CTGR8850 cordless grinder

CTGR-CW50MP 5" Abrasive Cutting Wheel (25 pack)

- Replacement cutting wheel for CTGR8850 cordless grinder



• Use only impact sockets and accessories with impact wrenches
 • Read Safety Precautions on pages W1-W4

CORDLESS: 18-VOLT PLATFORMS



CTGRS8806AK1



CTGRS8825AK1

Die Grinders

Specifications	CTGRS8806AK1	CTGRS8825AK1
Battery Type	Lithium 5.0 Ah	Lithium 5.0 Ah
Battery Voltage	18	18
Charge Time, minutes	90	90
Collet Size, inches (mm)	1/4 (6)	1/4 (6)
Free Speed, RPM	6,000	25,000
Sound Pressure Level, dB(A)	81.6	80.5
Switch Type	Paddle Switch	Paddle Switch
Uncertainty K, dBA	3	3
Uncertainty, K (Vibration), m/s ²	1.5	1.5
Vibration Level, m/s ²	1.9	6.5
Height with Battery, inches (mm)	4 (102)	4 (102)
Width with Battery, inches (mm)	3 (76)	3 (76)
Weight with Battery, lb (kg)	4.9 (2.2)	4.6 (2.1)
Weight, lb (kg)	3.2 (1.5)	3.1 (1.4)
Warranty (battery)	2 Years	2 Years
Warranty (tool and charger)	2 Years	2 Years
Battery (qty)	CTB185 (1)	CTB185 (1)
Battery Charger	CTC131 (1)	CTC131 (1)
Tool Only	CTGRS8806ADB	CTGRS8825ADB

CE - DE, ES, FR, IT, GB, NL, JP

CTGRS8806AK1 18 V MonsterLithium Cordless Inline Die Grinder Kit (One Battery/Charger)

- 6,000 RPM to handle the big jobs
- Spindle lock for easy changing of accessories
- Tight tolerance collet for exact concentricity
- Overload protection prevents tool from over-heating
- Start-up protection prevents tool from starting after battery change
- Ergonomic design for positive tool control
- Standard 1/4" collet accepts most accessories
- Battery rotates 270° to adjust to each application
- Paddle style trigger for ease-of-use
- Kit includes tool, (1) battery and a charger

CTGRS8825AK1 18 V MonsterLithium Cordless Inline Die Grinder Kit (One Battery/Charger)

- 25,000 RPM handles the big jobs
- Spindle lock for easy changing of accessories
- Tight-tolerance collet for exact concentricity
- Overload protection prevents tool from overheating
- Start-up protection prevents tool from starting after battery change
- Ergonomic design for positive tool control
- Standard 1/4" collet accepts most accessories
- Battery rotates 270° for improved access
- Paddle-style trigger for ease of use
- Kit includes tool, (1) battery and a charger



CTBF8818K1

Cordless Sanders

Specifications	CTBF8818K1
Battery Type	Lithium 5.0 Ah
Battery Voltage	18
Charge Time, minutes	90
Belt Length, inches (mm)	18 (457)
Usable Belt Length, inches (mm)	3-9/16 (90)
Belt Speed, RPM	8,000
Belt widths, inches (mm)	1/4-1/2 (6-12)
Maximum Torque, in-lb	14
Length w/battery, inches (mm)	16.5 (419)
Switch Type	Safety Switch
Spindle Thread, inches	5/8"-11
Weight with Battery, lb (kg)	5.5 (2.5)
Warranty (battery)	2 Years
Warranty (tool and charger)	2 Years
Battery (qty)	CTB185 (1)
Battery Charger	CTC131
Tool Body Only	CTBF8818DB

CE - DE, ES, FR, IT, GB, NL, JP

CTBF8818K1 18 V 18" MonsterLithium Cordless Band File Sander (One Battery/Charger)

- For grinding, burnishing and deburring in hard-to-access areas
- Head can be rotated 270° for flexibility
- Features a tool-free adjustable belt guide and cover for easy belt changes
- Includes 1/4-1/2" contour sanding arm—other arms sold separately
- Accepts 18" belt and has a workable surface of 3-9/16" to help get the job done quickly
- Motor screen helps keep debris out of the motor
- Battery can be rotated 270° without tools to adjust to any working position
- Anti-vibration handle helps reduce fatigue
- Detachable dust filter protects motor from coarse particles
- OSHA®-compliant switch for added safety
- Kit includes tool, (1) battery, (1) charger and a starter kit of belts

CTBFSA12 Band File Sanding Arm, 1/2"

CTBFSA14 Band File Sanding Arm, 1/4"

CTBFSA34 Band File Sanding Arm, 3/4"

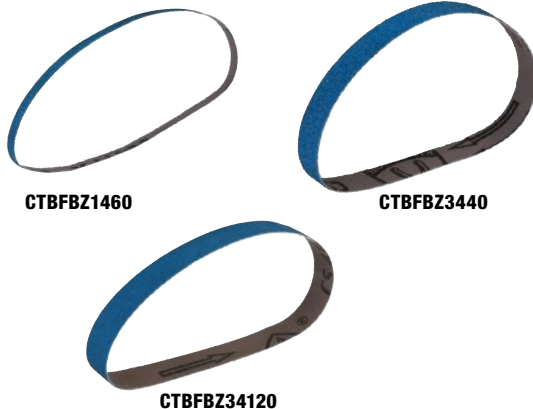

CTBFBZ1460

CTBFBZ3440

CTBFBZ34120



CTRG9050K1

Rivet Guns

Specifications	CTRG9050K1
Battery Type	Lithium 5.0 Ah
Battery Voltage	18
Charge Time, minutes	90
Pull Force, lb (kg)	4,400 (1,996)
Stroke Length, inches (mm)	.985 (25)
LED Light	3 Bulb
Height, inches (mm)	8.8 (225)
Weight, lb (kg)	5.8 (2.6)
Warranty (battery)	2 Years/1,000 Cycles
Warranty (tool and charger)	2 Years
Battery (qty)	CTB185 (1)
Battery Charger	CTC131
Tool Body Only	CTRG9050DB

CE - DE, ES, FR, IT, GB, NL, JP

CTRG9050K1 18 V MonsterLithium Brushless Rivet Gun Kit (One Battery/Charger)

- Brushless motor means superior durability, longer tool life and maximum run time
- 4,400 lb of pull force for precise accuracy
- LED light illuminates the work area
- Field replaceable long life jaws
- On board nose piece storage
- Heavy-duty tool hook allows for hanging
- Produces over 6,000 rivets on a battery charge to get the work done
- Operates with 1/8, 5/32, 3/16 and 1/4" rivets
- Kit includes tool, (1) battery and charger

Sanding Belts

Stock No.	Description
CTBFBC1240	Ceramic, 1/2 x 1/8-3/4", 40 grit (10 pk)
CTBFBC1260	Ceramic, 1/2 x 1/8-3/4", 60 grit (10 pk)
CTBFBC1280	Ceramic, 1/2 x 1/8-3/4", 80 grit (10 pk)
CTBFBC12120	Ceramic, 1/2 x 1/8-3/4", 120 grit (10 pk)
CTBFCA1412	Band File Contour Arm, 1/4-1/2
CTBFFB12COR	Fleeceband, 1/2 x 18-3/4", Coarse (5 pk)
CTBFFB12FNE	Fleeceband, 1/2 x 18-3/4", Fine (5 pk)
CTBFFBF12MED	Fleeceband, 1/2 x 18-3/4" Medium (5 pk)
CTBFFB14COR	Fleeceband, 1/4 x 18-3/4", Coarse (5 pk)
CTBFFB14FNE	Fleeceband, 1/4 x 18-3/4", Fine (5 pk)
CTBFFB14MED	Fleeceband, 1/4 x 18-3/4", Medium (5 pk)
CTBFFB34COR	Fleeceband, 3/4 x 18-3/4", Coarse (5 pk)
CTBFFB34FNE	Fleeceband, 3/4 x 18-3/4", Fine (5 pk)
CTBFFBF34MED	Fleeceband, 3/4 x 18-3/4" Medium (5 pk)
CTBFBZ1240	Zirconia, 1/2 x 18-3/4", 40 grit (10 pk)
CTBFBZ1260	Zirconia, 1/2 x 18-3/4", 60 grit (10 pk)
CTBFBZ1280	Zirconia, 1/2 x 18-3/4", 80 grit (10 pk)
CTBFBZ12120	Zirconia, 1/2 x 18-3/4", 120 grit (10 pk)
CTBFBZ1440	Zirconia, 1/4 x 18-3/4", 40 grit (10 pk)
CTBFBZ1460	Zirconia, 1/4 x 18-3/4", 60 grit (10 pk)
CTBFBZ1480	Zirconia, 1/4 x 18-3/4", 80 grit (10 pk)
CTBFBZ14120	Zirconia, 1/4 x 18-3/4", 120 grit (10 pk)
CTBFBZ3440	Zirconia, 3/4 x 18-3/4", 40 grit (10 pk)
CTBFBZ3460	Zirconia, 3/4 x 18-3/4", 60 grit (10 pk)
CTBFBZ3480	Zirconia, 3/4 x 18-3/4", 80 grit (10 pk)
CTBFBZ34120	Zirconia, 3/4 x 18-3/4", 120 grit (10 pk)



- Do not use sanding discs or accessories above their maximum rated RPM.
- Use only impact sockets and accessories with impact wrenches
- Read Safety Precautions on pages W1-W4

CORDLESS: 14.4-VOLT MICROLITHIUM PLATFORMS



CT825K2



CT861K2

CT825 Series Brushless Impact Wrenches

Specifications	CT825K2	CT861K2
Battery Type	Lithium 2.5 Ah	Lithium 2.5 Ah
Battery Voltage	14.4	14.4
Charge Time, minutes	70	70
Square Drive, inches (mm)	1/4 (6)	3/8 (10)
Anvil Type	Friction Ring	Friction Ring
Torque Output, ft-lb (N•m)	70 (95)	150 (203)
Bolt Breakaway Torque, ft-lb (N•m)	100 (135)	225 (305)
Blows Per Minute, BPM	3,000	3,000
Free Speed, RPM	2,200	2,500
No Load Current	3.0 A	3.0 A
Length, inches (mm)	6.8 (173)	6.8 (173)
Width, inches (mm)	2 (51)	2 (51)
Height, inches (mm)	7 (178)	7 (178)
Height with Battery, inches (mm)	8.0 (203)	8.0 (203)
Weight with Battery, lb (kg)	2.7 (1.2)	2.7 (1.2)
Warranty (battery)	1 Year	1 Year
Warranty (tool and charger)	1 Year	1 Year
Quick-Change Chuck Version (hex size of chuck)	—	CTQ861 (1/4")
Battery (qty)	CTB8174 (2)	CTB8174 (2)
Battery Charger	CTC772A	CTC772A
Tool Only	CT825DB	CT861DB

CE - DE, ES, FR, IT, GB, NL, JP

CT825K2 14.4 V 1/4" Drive Brushless MicroLithium Cordless Impact Wrench Kit

- 70 ft-lb of torque output handles many common fasteners
- Variable speed standard style trigger for precise control
- Tri-beam headlights illuminate the work area
- Built in brake prevents the tool from throwing fasteners and sockets
- Over current and thermal protection of the motor prevents tool from overheating
- Under voltage protection will not overdraw the battery
- Built in fuel gauge indicates battery state of charge
- Cushion grip handle provides positive tool control with less user fatigue
- Glass filled nylon housing is durable and prevents breaking
- Brushless motor means superior durability, longer tool life and maximum run time
- 70 minute charge time
- Kit includes tool, (2) batteries and a charger

Colors Available



2 Batteries, 1 Charger: **K2** **GK2** **HVK2**
 Tool Only: **DB** **GDB** **HVDB**

ADD SUFFIX TO STOCK NUMBER FOR SPECIAL COLORS.

CT861K2 14.4 V 3/8" Drive MicroLithium Cordless Impact Wrench Kit

- 150 ft-lb (203 N•m) of torque output
- 225 ft-lb (305 N•m) of bolt breakaway torque
- Tri-beam LED headlights illuminates work area
- Brushless motor for longer runtime and durability
- Variable speed trigger for precise tool control
- Glass filled nylon housing for durability
- Built in fuel gauge indicates battery state of charge
- Kit includes tool, (2) batteries and a charger

Colors Available



2 Batteries, 1 Charger: **K2** **GK2** **HVK2**
 Tool Only: **DB** **GDB** **HVDB**

ADD SUFFIX TO STOCK NUMBER FOR SPECIAL COLORS.



CDR861K2

CDR861 Series 3/8" Capacity Brushless Drills

Specifications	CDR861K2
Battery Type	Lithium 2.5 Ah
Battery Voltage	14.4
Charge Time, minutes	70
Chuck Capacity inches (mm)	3/8 (10)
Clutch Settings	9
Gear Box Type	2-Speed
Torque Output in-lb (N•m)	200 (22.6)
Free Speed, RPM, Low (High)	0-450 (0-1,550)
Sound Pressure Level, dB(A)	73.7
Length, inches (mm)	7.7 (198)
Height inches (mm)	7.8 (198)
Width, inches (mm)	2 (50)
Operating Temperature	-4-120 °F (-20-60 °C)
RPM (low)	0-450
RPM (high)	0-1,550
Weight with Battery, lb (kg)	2.4 (1.1)
Warranty (battery)	1 Year
Warranty (tool and charger)	1 Year
Battery (qty)	CTB8174 (2)
Battery Charger	CTC772A
Tool Only	CDR861DB

UL® listed.
 CE - DE, ES, FR, IT, GB, NL, JP

CDR861K2 14.4 V 3/8" MicroLithium Cordless Drill Kit

- 200 in-lb (22.6 N•m) of torque output
- Two-speed gearbox (450/1,550) RPM
- Keyless 3/8" single sleeve steel chuck
- Nine position clutch to adjust for the application
- Brushless motor for longer runtime and durability
- Variable speed trigger for precise tool control
- Built in fuel gauge indicates battery state of charge
- Kit includes tool, (2) batteries and a charger

Colors Available



2 Batteries, 1 Charger:	K2	GK2	HVK2
Tool Only:	DB	GDB	HVDB

ADD SUFFIX TO STOCK NUMBER FOR SPECIAL COLORS.



- Use only impact sockets and accessories with impact wrenches
- Read Safety Precautions on pages W1-W4

CORDLESS: 14.4-VOLT MICROLITHIUM PLATFORMS



CDRR761K2

CDRR761 Series 3/8" Capacity Right-Angle Drills

Specifications	CDRR761K2
Battery Type	Lithium 2.5 Ah
Battery Voltage	14.4
Charge Time, minutes	70
Chuck Cap., inches (mm)	3/8 (10)
Clutch Settings	9
Gear Box Type	2-Speed
Torque Output, in-lb (N•m)	150 (16.9)
Free Speed (RPM), Low (High)	0-450 (0-1,550)
Sound Pressure Level, dB(A)	73.7
Sound Power Level, dB(A)	85.3
Length, inches (mm)	13.3 (338)
Height, inches (mm)	4 (102)
Width, inches (mm)	2 (50)
Weight with Battery, lb (kg)	3.3 (1.5)
Operating Temperature Range	-4-120 °F (-20-60 °C)
RPM (low)	0-450
RPM (high)	0-1,550
Warranty (battery)	1 Year
Warranty (tool and charger)	1 Year
Battery (qty)	CTB8174 (2)
Battery Charger	CTC772A
Tool Only	CDRR761DB

CDRR761K2 14.4 V 3/8" MicroLithium Cordless Right Angle Screw Gun/Drill Kit

- 150 in-lb of torque output handles a wide variety of applications
- Two-speed drill: 400/1,550 RPM; low speed for higher torque applications, high speed for drilling steel
- Nine-position clutch delivers 8-50 in-lb of torque
- Variable-speed switch—good featherability at low speed for driving screws
- Lightweight drill—only 3.2 lb with battery
- 3/8" keyless single-sleeve durable steel chuck makes changing bits easy
- Cushion grip handle provides comfortable non-slip control for less fatigue over time
- Small size to get into tight spots—under dash, firewall, etc.
- One-year full warranty and serviced by Snap-on® Service Centers
- Built-in gauge displays the battery charge state
- Integrated LED light
- Kit includes tool, (2) batteries and a charger

Colors Available



2 Batteries, 1 Charger: **K2 GK2 HVK2**
 Tool Only: **DB GDB HVDB**

ADD SUFFIX TO STOCK NUMBER FOR SPECIAL COLORS.



CDRS761K2

CDRS761 Series 3/8" Capacity Inline Drills

Specifications	CDRS761K2
Battery Type	Lithium 2.5 Ah
Battery Voltage	14.4
Charge Time, minutes	70
Chuck Capacity, inches (mm)	3/8 (10)
Clutch Settings	9
Gear Box Type	2-Speed
Torque Output, in-lb (N•m)	65 (7.3)
Free Speed, RPM	0-1,350
Sound Pressure Level, dB(A)	80.4
Sound Power Level, dB(A)	89.6
Length, inches (mm)	13.3 (338)
Height, inches (mm)	4 (102)
Width, inches (mm)	2 (50)
Weight with Battery, lb (kg)	2.6 (1.2)
Operating Temperature	-4-140 °F (-20-60 °C)
RPM (low)	0-450
RPM (high)	0-1,550
Uncertainty K, dB(A)	3.0
Vibration Level, m/s ²	1.3
Storage Temperature	-4-140 °F (-20-60 °C)
Warranty (battery)	1 Year
Warranty (tool and charger)	1 Year
Battery (qty)	CTB8174 (2)
Charger	CTC772A
Tool Only	CDRS761DB

CDRS761K2 14.4 V 3/8" MicroLithium Cordless Inline Drill Kit

- 150 in-lb of torque handles a wide variety of applications
- Two speeds (400/1,400 RPM): low speed for higher torque applications, high speed for steel drilling
- Variable-speed switch—good featherability at low speed for driving screws and control
- Nine-position clutch
- Lightweight drill—with battery only 2.4 lb
- 3/8" keyless drill chuck—single-sleeve durable steel chuck makes changing bits easy
- Cushion grip handle—non-slip, comfort for the operator, positive tool control allows the operator to work longer with less fatigue
- Small size to get in tight spots: under dash, firewall, etc.
- One-year full warranty and serviced by Snap-on® Service Centers
- Built-in gauge displays the battery charge state
- Kit includes tool, (2) batteries and a charger

Colors Available



2 Batteries, 1 Charger: **K2 GK2 HVK2**
 Tool Only: **DB GDB HVDB**

ADD SUFFIX TO STOCK NUMBER FOR SPECIAL COLORS.

CORDLESS: 14.4-VOLT MICROLITHIUM PLATFORMS



CDRR2005K2



CDRR200545K2



CDRR2005360K2

CDRR2005 Series Angle Mini Drill

Specifications	CDRR2005K2	CDRR200545K2	CDRR2005360K2
Battery Type	Lithium 2.5 Ah	Lithium 2.5 Ah	Lithium 2.5 Ah
Battery Voltage	14.4	14.4	14.4
Charge Time, minutes	70	70	70
Bit Thread Size	1/4"-28	1/4"-28	1/4"-28
Free Speed, RPM	6,000	6,000	6,000
Length Angle Head (Front to Back), inches (mm)	1.12 (28)	1 (25)	3 (76)
Sound Pressure Level, dB(A)	74.2	74.2	74.2
Height (Head Assembly), inches (mm)	4.4 (112)	4.4 (112)	4.4 (112)
Height with Battery, inches (mm)	13.1 (333)	13.1 (333)	13.1 (333)
Vibration Level, m/s ²	8.02	8.02	8.02
Width, inches (mm)	1.8 (46)	1.8 (46)	1.8 (46)
Length, inches (mm)	12 (305)	12 (305)	12 (305)
Height, inches (mm)	3.3 (84)	3.3 (84)	3.3 (84)
Weight with Battery, lb (kg)	1.4 (.64)	1.4 (.64)	1.4 (.64)
Operating Temperature Range	-4-120 °F (-20-60 °C)	-4-120 °F (-20-60 °C)	-4-120 °F (-20-60 °C)
Warranty (battery)	1 Year	1 Year	1 Year
Warranty (tool and charger)	1 Year	1 Year	1 Year
Optional 1/4" Collet	YA409-6	YA409-6	YA409-6
Battery (qty)	CTB8174 (2)	CTB8174 (2)	CTB8174 (2)
Battery Charger	CTC772A	CTC772A	CTC772A
Tool Only	CDRR2005DB	CDRR200545DB	CDRR2005360DB

CE - DE, ES, FR, IT, GB, NL, JP

CDRR2005K2 14.4 V MicroLithium Cordless Right Angle Mini Drill Kit

- Compact head for great access
- Low runout for precise drilling
- Accepts 1/4"-28 threaded bits and accessories
- Double ball bearing supported spindle shaft for durability
- Spiral beveled gears for durability and smooth operations
- 90° angle for great access
- LED light illuminates work area
- Soft grip handle for positive tool control
- Battery fuel gauge indicates battery charge state
- Kit includes tool, (2) batteries and a charger

CDRR2005360K2 14.4 V MicroLithium Cordless 360° Angle Head Mini Drill Kit

- Small compact head for greater access into places traditional pistol style drills cannot
- Low runout for precise accurate drilling
- Accepts 1/4"-28 threaded bits and accessories and standard 1/4" accessories with adaptor (not included)
- Double ball bearing supported spindle shaft for durability
- Spiral beveled gears for durability and smooth operation
- 360° angle head for great accessibility
- Built-in LED illuminates work area
- Soft grip handle for positive tool control
- Battery fuel gauge indicates the battery state of charge
- Variable speed trigger for slow start up
- Proven lower unit and head
- Kit includes tool, (2) batteries and a charger

CDRR200545K2 14.4 V MicroLithium Cordless 45° Angle Head Mini Drill Kit

- Same features as the CDRR2005360K2



- Use only impact sockets and accessories with impact wrenches
- Read Safety Precautions on pages W1-W4

CORDLESS: 14.4-VOLT MICROLITHIUM PLATFORMS



CTS861K2

CTS861 Series Screwdrivers

Specifications	CTS861K2
Style	Pistol
Battery Type	Lithium 2.5 Ah
Battery Voltage	14.4
Trigger Style	Toggle
Charge Time, minutes	70
Chuck Cap., inches (mm)	1/4 (6)
Square Drive, inches (mm)	1/4 (6) Hex
Torque Output, in-lb (N•m)	200 (22)
Clutch Settings	9
Gear Box Type	2-Speed
Free Speed, RPM	450/1,550
RPM (low)	0-450
RPM (high)	0-1,550
Length, inches (mm)	6.1 (155)
Width, inches (mm)	1.9 (48)
Weight with Battery, lb (kg)	2.1 (1.0)
Warranty (battery)	1 Year
Warranty (tool and charger)	1 Year
Battery (qty)	CTB8174 (2)
Battery Charger	CTC772A
Tool Only	CTS861DB

CE - DE, ES, FR, IT, GB, NL

CTS861K2 14.4 V 1/4" Hex MicroLithium Cordless Toggle Screwdriver Kit

- 200 in-lb of torque output
- Two-speed gearbox: 450/1,550 RPM
- Brushless motor for longer runtime and durability
- 300 in-lb manual spindle lock
- Nine-position clutch provides the ability to dial in the proper torque
- Glass-filled nylon housing for durability
- Variable-speed toggle-style trigger for precise control
- Twin-beam headlights illuminate work area
- Quick 70-minute battery charge for less down time
- Undervoltage protection will not overdraw the battery; overcurrent protection of the electronics
- Built-in gauge displays the battery charge state
- Screened motor keeps debris from entering critical components
- Cushion grip handle provides positive tool control with less fatigue
- UL® and cUL® listed
- Kit includes tool, (2) batteries and a charger

Colors Available



Red Green Hi-Viz

2 Batteries, 1 Charger: K2 GK2 HVK2
Tool Only: DB GDB HVDB

ADD SUFFIX TO STOCK NUMBER FOR SPECIAL COLORS.



CTSR761K2

CTSR761 Series Screwdrivers

Specifications	CTSR761K2
Style	Inline
Battery Type	Lithium 2.5 Ah
Battery Voltage	14.4
Trigger Style	Paddle
Charge Time, minutes	70
Chuck Cap., inches (mm)	1/4 (6)
Square Drive, inches (mm)	1/4 (6) Hex
Torque Output, in-lb (N•m)	150 (16.9)
Clutch Settings	9
Gear Box Type	2-Speed
Free Speed, RPM	450/1,550
RPM (low)	0-450
RPM (high)	0-1,550
Width, inches (mm)	2 (50.8)
Weight with Battery, lb (kg)	2.7 (1.2)
Warranty (battery)	1 Year
Warranty (tool and charger)	1 Year
Battery (qty)	CTB8174 (2)
Battery Charger	CTC772A
Tool Only	CTSR761DB

CE

CTSR761K2 14.4 V 1/4" MicroLithium Cordless Right Angle Screwdriver Kit

- Features an oversized paddle trigger and easy-access Forward/Reverse button
- 150 in-lb of torque
- 450-1,550 RPM free speed
- Ergonomic cushion grip
- Two-speed gearbox
- Variable-speed extended trigger
- Nine-position clutch
- Built-in LED light
- Rapid 70-minute charge time
- Ideal for metals, plastic, aluminum, fiberglass, exhaust, hanger work, ATVs and mud flaps
- Used for dash work, stripped fasteners and removing/installing panels
- Handles most standard-style screwdriver bits, as well as power bits
- One-handed bit insertion
- Kit includes tool, (2) batteries and a charger

Colors Available



Red Green Hi-Viz

2 Batteries, 1 Charger: K2 GK2 HVK2
Tool Only: DB GDB HVDB

ADD SUFFIX TO STOCK NUMBER FOR SPECIAL COLORS.



CTRS761AK2

CTRS761 Series Saws

Specifications	CTRS761AK2
Battery Type	Lithium 2.5 Ah
Battery Voltage	14.4
Motor Voltage (VDC)	14.4
Charge Time, minutes	70
Strokes Per Minute	3,100
Stroke Length, inches (mm)	1/2 (13)
Sound Power Level (A), dB	87.7
Sound Pressure Level (A), dB	76.1
Uncertainty, K (Cutting 4 x 4" SPF Lumber), m/s ²	2.72
Uncertainty, K (Noise), dB	3
Uncertainty, K (Vibration), m/s ²	1.54
Vibration Level (Cutting 4 x 4" SPF Lumber), m/s ²	7.41
Vibration Level, m/s ²	11.97
Variable Speed Switch	Yes
Length, inches (mm)	12 (304)
Weight with Battery Pack (Li-Ion), lb (kg)	3.2 (1.5)
Warranty (battery)	1 Year
Warranty (tool and charger)	1 Year
Battery (qty)	CTB8174 (2)
Battery Charger	CTC772A
Tool Only	CTRS761ADB

CTRS761AK2 14.4 V MicroLithium Cordless Reciprocating Saw Kit

- 3,100 strokes per minute
- Small and lightweight; ideal for use in confined areas
- Dual chuck mechanism (quick chuck)
- Tool-free adjustment of the depth guide
- Variable-speed switch
- Integrated LED work light
- LED gauge indicates battery charge state
- Six-position adjustable footplate
- Quick, one-handed blade release
- Housing screen keeps debris out of the motor
- Lock-off switch is located above the trigger
- Variable-speed trigger
- Kit includes tool, (2) batteries and a charger

Colors Available



Red Green Hi-Viz

2 Batteries, 1 Charger: K2 GK2 HVK2
Tool Only:: DB GDB HVDB

ADD SUFFIX TO STOCK NUMBER FOR SPECIAL COLORS.



CTSS761K2

CTSS761 Series Screwdrivers

Specifications	CTSS761K2
Style	Inline
Battery Type	Lithium 2.5 Ah
Battery Voltage	14.4
Trigger Style	Paddle
Charge Time, minutes	70
Chuck Cap., inches (mm)	1/4 (6)
Clutch Settings	9
Square Drive, inches (mm)	1/4 (6) Hex
Sound Power Level A, dBA	76.9
Sound Pressure Level A, dBA	65.3
Torque Output, in-lb (N•m)	65 (7.3)
Free Speed, RPM	0-1,350
Gear Box Type	Single Speed
Uncertainty K, dBA	3.0
Vibration Level, m/s ²	0.93
Vibration Uncertainty K, m/s ²	0.25
Length, inches (mm)	11.8 (300)
Width, inches (mm)	2 (50.8)
Weight with Battery, lb (kg)	2.2 (1.0)
Warranty (battery)	1 Year
Warranty (tool and charger)	1 Year
Battery (qty)	CTB8174 (2)
Battery Charger	CTC772A
Tool Only	CTSS761DB

CTSS761K2 14.4 V MicroLithium Cordless Inline Screwdriver Kit

- 65 in-lb of torque output to get the job done
- 1,350 RPM
- Variable-speed trigger allows the user to regulate the proper RPM
- Nine-position clutch to dial in the proper torque
- Built-in LED illuminates work area
- Rapid 70-minute charge time keeps the job moving
- Handles most standard style screwdriver bits as well as power bits
- One-handed bit insertion
- Cushion grip handle provides comfortable non-slip control for less fatigue over time
- Easy-access Forward/Reverse button
- Kit includes tool, (2) batteries and a charger

Colors Available



Red Green Hi-Viz

2 Batteries, 1 Charger: K2 GK2 HVK2
Tool Only: DB GDB HVDB

ADD SUFFIX TO STOCK NUMBER FOR SPECIAL COLORS.



• Read Safety Precautions on pages W1-W4

CORDLESS: 14.4-VOLT MICROLITHIUM PLATFORMS



CTR762K2



CTR861K2



CTR814K2

CTR762 Series 14.4 V Snap-on® Brute Cordless Ratchet

Specifications	CTR762K2	CTR861K2	CTR814K2
Battery Type	Lithium 2.5 Ah	Lithium 2.5 Ah	Lithium 2.5 Ah
Battery Voltage	14.4	14.4	14.4
Charge Time, minutes	70	70	70
Square Drive, inches (mm)	3/8 (10)	3/8 (10)	1/4 (6)
Torque Output, ft-lb (N•m)	70 (95)	60 (81)	35 (47)
Manual Torque, ft-lb (N•m)	158 (214)	158 (214)	46 (62)
Free Speed, RPM	175	275	350
Height with Battery, inches (mm)	12.8 (324)	12.2 (310)	11.1 (282)
Weight with Battery, lb (kg)	2.8 (1.3)	2.7 (1.2)	2 (0.9)
Warranty (battery)	1 Year	1 Year	1 Year
Warranty (tool and charger)	1 Year	1 Year	1 Year
Battery (qty)	CTB8174 (2)	CTB8174 (2)	CTB8174 (2)
Battery Charger	CTC772A	CTC772A	CTC772A
Tool Only	CTR762DB	CTR861DB	CTR814DB

CE

CTR762K2 14.4 V 3/8" Drive MicroLithium Cordless Ratchet Kit

- 70 ft-lb of torque output to get the job done
- Variable-speed trigger for precise tool control
- Integrated LED light illuminates the work area
- Cushion grip handle provides positive tool control
- Large forward/reverse knob for easy change of direction
- LED fuel gauge helps identify the battery's charge state
- 2.5 Ah batteries for extra-long run time between charges
- Kit includes tool, (2) batteries and a charger

CTR861K2 14.4 V 3/8" Drive MicroLithium Cordless Ratchet Kit

- 60 ft-lb of torque output gets the big jobs done
- 158 ft-lb of manual torque helps bust stubborn fasteners loose
- 275 RPM free speed removes fasteners rapidly
- Super bright 18 lm light stays illuminated after trigger is released
- Brushless motor means superior durability, longer tool life and maximum run time
- Auto trigger shuts tool off after two minutes of continuous use
- Variable-speed trigger allows for slow start-ups
- Cushion grip handle for positive tool control
- Built-in fuel gauge indicates battery charge
- Large greased forward/reverse knob allows for lubricating the head
- Kit includes tool, (2) batteries and a charger

CTR814K2 14.4 V 1/4" Drive MicroLithium Cordless Ratchet Kit

- Powerful 35 ft-lb of torque output, perfect for applications with fasteners 12 mm or smaller
- 350 RPM free speed removes fasteners rapidly
- Brushless motor for longer run time and durability
- Integrated LED headlight illuminates work area
- Variable speed trigger for precise tool control
- Over and under temperature protection keeps tool operating efficiently
- Cushion grip handle for positive tool control with less user fatigue
- Large greasable reversing knob for ease of direction change
- Battery gauge displays power remaining indicates battery charge state
- Includes tool, (2) batteries and charger

Colors Available



Red Green Hi-Viz

2 Batteries, 1 Charger: K2 GK2 HVK2
Tool Only: DB GDB HVDB

ADD SUFFIX TO STOCK NUMBER FOR SPECIAL COLORS.

CORDLESS: 14.4-VOLT MICROLITHIUM PLATFORMS



CTR768K2

CTR817K2

CTR867K2

CTR768 Series Long-Neck Ratchets

Specifications	CTR768K2	CTR817K2	CTR867K2
Battery Type	Lithium 2.5 Ah	Lithium 2.5 Ah	Lithium 2.5 Ah
Battery Voltage	14.4	14.4	14.4
Charge Time, minutes	70	70	70
Square Drive, inches (mm)	3/8 (10)	1/4 (6)	3/8 (10)
Torque Output, ft-lb (N•m)	70 (95)	35 (47)	60 (81)
Manual Torque, ft-lb (N•m)	158 (214)	46 (62)	158 (214)
Free Speed, RPM	175	350	275
Height with Battery, inches (mm)	16.2 (411)	13.9 (353)	15.6 (396)
Weight with Battery, lb (kg)	3.5 (1.5)	2.4 (1.1)	3.3 (1.5)
Warranty (battery)	1 Year	1 Year	1 Year
Warranty (tool and charger)	1 Year	1 Year	1 Year
Battery (qty)	CTB8174 (2)	CTB8174 (2)	CTB8174 (2)
Battery Charger	CTC772A	CTC772A	CTC772A
Tool Only	CTR768DB	CTR817DB	CTR867DB

CE - DE, ES, FR, IT, GB, NL, JP

CTR768K2 14.4 V 3/8" Drive MicroLithium Cordless Long-Neck Ratchet Kit

- 70 ft-lb of torque output to get the job done
- Variable-speed trigger for precise tool control
- Integrated LED light illuminates the work area
- Cushion grip handle provides positive tool control
- Large forward/reverse knob for easy direction change
- Battery gauge displays power remaining
- Uses 2.5 Ah battery for extra-long run time
- Long neck to access hard-to-reach fasteners
- Includes tool, (2) batteries and a charger

CTR817K2 14.4 V 1/4" Drive MicroLithium Cordless Long-Neck Ratchet Kit

- Powerful 35 ft-lb of torque output, perfect for applications with fasteners 12 mm or smaller
- 350 RPM free speed removes fasteners rapidly
- Variable-speed trigger for precise tool control
- Built in LED illuminates work area
- Long 6" extended neck for great accessibility
- Brushless motor means superior durability, longer tool life and maximum run time
- Kit includes tool, (2) batteries and a charger

CTR867K2 14.4 V 3/8" Drive MicroLithium Cordless Long-Neck Ratchet Kit

- 60 ft-lb of torque output removes stubborn fasteners
- 158 ft-lb of manual torque to loosen rusty fasteners
- 275 RPM gets the job done quickly
- Variable-speed trigger for precise control
- Over- and under-temperature protection keeps tool operating at peak efficiency
- Cushion grip handle provides comfortable non-slip control for less fatigue over time
- Large, greasable forward/reverse knob makes it easy to switch directions
- Battery gauge displays power remaining
- Integrated 18 lm LED headlight illuminates work area
- Brushless motor means superior durability, longer tool life and maximum run time
- Kit includes tool, (2) batteries and a charger

Colors Available



Red Green Hi-Viz

2 Batteries, 1 Charger: K2 GK2 HVK2

Tool Only: DB GDB HVDB

ADD SUFFIX TO STOCK NUMBER FOR SPECIAL COLORS.



• Read Safety Precautions on pages W1-W4

CORDLESS: 14.4-VOLT MICROLITHIUM PLATFORMS



CGRS861/CGRR861 Series Die Grinders

Specifications	CGRS861K2	CGRR861K2
Battery Type	Lithium 2.5 Ah	Lithium 2.5 Ah
Battery Voltage	14.4	14.4
Warranty (battery)	1 Year	1 Year
Charge Time, minutes	70	70
Warranty (tool and charger)	1 Year	1 Year
Chuck Capacity, inches (mm)	1/8 (3) and 1/4 (6)	1/8 (3) and 1/4 (6)
Weight with Battery, lb (kg)	1.7 (.77)	2.2 (0.99)
Free Speed, RPM	10,000–30,000	9,500–28,000
Length with Battery, inches (mm)	11.4 (290)	11.4 (290)
Width with Battery, inches (mm)	2 (50)	2 (50)
Height with Battery, inches (mm)	3.3 (84)	3.3 (84)
Battery (qty)	CTB8174 (2)	CTB8174 (2)
Charger	CTC772A	CTC772A
Tool Only	CGRS861DB	CGRR861DB

CE - DE, ES, FR, IT, GB, NL, JP

CGRS861K2 14.4 V MicroLithium Brushless Cordless Inline Die Grinder Kit

- Ideal for use with 2" accessories
- Small, lightweight and portable
- Dual collet system accepts 1/8" or 1/4" accessories
- Push-button spindle lock for fast bit changes
- Variable speed allows user to adjust the required torque
- Low battery light indicates when battery needs charging
- 10,000–30,000 RPM
- 1.7 lb weight and 11.4" overall length allows for easy access and maneuverability
- Kit includes tool, (2) batteries and a charger

CGRR861K2 14.4 V MicroLithium Brushless Cordless Right Angle Die Grinder Kit

- Same features as CGRS861K2
- 9,500–28,000 RPM
- 2.2 lb weight and 11.4" overall length allows for easy access and maneuverability
- Kit includes tool, (2) batteries and a charger

Colors Available



2 Batteries, 1 Charger:	K2	GK2	HVK2
Tool Only:	DB	GDB	HVDB

ADD SUFFIX TO STOCK NUMBER FOR SPECIAL COLORS.



CTG861K1

CTG861 Series Color Display Infrared Thermometers

Specifications	CTG861K1
Alarm	On/Off and High/Low
Ambient Operating Range, °F (°C)	32–120 (0–50)
Runtime on a Single Battery Charge, hours	35
Display Hold	Last reading and operating mode display for 10 sec nominal upon trigger release
Distance To Spot Size	12:1 (90% energy covered)
Emmissivity	0.30–0.99 Adjustable
IR Accuracy	0–560 °C; ±2% or 2 °C; -18–0 °C: 5 °C 560–1,000 °C ±2% ±3dig
IR Repeatability (+23 Ems=0.95)	±2% or ±2 °C/°F
IR Resolution	< 1,000 °C/°F; 0.1 °C/°F; > 1,000 °C/°F; 1 °C/°F
K Type Range (Optional)	-328–2,372 °F (-200–1,300 °C)
K Type Accuracy (Optional)	.05% of Reading ±1.8 °F (±1 °C)
Record	Rec/Max/Min
Relative Humidity	10–80% RH non-condensing
Response Time	500 mSec
Spectral Response	7–14 um
Storage Temperature	14–140 °F (-10–60 °C) without Battery
Battery (qty)	CTB8174 (1)
Battery Type	Snap-on® 14.4 Volt
Charger	CTC772A
Tool Only	CTG861DB

CE - DE, ES, FR, IT, GB, NL, JP

CTG861K1 14.4 V MicroLithium Color Display Cordless Temperature Gun Kit

- Safe non-contact and contact temp options
- Temperature range: -58–1,832 °F (-50–1,000 °C)
- Records min, max and live readings
- SATURNCIRCLE SIGHT laser pointer
- Adjustable emissivity from 0.3–1.0
- Response time 500 mSec
- Alarm On/Off and High/Low
- 35-hour continuous run-time
- High-contrast, large color LCD display with backlight
- Kit includes tool, (1) battery and a charger



CTPP861K2

CTPP861 Series Polish/Prep Tools

Specifications	CTPP861K2
Battery Type	Lithium 2.5 Ah
Battery Voltage	14.4
Charge Time, minutes	70
Spindle Thread, inches	5/16"-24 UNF
Free Speed, RPM, Low (High)	0–3,500 (0–15,000)
Height, inches (mm)	7-4/5 (198)
Length, inches (mm)	5.75 (146)
Warranty (battery)	1 Year
Warranty (tool and charger)	1 Year
Battery (qty)	CTB8174 (2)
Battery Charger	CTC772A
Tool Only	CTPP861DB

CE - DE, ES, FR, IT, GB, NL, JP

CTPP861K2 14.4 V MicroLithium Brushless Cordless Polish/Prep Tool Kit

- Two-speed gearbox: 3,500/15,000 RPM
- Digital variable-speed trigger for precise tool control
- Push-button spindle lock for ease of use with accessories
- 5/16"-24 UNF threads
- Cushion grip handle provides positive tool control
- Built-in gauge indicates battery charge state
- 2.5 Ah battery for extra long runtime between charges
- Kit includes tool, (2) batteries and a charger
- Includes various sanding accessories

CORDLESS: LIGHTS

Cordless Lights

CTLAR761 14.4 V MicroLithium 500 Lumen Cordless Angular Light (Tool Only)

- Variable brightness switch (0–100%) offers the ability to select the right amount of light for every situation
- Intelligent lighting control provides visual warning when light has less than 5% power remaining
- Built-in hook, (2) magnets and tether point provide maximum flexibility when attaching light to work site
- 4-hour run time at 100% brightness; 8 hours at 40%
- IP65 rated for water and dust resistance, allowing for exposure in even the toughest environments
- Battery gauge displays power remaining
- Ergonomic grip and pivoting light bar provide comfort and light where needed most
- Works with CTB8174 battery
- Battery and charger not included



CTLAR761



• Read Safety Precautions on pages W1–W4

CORDLESS: LIGHTS



CTLZ761

Flashlights

CTLZ761 14.4 V MicroLithium 200 Lumen Work Light with Laser (Tool Only)

- 200 lm output
- Low battery indicator (10 minutes)
- 4-hour run time
- Laser pointer
- Resists automotive fluids
- Impact-modified nylon housing
- Tempered-glass lens
- Works with CTB6172, CTB7172, CTB8172, CTB8172BK and CTB8174 batteries
- Battery and charger not included



CTLED861

CTLED861* 14.4 V MicroLithium 500 Lumen Cordless Work Light (Tool Only)

- 500 lm output
- 120° rotating head
- 13-hour run time, with 10-minute low battery indicator
- Tempered-glass lens
- Easily adjusts from spot to flood
- Aluminum head
- Resists automotive fluids
- Impact-modified glass-filled nylon housing
- High-quality LED bulb
- Works with CTB6172, CTB7172, CTB8172, CTB8172BK and CTB8174 batteries
- Battery and charger not included



CTLED9050

Flashlights

CTLED9050 18 V MonsterLithium 800 Lumen Cordless Work Light (Tool Only)

- High output light; 800 lm
- Dual reflector system easily changes from flood to beam
- 120° rotating head
- 50,000-hour bulb life
- 11-hour run time
- Tempered glass lens resists cracking and yellowing
- Resists most automotive fluids
- Low battery light indicates when battery needs charging
- High/Low switch allows user to reduce light output 50%
- Battery and charger not included

Colors Available



ADD SUFFIX TO STOCK NUMBER FOR SPECIAL COLORS.



CTLUV761

Ultraviolet Flashlights

CTLUV761 14.4 V MicroLithium UV Cordless Work Light

- Detect leaks with this 14.4 V MicroLithium cordless UV Work Light
- Compatible with standard leak detection dyes
- Inspection range of 8' or more
- More than 10 hours of run-time
- Tempered-glass lens
- Resists automotive fluids
- Low battery indicator (10 minutes)
- Works great with ACTR53625 universal dye
- Includes fluorescence-enhancing glasses



CTLUH861

Colors Available

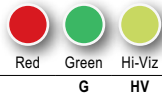

ADD SUFFIX TO STOCK NUMBER FOR SPECIAL COLORS.

Underhood Lighting

CTLUH861 14.4 V MicroLithium Cordless Underhood Light (Tool Only)

- Ultra-bright 1,000 lm output
- 4-hour run time; ideal for underhood, undercarriage and over-dash applications
- Expandable 81" clamp to position light at work area
- High-impact plastic light tube and housing
- 10-minute low battery indicator
- Includes hook with peg for hanging
- Works with CTB8172, CTB8172BK and CTB8174 batteries
- Battery and charger not included



CTLU861

Colors Available



ADD SUFFIX TO STOCK NUMBER FOR SPECIAL COLORS.

Shop Lights

CTLU861 14.4 V MicroLithium 700 Lumen Cordless Utility Light (Tool Only)

- 700 lm ultra-bright output
- 6-hour run time
- 60 LED bulbs
- 10-minute low battery indicator
- Hanging hook
- Multi-position switch
- Resists most automotive fluids
- Works with Snap-on® lithium batteries
- Ergonomic cushion grip for better control
- High-impact, replaceable light tube resists cracking and discoloration
- Battery and charger not included

CORDLESS: FLOODLIGHTS



CTL8850

Floodlights

CTL8850 18 V MonsterLithium 750 Lumen LED Cordless Floodlight (Tool Only)

- Super-bright four-LED light
- Compact design for versatile use
- Rotates 120° and swivels 180° to direct light to the work area
- Tempered-glass lens
- Dual brightness settings (750 and 375 lm)
- 8-hour minimum run time (high setting)
- Resists automotive fluids
- Battery and charger not included

Colors Available

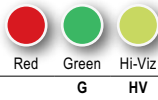

ADD SUFFIX TO STOCK NUMBER FOR SPECIAL COLORS.



CTFL9050

CTFL9050 18 V MonsterLithium 2,700 Lumen Cordless Floodlight (Tool Only)

- 18 V or 110 V dual power source
- Adjustable head allows for infinite adjustments
- Polycarbonate field-replaceable lens
- Low, medium and high settings
- 9.5 hours run time on low, 5.5 hours on medium and 2.5 hours on high
- 3.0 A USB and 2.1 A USB
- Rear-facing, red-flashing LED for roadside safety
- Large handle for easy transport
- Large front control panel for easy setting changes
- 2,700 lm output
- Sturdy wide base helps prevent tipping during use
- Rubber feet base for positive surface contact
- Battery and charger not included

CORDLESS: POWER TOOLS



CTBTSP861R

Cordless Speakers

CTBTSP861R 14.4 V MicroLithium Cordless Bluetooth® Speaker (Tool Only)

- Portable Bluetooth® connectivity up to 33' away—quality sound when and where needed
- Designed with technicians in mind, durable overmold and metal to help withstand shop environments
- Premium hi-fi sound with dual speakers for a rich quality sound experience
- Pairing feature allows an additional speaker to play simultaneously
- Harmonic distortion of .25% for crisp and clean sound
- IP54 rated resists water, automotive fluids and dust filtration
- Built-in USB output 5 V/1 A for accessory charging
- Works on Snap-on® 14.4 V battery packs
- Compatible with optional Snap-on® CTLMAGBOOT for mounting to metal surfaces
- Functions: Power, Play/Pause/USB Output, Prev/Next, Volume +/-
- Batteries and charger not included



CTBTSR9050

CTBTSR9050 18 V MonsterLithium Cordless Bluetooth® Speaker Radio (Tool Only)

- True Wireless Stereo (TWS)—pairing capable
- AM/FM radio with super tune
- Rugged structural roll cage frame design
- Powered with Snap-on® 18 V battery (not included), or 110 V AC power cord
- Two 2.1 A USB ports
- Auxiliary jack for non-Bluetooth® devices
- Integrated headphone jack
- Easy Bluetooth® pairing from up to 100' away
- Large, convenient carry handle with textured soft grip
- Easy-to-operate controls
- Incoming call feature pauses audio when call is accepted
- Power saving mode automatically puts unit in standby after five minutes of inactivity saving battery charge
- Rubber antenna prevents antenna breakage
- Batteries and charger not included



CTBTS9050

CTBTS9050 18 V MonsterLithium Cordless Bluetooth® Speaker (Tool Only)

- Powered with Snap-on® 18 V batteries or 110 V AC power cord
- Approximately 18-hour run time on fully charged 18 V battery under typical-use conditions
- Two (2) 2.1 A USB ports
- Auxiliary jack for non-Bluetooth® devices
- Integrated headphone jack
- Rugged structural roll cage-designed frame
- Easy Bluetooth® pairing up to 100'
- Large convenient carry handle with textured soft grip
- Easy-to-operate controls
- Incoming call feature pauses audio when call is accepted
- Power-saving mode automatically puts unit in standby after five minutes of inactivity, saving battery charge
- Battery and charger not included



• Read and follow safety messages in the instructions.
• Read Safety Precautions on pages W1–W4

CORDLESS: POWER TOOLS



CTFAN9050

Cordless Fans

CTFAN9050 18 V MonsterLithium Cordless Heavy-Duty Fan (Tool Only)

- 1,500 RPM air speed on low setting, 2,500 RPM on medium and 3,000 RPM on high
- Rugged, overmolded frame
- Dual power source features 18 V battery and 110 V AC charging port
- 18 V DC three-speed BLDC motor
- 13-hour battery run time on low setting, six hours on medium and four hours on high
- Indexable fan housing with (3) 6-1/2" blades
- Propeller-style blades allow for maximum airflow
- Two integrated 2.1A USB ports
- Oversized handle for easy carrying
- Large easy-to-read control panel
- Fan uses a standard extension cord; no special cords are required (cord not included)
- Batteries and charger not included



CTAB9050

Blowers

CTAB9050 18 V MonsterLithium Cordless Blower (Tool Only)

- Brushless motor means superior durability, longer tool life and maximum run time
- Get the job done with a maximum air speed of 100 MPH
- Maximum air volume of 450 CFM and 14,800 RPM for quick turnaround time
- 15' clearance range
- High/Low switch for proper air speed
- Balanced, lightweight design
- Run-time is approximately: High, 10 minutes; Low, 20 minutes
- Operates on 4.0 or 5.0 Ah batteries
- Built-in hook for easy hanging
- Batteries and charger not included



CTINF9050

Cordless Inflators

CTINF9050 18 V MonsterLithium Cordless Inflator (Tool Only)

- Features heavy-duty 30 mm high-volume piston compressor motor
- 35 L/min maximum flow
- Inflates standard auto tire (195/65R15) 0-40 PSI in less than four minutes
- Thermal shutoff protection circuit
- Auto shutoff and pressure reset
- Backlit LCD display
- 44" field-replaceable hose
- Dual rear-mounted 200 lm LED lights
- Rugged overmolded frame
- Target PSI preset feature
- Two integrated 2.1 Ah USB ports
- Assorted nozzle inflators included
- 120 PSI maximum working pressure
- Batteries and charger not included



CTVAC9050A

Cordless Vacuums

CTVAC9050A 18 V MonsterLithium Cordless Vacuum (Tool Only)

- 2.5-gal wet or dry tank eliminates the need for two specialized vacuums
- Powerful 18 V motor delivers 59 CFM of volume to handle a wide range of material
- Industry-leading suction is ideal for broken glass, rocks, coins, sand and much more
- Oversize power switch is easier to use, even with gloves
- Extra long 6' hose can double in length so it can reach further into applications
- 19" extension wand helps keep you upright
- 9" crevice tool reaches the tightest spots
- 3-1 utility nozzle is 4-1/2" wide and includes a dust brush and silicone upholstery brush for pet hair
- Onboard storage for all accessories keeps productivity up
- Shielded battery port keeps debris and moisture away from the battery
- 15 minutes of run time on a 5 Ah battery charge to get the work done
- Oversized soft grip folding handle for comfort
- Batteries and charger not included



CTVAC9050-22



CTVAC9050-25



CTVAC9050-23



CTVAC9050-24



CTVAC9050-26



CTVAC9050-27

Memory Savers/Power Inverters

CTI8850 18 V Power Inverter

- 175 W cordless inverter
- 120 V AC power
- 5 V 1 A USB output
- Overload, short circuit and battery voltage protector
- Flexible rotating head
- Protective external fuse and cooling fan
- Provides 110 V AC power anywhere

CTMS8850 18 V Cordless Memory Saver

- Provides temporary power to a vehicle to keep all presets (radio, seats, etc.) intact while the vehicle is being serviced
- Features a flexible swiveling head and protective external fuse for maximum flexibility and hassle-free use
- 4-hour run time at 12 V, 1 A; 1-hour run time at 12 V, 4 A (max output)
- 5 V, 1 A USB output
- Protective external fuse



CTI8850



CTMS8850

USB Power Units

CTUSB761 14.4 V MicroLithium USB Power Unit

- Connects to battery for 5 V, 1 A output, up to two hours
- LED power indicator
- USB protective sliding cover
- Easy On/Off switch
- Use with CTB8172 and CTB8174 batteries (not included)
- Charges cell phones and other small electronic devices

CTUSB8850 Four-Port USB Device Charger

- Adaptor for 18 V MonsterLithium Ion battery pack
- Four-Port USB charging device
- (4) 5 V Outputs: 2 A, 1 A, .5 A, .5 A
- LED indicator for charge state
- Ratcheting mountable USB head
- Eight-hour run time at 5 V/2 A with CTB8187 battery (not included)
- Handy On/Off switch



CTUSB761



CTUSB8850

EEBC12000USB Battery Pack

- Built-in flashlight
- Charge cell phone, etc. through USB ports
- Numerical battery power level display



EEBC12000USB

CORDLESS: CHARGERS AND BATTERIES



CTB185

CTB1856

CTB8174

CTB8187

Snap-on® Battery Packs

Stock No.	Type	Battery Voltage	Battery Style	Charge Time, minutes	Use with
CTB185	Lithium Ion	18 V 5.0 Ah	Slide-on	90	CT9010, CT9050, CT9080, CT9100, CTRG9050, CTCG8850, CTLED9050, CDR9015, CDR9050, CTRS8850A, CCG8850A, CTGR8845A, CTGR8850A, CTGR8855A, CTGRS8806A, CTGRS8825A, CTBF8818A
CTB1856	Lithium Ion	18 V 5.6 Ah	Slide-on	95	
CTB8174	Lithium Ion	14.4 2.5 Ah	Tower	70	Generic to All 14.4 V MicroLithium Product
CTB8187	Lithium Ion	18 V 5.0 Ah	Slide-on	90	Generic to All 18 V Lithium Product

CE-DE, ES, FR, IT, GB, NL, JP

CTB185 18 V 5 Ah MonsterLithium Battery with Dual Side Latches

- 18 V 5.0 Ah dual side latch battery
- No self discharge, will not lose charge when idle
- Four built in LED's indicate battery charge state
- No memory effect
- Glass filled nylon housing withstands drops
- 90 minute charge time
- Operates with CTC720, CTC123, CTC131 and CTC131A chargers
- Not compatible with 7850 and 8850 18 V family product

CTB1856 18 V 5.6 Ah MonsterLithium Battery

- 18 V 5.6 Ah dual side latch battery
- No self discharge, will not lose charge when idle
- Four built in LED's indicate battery charge state
- No memory effect
- Glass filled nylon housing withstands drops
- 95 minute charge time
- Operates with CTC720, CTC123, CTC131 and CTC131A chargers
- Not compatible with 7850 and 8850 18 V family product

CTB8174 14.4 V MicroLithium Battery

- 14.4 V 2.5 Ah high-capacity lithium battery (36 Wh)
- Weighs just 12 oz; fits 14.4 V and most 7.2 V 661 Series tools
- Fast 70-minute charge time
- No memory effect or self-discharge
- Glass-filled nylon housing for durability
- Operates on CTC772, CTC131, CTC131A and CTC123 chargers

CTB8187 18 V MonsterLithium Slide-On Battery

- 18 V 5.0 Ah high-capacity lithium battery (90 Wh)
- Fast 90-minute charge time
- Four-LED fuel gauge indicates battery and charger condition
- No memory effect or self-discharge
- Glass-filled nylon housing for durability
- Operates on CTC720, CTC123, CTC131 and CTC131A chargers



• Read Safety Precautions on pages W1-W4

CORDLESS: CHARGERS AND BATTERIES

Snap-on® Battery Chargers

Stock No.	Type	Application
CTC131A	14.4 and 18 V Dual Bay Charger	CTB7172, CTB8172, CTB8174, CTB7185, CTB8185, CTB8187, CTB185, CTB1856
CTC772A	7.2 V/14.4 V Lithium Charger	CTB6172, CTB7172, CTB8172 and CTB8174

Batteries not included.
 CE - DE, ES, FR, IT, GB, NL, JP



CTC131A

CTC131A 14.4 and 18 V Dual Bay Charger

- Dual bay: Charges 14.4 V MicroLithium and 18 V Lithium batteries consecutively
- Integrated USB port: Charges phones and small electronic devices
- LED fuel gauge indicator: Indicates the state of the battery charge
- Low profile: Great for tool storage
- Wall mountable: Easy to hang for out-of-the-way use
- Heavy-duty cord with daisy chain plug: Allows other electronics to remain plugged in
- One year warranty
- FCC, CE, BC, Square D marked
- Batteries sold separately



CTC772A

CTC772A 14.4 V MicroLithium Battery Charger

- Charges all 7.2 V and 14.4 V Lithium batteries



CTCCORDA2B



CTCCORDA2C



CTCCORDA2L



CTCCORDC2C



CTCCORDC2L

Snap-on® USB Cords

CTCCORDA2B USB Cord Set A-to-B Connection

CTCCORDA2C USB Cord Set A-to-C Connection

CTCCORDA2L USB Cord Set A-to-Lightning Connection

CTCCORDC2C USB Cord Set C-to-C Connection

CTCCORDC2L USB Cord Set C-to-Lightning Connection

- 6-1/2' length allows the user to move around
- Heavy-duty internal aramid fibers for enhanced durability
- Offers extended strain relief protection from pulling and bending
- Welded metal shield design provides EMI protection
- PPE cable jacket is soft and protects against the elements
- Braided cable made with eco-friendly materials provides high friction resistance
- 2.5 A for fast charging



CTS561 Series Screwdriver Accessories

CTEXTSET 4 pc Quick-Change Extensions Set

- Includes CTEXT6 and CTEXT12 quick change extensions plus a T15 TORX® bit (1/4" shank) and a PHILLIPS® bit (power groove hex shank)
- Ideal companion to the CTS series screwdrivers where extended reach is needed

CTEXT6 6" Quick-Change Extension

CTEXT12 12" Quick-Change Extension

- For rotary power tools
- Ideal companion to the CTS561 and CTS561CL Series screwdrivers where extended reach is needed
- Accepts all worldwide industrial standards for hex shanks
- Hardened extension directly transfers rotary power without a loss of torque
- Hex design eliminates slippage and optimizes power
- Hex lock mechanism is better than magnet styles and holds the accessories unit until released
- Maximum RPM: 2,500
- Torque rate: 167 in-lb

CTS561CHUCK 1/4" Quick-Change Keyless Drill Chuck

- 1/4" hex shank for fast changeover
- Compact size improves access and visibility of the drilling surface
- 1/4" chuck capacity provides convenience for small jobs
- 1/32–1/4" drill capacity
- Used for light duty, small holes in metal and wood

CTS561HOLSTR Holster Bit Set

- Includes PHILLIPS® bits #0, #1, #2; flat tip bits 3/16, 7/32, 1/4"; and TORX® bits T15, T25
- Attaches to a belt to keep the bits close for ready use

Power Bit Sets

CTS561BITSET 23 pc 1/4" Drive Quick-Change Bit Set (Blue-Point®)

- For use with Snap-on® cordless screwdrivers and other power drivers
- Manufactured from industrial-grade tool steel
- Includes (22) bits (all 3" long), plus a 1/4" square drive (2" long)
- Includes PHILLIPS® bits #0, #1, #2; flat tip bits 5/32", 3/16", 7/16", 1/4", 9/32"; TORX® bits T10, T15, T20, T25, T27, T30, T40; hex bits 3/32", 7/64, 1/8", 5/32", 3/16", 7/32" and 1/4" in a storage case



CTS561BITSET



GA236C

Engravers

GA236C Engraver (Blue-Point®)

- Marks all materials
- Includes 3 mm tungsten carbide tip
- Nine-position stroke adjustment to control engraving depth
- Soft-coated housing provides better comfort and handling
- Super-smooth action is ideal for precision engraving

GA236C1 Tungsten Carbide Tip (Blue-Point®)

- 3 mm tungsten carbide tip

GA236-32 Diamond Tip

- Optional heavy-duty tip



ETB1580B

Polishers

ETB1580B 7" Variable-Speed Polisher (Blue-Point®)

- Six-position speed setting allows the user to dial in the desired speed
- Soft-start trigger for increased control
- Push-button spindle lock for quick and easy pad changes
- Polishes and details autos, trucks and boats



- Do not use power tool accessories above their maximum rated RPM.
- Read instructions before using power tools.
- Do not use bits with impact driver.
- Read Safety Precautions on pages W1–W4

AIR: QUICK REFERENCE CHART

Impact Wrenches

Stock No.	Drive Size, inches (mm)	Maximum Torque, ft-lb (N•m)	Free Speed, RPM	Blows Per Minute, BPM	Air Consumption, Free Speed, CFM (SCFM) [l/min]	Vibration Level, m/s ²	Sound Level Pressure, dB(A)	Length, inches (mm)	Weight, lb (kg)
PT1800A	1 (25)	1,800 (2,440)	6,500	800	6.7	12.4	103	15 (381)	16.1 (7.3)
PT1800AL	1 (25)	1,800 (2,440)	6,500	800	6.7	12.4	103	19 (483)	17 (7.7)
PT2500	1 (25)	2,500 (3,390)	4,600	800	6.9	12.4	103	17-1/8 (433)	30.36 (13.76)
PT2500L	1 (25)	2,500 (3,390)	4,600	800	6.9	12.4	103	24-3/8 (615)	30.36 (13.76)
AT1300B	1 (25)	2,000 (2,712)	5,000	—	10.8 (—) [305.82]	12.01	108.9	13.59 (345)	23.2 (10.5)
AT1300BL†	1 (25)	2,000 (2,712)	5,000	—	10.8 (—) [305.82]	10.66	108.9	19.53 (496)	26.9 (12.2)
AT670†	3/4 (19)	1,050 (1,423)	6,700 (F), 6,900 (R)	1,050	5.6 (40) [159]	2.44	99	8.5 (216)	7.5 (3.44)
MG1250†	3/4 (19)	1,250 (1,694)	6,200	1,050	6.4 (46) [181]	10.38	99.8	8 (203)	8.1 (3.6)
MG1250L†	3/4 (19)	1,250 (1,694)	6,200	1,050	6.4 (46) [181]	10.38	99.8	10.5 (267)	8.6 (3.99)
MG1250XL†	3/4 (19)	1,250 (1,694)	6,200	1,050	6.4 (46) [181]	10.38	99.8	14.5 (368)	9.5 (4.1)
MG1250P†	3/4 (19)	1,250 (1,694)	6,200	1,050	6.4 (46) [181]	10.38	99.8	8 (203)	8.1 (3.6)
MG725A	1/2 (13)	810 (1,098)	9,800	1,270	5.2 (37) [147]	5.1	102.5	7.7 (194)	4.8 (2.2)
MG725AL	1/2 (13)	810 (1,098)	9,800	1,270	5.2 (37) [147]	5.1	102.5	9.7 (245)	5.0 (2.3)
MG725AP	1/2 (13)	810 (1,098)	9,800	1,270	5.2 (37) [147]	5.1	102.5	7.7 (194)	4.8 (2.2)
PT850	1/2 (13)	810 (1,098)	9,200	1,270	4.1 (29.2) [—]	8.2	98.1	7.2 (183)	4.2 (1.9)
PT850L	1/2 (13)	810 (1,098)	9,200	1,270	4.1 (29.2) [—]	8.2	98.1	9.7 (24.6)	4.3 (2.0)
PT850P	1/2 (13)	810 (1,098)	9,200	1,270	4.1 (29.2) [—]	8.2	98.1	7.2 (183)	4.2 (1.9)
MG3255†	1/2 (13)	325 (440)	10,700	1,400	4 (28) [113]	4.5	99.1	6.1 (155)	2.8 (1.3)
MG3255L†	1/2 (13)	325 (440)	10,700	1,400	4 (28) [113]	4.5	99.1	7.6 (193)	2.9 (1.3)
MG3255P†	1/2 (13)	325 (440)	10,700	1,400	4 (28) [113]	4.5	99.1	6.1 (155)	2.8 (1.3)
MG3255LP†	1/2 (13)	325 (440)	10,700	1,400	4 (28) [113]	4.5	99.1	7.6 (193)	2.9 (1.3)
PT350	1/2 (13)	500 (678)	8,000	1,440	3.17 (22.6) [90]	10.8	97.5	4.95 (126)	3.2 (1.5)
AT2550	1/2 (13)	300 (406)	10,000	1,500	4.3 (—) [121.76]	—	102	4.29 (109)	2.96 (1.34)
AT5500†	1/2 (13)	550 (745)	7,400	1,200	4.2 (30) [118.9]	4.0	94	7.9 (201)	6.4 (2.9)
AT570†	1/2 (13)	570 (773)	6,900 (F), 7,000 (R)	1,050	5.0 (36) [142] (F), 5.3 (38) [150] (R)	6.08	95	7.24 (184)	4.08 (1.87)
MG325†	3/8 (10)	325 (440)	10,700	1,400	4 (28) [113]	4.5	99.1	6.1 (155)	2.8 (1.3)
PT338	3/8 (10)	500 (678)	8,000	1,440	3.17 (22.6) [90]	10.8	97.5	4.8 (122)	3 (1.36)
AT1038	3/8 (10)	190 (257)	4,150	1,950	3.7 (26.6) [104.7]	8.2	94.4	13.15 (334)	3.47 (1.574)
AT2538	3/8 (10)	275 (373)	9,000	1,500	4.3 (—) [—]	8.6	100	4.29 (109)	2.96 (1.34)
AT370†	3/8 (10)	320 (434)	9,000 (F), 9,500 (R)	1,050	4.4 (326) [125] (F), 4.7 (34) [133] (R)	3.25	92	6.3 (160)	2.62 (1.19)
AT380A†	3/8 (10)	175 (230)	8,700	1,680	3.9 (28) [111]	3.5	94	6.5 (165)	3.0 (1.36)
AT351	3/8 (10)	175 (237)	9,700	1,200	2.5 (18) [71]	3.09	96.6	7.6 (193)	2.5 (1.2)
AT235MCA†	1/4 (6)	25 (34)	13,000	2,900	1.67 (12) [47]	<2.5	95.1	6.2 (157)	1.4 (.64)

† CCE

Air Ratchets

Stock No.	Drive Size, inches (mm)	Maximum Torque, ft-lb (N•m)	Free Speed, RPM	Air Consumption, Free Speed, CFM (SCFM) [l/min]	Vibration Level, m/s ²	Sound Level Pressure, dB(A)	Length, inches (mm)	Weight, lb (kg)
PTR50	1/2 (13)	70 (95)	275	4.5 (32) [127]	5.2	92.9	12.1 (308)	2.9 (1.3)
PTR778	1/2 (13)	70 (95)	275	4.5 (32) [127]	5.2	92.9	14.5 (368)	3.5 (1.6)
AT705B†	1/2 (13)	—	150	3.0 (22) [85]	8.7	89	10.7 (273)	2.5 (1.14)
PTR72	3/8 (10)	70 (95)	275	4.5 (32) [127]	5.2	92.9	12.1 (308)	2.9 (1.3)
PTR768	3/8 (10)	70 (95)	275	4.5 (32) [127]	5.2	92.9	14.5 (368)	3.5 (1.6)
PTR838	3/8 (10)	35 (47)	225	1.7 (11) [48]	2.5	84	12.75 (324)	2.4 (1)
PTR2505†	3/8 (10)	0-35 (0-47)	225	1.7 (11) [48]	2.5	84	7.8 (198)	1.4 (.6)
AT208A	3/8 (10)	30 (40.7)	350	3.5 (—) [99.11]	6.81	89	5.12 (130)	1.05 (0.48)
AT238A	3/8 (10)	40 (54.2)	550	2.38 (17) [67.39]	6.2	—	6.3 (160)	1.39 (0.63)
PTR2500†	1/4 (6)	0-35 (0-47)	225	1.7 (11) [48]	2.5	84	7.8 (198)	1.4 (.6)
PTR817	1/4 (6)	35 (47)	225	1.7 (11) [48]	2.5	84	10.5 (267)	1.75 (0.80)
AT700F	3/8 (10)	45 (61)	165	3.0 (22) [85]	8.7	89	10.1 (257)	2.5 (1.14)
AT200D†	1/4 (6)	25 (34)	230	1.4 (10) [40]	3.3	85	8.7 (222)	1.1 (.50)
AT204A†	1/4 (6)	30 (40.6)	350	3.5 (25) [99]	3.6	94	5.12 (130)	1.05 (.48)

† CCE

Air Hammers

Stock No.	Bore Diameter, inches (mm)	Blows Per Minute, BPM	Piston Stroke, inches (mm)	Shank Opening, inches (mm)	Air Consumption, Average, CFM (SCFM) [l/min]	Vibration Level, m/s ²	Sound Pressure Level, dB(A)	Length, inches (mm)	Weight, lb (kg)
PH3050BR	3/4 (19)	2,500	3 (76)	0.401 (10.1)	2.1 (14) [59]	2.8	91.4	9.0 (228)	5.9 (2.7)
AT2050†	3/4 (19)	3,400	2.75 (70)	0.401 (10.1)	2.5 (18) [71]	8.6	99.0	7.4 (188)	4.6 (2.1)

† C€

Drills

Stock No.	Chuck Size, inches (mm)	Rated Power, HP (kW)	Torque Range, in-lb (N•m)	Free Speed, RPM	Air Consumption, Free Speed, CFM (SCFM) [l/min]	Vibration Level, m/s ²	Sound Pressure Level, dB(A)	Length, inches (mm)	Weight, lb (kg)
PDRR2005 [^]	1/4"-28 (Threaded Bits)	0.45 (.33)	—	4,000	3.8 (27) [100]	2.9	84	10 (254)	1.45 (.65)
PDR3000A	3/8 (10)	0.45 (.33)	0-50 (0-6.0)	2,500	3.5 (25) [99]	3.0	79.7	7 (178)	2.2 (1)
PDR3001†	3/8" (10)	.45 (.33)	0-50 (0-6.0)	2,500	3.8 (27) [100]	3.5	83.6	7 (178)	2.2 (1)
PDR5000A	1/2 (13)	0.45 (.33)	0-300 (0-34)	450	3.8 (27) [108]	0.9	82.6	8.7 (222)	3 (1.3)
PDR5001 [^]	1/2 (13)	.45 (.33)	0-300 (0-34)	450	3.8 (27) [108]	0.9	80	8.7 (222)	3 (1.3)
AT184†	5/16 (8)	0.32 (.65)	—	0-1,000/0-1,800	8.4 (60) [238]	<1.0	84	7.9 (201)	3.1 (1.4)
AT3000†	3/8 (10)	0.45 (.33)	0-40 (0-4.5)	1,675	3.5 (25) [95]	<2.5	82	7.6 (193)	3.2 (1.4)
AT5000†	1/2 (13)	0.45 (.33)	0-120 (0-14)	490	3.8 (27) [108]	<2.5	82	9.0 (228)	3.8 (1.7)
AT811†	3/8 (10)	0.45 (.33)	0-55 (0-6)	1,320	3.4 (24) [95]	<.8	110	8.2 (208)	2.2 (1)
AT801MCA†	1/4 (6)	0.25 (.19)	0-18 (0-2.0)	1,800	1.9 (13.6) [53.8]	<2.5	96.4	7.2 (183)	1.5 (0.68)

[^] C€ - DE, ES, FR, IT, GB, NL, JP

† C€ - DE, ES, FR, IT, GB, NL

Die Grinders

Stock No.	Collet Size, inches	Rated Power, HP (kW)	Free Speed, RPM	Air Consumption, Free Speed, CFM (SCFM) [l/min]	Vibration Level, m/s ²	Sound Level dB(A) Pressure	Length, inches (mm)	Weight, lb (kg)
PTGR100†	1/4	1/3 (.2)	25,000	1.7 (11) [48]	2.6	83.3	6.1 (155)	1 (0.4)
PTGR105	1/4	1/3 (.2)	25,000	1.7 (11) [48]	2.69	82.4	9.8 (250)	1.4 (.63)
PTGR110†	1/4	1/3 (.2)	25,000	1.7 (11) [48]	4.8	85.9	5.75 (146)	1.2 (0.5)
PTGR115	1/4	1/3 (.2)	25,000	1.7 (11) [48]	4.4	84.5	9.5 (241)	2.1 (0.95)
PTGR200	1/4	.5 (.3)	23,000	3.2 (23) [90]	2	85.1	6.9 (175)	1.2 (.5)
PTGR205	1/4	.5 (.3)	23,000	3.2 (23) [90]	3	85.9	10.9 (277)	2.1 (0.95)
PTGR210A	1/4	.5 (.3)	23,000	3.2 (23) [90]	5.2	86	6.4 (162)	1.4 (.63)

† C€

Die Grinders (Blue-Point®)

Stock No.	Collet Size, inches	Rated Power, HP (kW)	Free Speed, RPM	Air Consumption, Free Speed, CFM (SCFM) [l/min]	Vibration Level, m/s ²	Sound Level dB(A) Pressure	Length, inches (mm)	Weight, lb (kg)
AT105†	1/4 (6)	0.45 (.33)	22,000	4 (29) [113]	<2.5	102	6.5 (165)	1.3 (.61)
AT109†	1/4 (6)	0.2 (.15)	20,000	2.1 (15) [59]	2.5	93	5.5 (140)	1.1 (.50)
AT115†	1/4 (6)	0.45 (.33)	22,000	4 (29) [113]	<2.5	95	6.5 (165)	1.3 (.61)
AT116†	1/4 (6)	0.2 (.15)	20,000	3 (15) [59]	3	100	6.5 (165)	1.1 (.50)
AT118†	1/4 (6)	0.2 (.15)	20,000	4.0 (29) [113]	2.5	93	5.5 (140)	1.1 (.50)
AT119†	1/4 (6)	0.2 (.15)	20,000	3 (15) [59]	<6.92	100	6.81 (173)	1.1 (.50)
AT120L†	1/4 (6)	0.22 (.164)	23,000	3 (22) [85]	1.83	77	11.02 (280)	1.45 (.66)
AT120LRA†	1/4 (6)	0.45 (.335)	18,000	3.3 (24) [93.4]	1.83	79	11.25 (285)	1.63 (.74)
AT1070A†	1/8 (3)	—	75,000	1 (7) [28]	2.0	72	5.3 (135)	.55 (0.25)
AT1070RA†	1/8 (3)	—	75,000	1 (7) [28]	2.0	72	5.9 (150)	.46 (0.21)

† C€

Heavy-Duty Die Grinders

Stock No.	Collet Size, inches	Rated Power, HP (kW)	Free Speed, RPM	Air Consumption, Free Speed, CFM (SCFM) [l/min]	Vibration Level, m/s ²	Sound Level dB(A) Pressure	Length, inches (mm)	Weight, lb (kg)
PTGR400	1/4	1.0 (.6)	26,000	4.17 (30) [118]	2.1	84.7	7-1/2 (191)	1.5 (.68)
PTGR405	1/4	1.0 (.6)	23,000	4.17 (30) [118]	3.25	82.2	12.25 (311)	2.6 (1.1)
PTGR410	1/4	1.0 (.6)	25,000	4.17 (30) [118]	.78	86.2	7-1/2 (191)	1.5 (0.68)
PTGR450	1/4	1.0 (.6)	12,000	4.17 (30) [118]	8.9	86.3	9.0 (228)	3.25 (1.47)

† C€



• Read and follow safety messages for each type of Air Tool on the following pages and the safety precautions on pages W1-W4

AIR: QUICK REFERENCE CHART

Orbital and Geared Sanders

Stock No.	Pad/Disc Size, Dia., inches (mm)	Style	Rated Power, HP (kW)	Free Speed, RPM	Spindle Thread, inches	Air Consumption, Free Speed, CFM (SCFM) [l/min]	Vibration Level, m/s ²	Sound Level dB(A) Pressure	Length, inches (mm)	Weight, lb (kg)
PSDF4600†	6 (152)	Dual-Function	0.45	1,200	3/8	3 (22) [85]	4.7	79	11 (279)	3.7 (170)
PSDF4600V	6 (152)	Dual-Function	0.45	1,200	3/8	3 (22) [85]	4.7	79	11 (279)	3.7 (170)
PSG4609†	6 (152)	Geared (NV)	0.42 (.33)	1,000	3/8	3 (21.7) [85]	5.9	80	11 (279)	3.7 (1.70)
PSG4609V	6 (152)	Geared (V)	0.42 (.33)	1,000	3/8	3 (21.7) [85]	5.9	80	11 (279)	3.7 (1.70)
PSG4645†	6 (152)	Geared (NV)	0.42 (.33)	1,000	3/8	3 (21.7) [85]	5.9	80	11 (279)	3.7 (1.70)
PSG4645V	6 (152)	Geared (NV)	0.42 (.33)	1,000	3/8	3 (21.7) [85]	5.9	80	11 (279)	3.7 (1.70)
PSG4809†	8 (203)	Geared (NV)	0.42 (.33)	1,000	3/8	3 (21.7) [85]	5.9	80	11 (279)	4 (1.82)
PSG4845†	8 (203)	Geared (NV)	0.42 (.33)	1,000	3/8	3 (21.7) [85]	5.9	80	11 (279)	4 (1.82)
PSG4845V	8 (203)	Geared (NV)	0.42 (.33)	1,000	3/8	3 (21.7) [85]	5.9	80	11 (279)	4 (1.82)
PSO4512†	5 (127)	Orbital	.25(.19)	12,000	5/16"-24	2 (14) [57]	2.1	74.9	6 (152)	1.8 (.82)
PSO4525†	5 (127)	Orbital	.25 (.19)	12,000	1/4"-20	2 (14) [57]	2.3	75.3	6 (152)	1.8 (.82)
PSO4612†	6 (152)	Orbital	.25(.19)	12,000	1/4"-20	2 (14) [57]	2.1	74.9	6.5 (165)	1.8 (.82)
PSO4612V†	6 (152)	Orbital	.25(.19)	12,000	1/4"-20	2 (14) [57]	2.1	74.9	6.5 (165)	1.8 (.82)
PSO4625†	6 (152)	Orbital	.25 (.19)	12,000	1/4"-20	2 (14) [57]	2.3	75.3	6.5 (165)	1.8 (.82)
PSO4625V	6 (152)	Orbital	.25 (.19)	12,000	1/4"-20	2 (14) [57]	2.3	75.3	6.5 (165)	1.8 (.82)
PSOF4312†	3 (76)	Orbital	.25(.19)	12,000	5/16"-24	2 (14) [57]	2.1	74.9	6 (152)	1.7 (.77)
PSOF4612	6 (152)	Orbital	.25(.19)	12,000	1/4"-20	2 (14) [57]	2.1	74.9	6.5 (165)	1.8 (.82)
AT401MCA	3 (76)	Micro Surface Prep	0.25 (.19)	15,000	1/4"-20	2.1 (15) [59]	<2.5	84	4.7 (119)	0.97 (0.44)
AT402MCA	3 (76)	Micro Sander	0.25 (.19)	15,000	5/16"-24 UNF	2.1 (15) [59]	<2.5	84	5.2 (133)	1.1 (0.50)
AT403MCA	3 (76)	Micro Polisher	0.25 (.19)	6,000	5/16"-24 UNF	2.2 (16) [62]	<2.5	86	5.6 (143)	1.3 (0.60)
AT406C	6 (152)	Orbital	.25 (.19)	12,000	5/16"-24	2.5 (18) [71]	2.8	85	8.6 (219)	1.5 (0.7)
AT408	8 (203)	Geared (NV)	0.5 (.37)	850	5/16"-24	5 (36) [142]	3.7	87	11 (279)	4.8 (2.18)
AT411A	6 (152)	Dual Action	0.5 (.37)	10,000	5/16"-18 UNC	5 (36) [142]	3.7	79	8 (203)	4.7 (2.14)
AT425R	5 (127)	Reversible Hi-Speed	0.45 (.33)	13,000	7/16"-20 UNC	4.3 (31) [122]	<0.8	93	5.3 (135)	2.8 (1.28)

† CCE

Cut-Off Tools

Stock No.	Wheel Size, inches (mm)	Rated Power, HP (kW)	Free Speed, RPM	Air Consumption, Free Speed, CFM (SCFM) [l/min]	Vibration Level, m/s ²	Sound Level dB(A) Pressure	Length, inches (mm)	Weight, lb (kg)
PTC250†	3 (76)	0.5 (.37)	23,000	3.2 (23) [90]	6	86.1	7.2 (183)	1.6 (.73)
PTC430†	3 (76)	1.0 (.75)	25,000	4.17 (23) [90]	6.92	87	7-1/2 (191)	1.9 (.86)
PTC490†	4 (102)	1.0 (0.75)	12,000	4.17 (23) [90]	3.41	87.8	9.3 (236)	3 (1.3)
AT154RA*	4 (102)	0.7 (0.5)	13,000	3.1 (22) [87]	3.07	85	14.3 (365)	3.3 (1.5)
AT157R	3 (76)	0.45 (.33)	20,000	3.5 (25) [99]	<3.8	100	7.3 (185)	1.9 (.86)
AT153†	3 (76)	0.5 (0.37)	17,000	3.5 (24) [99.1]	<2.86	85	7.3 (185)	3.3 (1.5)

† CCE

Reciprocating Saws

Stock No.	Free Speed, SPM	Air Consumption, Free Speed, CFM (SCFM) [l/min]	Vibration Level, m/s ²	Sound Pressure Level, dB(A)	Length, inches (mm)	Weight, lb (kg)
PTRS1000	9,000	2.4 (15) [—]	10.0	87.2	8.5 (215)	1.6 (0.73)
AT192A	11,000	1.0 (7) [28]	10.1	94.0	9.3 (235)	1.75 (0.80)
AT194A	8,250	0.7 (5) [20]	<6.6	87.0	6.7 (170)	1 (0.45)

† CCE

AIR: 1" DRIVE IMPACT WRENCHES



PT1800A



PT2500

1" Drive Heavy-Duty Impact Wrenches

Specifications	PT1800A	PT1800AL	PT2500	PT2500L
Drive Size, inches (mm)	1 (25)	1 (25)	1 (25)	1 (25)
Maximum Torque, ft-lb (N•m)	1,800 (2,440)	1,800 (2,440)	2,500 (3,390)	2,500 (3,390)
Working Torque, ft-lb	500–1,200	500–1,200	500–2,100	500–2,100
Free Speed, RPM	6,500	6,500	4,600	4,600
Blows Per Minute	800	800	800	800
Extended Anvil Length, inches (mm)	—	6 (152)	—	8 (203)
Anvil Type	Friction Ring w/ Thru Hole	Friction Ring w/ Thru Hole	Friction Ring w/ Thru Hole	Friction Ring w/ Thru Hole
Air Consumption, CFM	6.7	6.7	6.9	6.9
Air Inlet Thread Size, inches (NPT)	1/2 (14)	1/2 (14)	1/2 (14)	1/2 (14)
Recommended Hose Size, inches (mm)	1/2 (13)	1/2 (13)	1/2 (13)	1/2 (13)
Vibration Level, m/s ²	12.4	12.4	12.4	12.4
Sound Level Pressure, dB(A)	103	103	103	103
Length, inches (mm)	15 (381)	19 (483)	17-1/8 (433)	24-3/8 (615)
Weight, lb (kg)	16.1 (7.3)	17 (7.7)	30.36 (13.76)	30.36 (13.76)

Impact wrench suffix: L = Long anvil. Standard anvil for applications where frequent socket change is required. Long anvil for tight applications that require extra reach

CE - DE, ES, FR, IT, GB, NL, JP

PT1800A 1" Heavy-Duty Impact Wrench

- Lightweight design (16 lb)
- Powerful 1,800 ft-lb of torque output
- Three-speed forward and full-power reverse
- Padded ergonomic side handle for comfortable use
- Rubber nose bumper for tool durability and work piece protection
- Side-directed (reversible) exhaust for cleaner work
- Hard-hitting and durable twin hammer impact mechanism

PT1800AL 1" Heavy-Duty Long Anvil Impact Wrench

PT2500 1" Heavy-Duty Impact Wrench

- Twin hammer for durability
- Powerful 2,500 ft-lb of torque output
- 3-speed forward and full power reverse
- Padded ergonomic side handle for comfortable use
- Aluminum housing

PT2500L 1" Heavy-Duty 8" Long Anvil Impact Wrench

AIR: 1" DRIVE IMPACT WRENCHES (Blue Point®)

1" Drive Heavy-Duty (Blue-Point®)

EU/CE—DE, ES, FR, IT, NL, UK (all models)

Specifications	AT1300B	AT1300BL
Drive Size, inches (mm)	1 (25)	1 (25)
Maximum Torque, ft-lb (N•m)	2,000 (2,712)	2,000 (2,712)
Free Speed, RPM	5,000	5,000
Anvil Type	Friction Ring w/Thru Hole	Friction Ring w/Thru Hole
Air Consumption, Free Speed, CFM (SCFM) [l/min]	10.8 (—) [305.82]	10.8 (—) [305.82]
Air Inlet Thread Size, inches (NPT)	1/2 (14)	1/2 (14)
Recommended Hose Size, inches (mm)	1/2 (13)	1/2 (13)
Vibration Level, m/s ²	12.01	10.66
Sound Level dB(A) Pressure	108.9	108.9
Length, inches (mm)	13.59 (345)	19.53 (496)
Weight, lb (kg)	23.2 (10.5)	26.9 (12.2)

Impact wrench suffix: L = Long anvil. Standard anvil for applications where frequent socket change is required. Long anvil for tight applications that require extra reach

CE - DE, ES, FR, IT, GB, NL

1" Drive Long Anvil Air Impact Wrench (Blue-Point®)

- Durable and powerful pin-less clutch mechanism
- Ergonomic housing design with a steel protector ring
- High-performance motor maximizes output torque
- Side-mounted handle for better operator control
- Optional internal/external trigger set
- Three forward and three reverse speeds
- One year warranty



AT1300B



AT1300BL



- Use only impact sockets and accessories with impact wrenches.
- Avoid prolonged exposure to vibration.
- Read and follow safety messages for each type of Air Tool on following pages and the safety precautions on pages W1–W4

AIR: 3/4" DRIVE IMPACT WRENCHES



MG1250

Colors Available



ADD SUFFIX TO STOCK NUMBER FOR SPECIAL COLORS.



3" Long Anvil (L)



6" Extra-Long Anvil (XL)



Thru-Hole Anvil (P)

MG1250 3/4" Drive Heavy-Duty Air Impact Wrench

- 1,250 ft-lb of torque output removes tough fasteners
- Six-vane rotor for faster motor start-ups
- Twin-hammer impact mechanism and sealed-in oil bath lubrication provide durability and a longer tool life
- Lightweight one-piece housing cuts tool weight to a mere 8.1 lb for superior control and less user fatigue
- Anvil stops with release of trigger to prevent throwing sockets and fasteners
- One-handed reverse button for easy operation

3/4" Drive Super-Duty

Specifications	MG1250
Drive Size, inches (mm)	3/4 (19)
Maximum Torque, ft-lb (N•m)	1,250 (1,694)
Blows Per Minute, BPM	1,050
Anvil Type	Friction Ring
Air Consumption, Free Speed, CFM (SCFM) [l/min]	6.4 (46) [181]
Air Inlet Thread Size, inches (NPT)	3/8 (18)
Recommended Hose Size, inches (mm)	3/8 (10)
Vibration Level, m/s ²	10.38
Sound Level dB(A) Pressure	99.8
Length, inches (mm)	8 (203)
Weight, lb (kg)	8.1 (3.6)
Vinyl Boot	MG1200BOOT

Impact wrench suffix: L = Long anvil. Standard anvil for applications where frequent socket change is required. Long anvil for tight applications that require extra reach
 CE - DE, ES, FR, IT, GB, NL, JP

MG1250L 3/4" Drive Heavy-Duty Long Anvil Magnesium Air Impact Wrench

MG1250XL 3/4" Drive Heavy-Duty Extra-Long Anvil Magnesium Air Impact Wrench

MG1250P 3/4" Drive Heavy-Duty Pinned Anvil Magnesium Air Impact Wrench

AIR: 3/4" DRIVE IMPACT WRENCHES (Blue Point®)



AT670



6" Long Anvil (L)

AT670 3/4" Drive Impact Wrench (Blue-Point®)

- Lightweight composite housing with an aluminum nose
- Three-position thumb-operated forward/reverse lever
- Exhaust is released through the bottom of the handle, away from the work area
- Twin-hammer mechanism

AT670L 3/4" Drive Long Anvil Impact Wrench

3/4" Drive Heavy-Duty (Blue-Point®)

Specifications	AT670
Drive Size, inches (mm)	3/4 (19)
Maximum Torque, ft-lb (N•m)	1,050 (1,423)
Free Speed, RPM	6,700 (F), 6,900 (R)
Blows Per Minute, BPM	1,050
Anvil Type	Friction Ring
Air Consumption, Free Speed, CFM (SCFM) [l/min]	5.6 (40) [159]
Air Inlet Thread Size, inches (NPT)	3/8 (18)
Recommended Hose Size, inches (mm)	3/8 (10) ID min.
Vibration Level, m/s ²	2.44
Sound Pressure Level, dB(A)	99
Length, inches (mm)	8.5 (216)
Weight, lb (kg)	7.5 (3.44)

1/2" Drive Heavy-Duty Impact Wrench

Specifications	MG725A
Drive Size, inches (mm)	1/2 (13)
Maximum Torque, ft-lb (N•m)	810 (1,098)
Free Speed, RPM	9,800
Blows Per Minute, BPM	1,270
Anvil Type	Friction Ring
Air Consumption, Free Speed, CFM (SCFM) [l/min]	5.2 (37) [147]
Air Inlet Thread Size, inches (NPT)	1/4 (18)
Recommended Hose Size, inches (mm)	3/8 (10)
Vibration Level, m/s ²	5.1
Sound Level dB(A) Pressure	102.5
Length, inches (mm)	7.7 (194)
Weight, lb (kg)	4.8 (2.2)
Vinyl Boot	MG725BOOT

Impact wrench suffix: L = Long anvil. Standard anvil for applications where frequent socket change is required. Long anvil for tight applications that require extra reach
 C € - DE, ES, FR, IT, GB, NL, JP

MG725A 1/2" Drive Heavy-Duty Air Impact Wrench

- 1,190 ft-lb (1,613 N•m) bolt breakaway torque and 810 ft-lb (1,098 N•m) working torque
- Faster motor start-up and greater performance with more torque than previous model
- Balanced design for superior control with less user fatigue
- Patented cushion grip handle reduces vibration
- Patented cushion grip tip valve trigger provides comfort and greater tool control
- Anvil stops with release of the trigger to prevent throwing fasteners
- Easy turn regulator for convenient speed control



MG725A

Colors Available

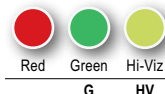

ADD SUFFIX TO STOCK NUMBER FOR SPECIAL COLORS.



Pinned Anvil (P)



Long Pinned Anvil (LP)

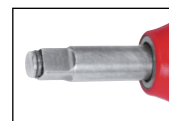

Long Anvil (L)

- Weighs 4.8 lb (2.2 kg)
- Twin hammer impact mechanism is durable and hard hitting
- Sealed in oil bath lubrication with Red Line Synthetic Oil always keeps impact mechanism lubricated for less wear
- Two-year warranty
- For the toughest jobs, choose the maximum power of the MG725A

MG725AL 1/2" Drive Heavy-Duty Long Anvil Air Impact Wrench

MG725AP 1/2" Drive Heavy-Duty Pinned Anvil Air Impact Wrench

1/2" Drive Impact Wrenches

Specifications	PT850
Drive Size, inches (mm)	1/2 (13)
Maximum Torque, ft-lb (N•m)	810 (1,098)
Free Speed, RPM	9,200
Blows Per Minute, BPM	1,270
Air Consumption, CFM	4.1 (29.2) [—]
Anvil Type	Friction Ring
Air Inlet Thread Size, inches (NPT)	1/4 (18)
Air Supply Hose Size, inches (mm) ID	3/8 (9.5)
Sound Power Level, dB(A)	109.7
Sound Level Pressure, dB(A)	98.1
Height, inches (mm)	7.5 (191)
Vibration Level, m/s ²	8.2
Length, inches (mm)	7.2 (183)
Weight, lb (kg)	4.2 (1.9)

Impact wrench suffix: L = Long anvil. Standard anvil for applications where frequent socket change is required. Long anvil for tight applications that require extra reach
 C € - DE, ES, FR, IT, NL, JP

PT850 1/2" Drive Air Impact Wrench

- 1,190 ft-lb (1,613 N•m) bolt breakaway torque and 810 ft-lb (1,098 N•m) working torque
- 1,270 BPM and 9,200 RPM free speed for faster bolt removal
- Forged anvil, frame and hammers for a long tool life
- Cushion grip handle absorbs vibration and insulates the user's hand in cold temperatures



PT850

Colors Available

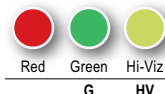

ADD SUFFIX TO STOCK NUMBER FOR SPECIAL COLORS.

- Balanced ergonomic design and slow anvil start-up for greater tool control
- One-handed forward/reverse lever for user convenience
- Large dial type regulator knob

PT850L 1/2" Drive Air Impact (Long Anvil)

PT850P 1/2" Drive Air Impact (Pinned Anvil)



- Use only impact sockets and accessories with impact wrenches.
- Read Safety Precautions on pages W1-W4

AIR: 1/2" DRIVE IMPACT WRENCHES



MG3255

Colors Available



Red Green Hi-Viz
G HV
ADD SUFFIX TO STOCK NUMBER FOR SPECIAL COLORS.



Pinned Anvil (P)



Long Pinned Anvil (LP)

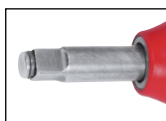

Long Anvil (L)

MG3255 1/2" Drive Air Impact Wrench

- Compact design for easier access
- Balanced lightweight housing provides superior control with less user fatigue
- 425 ft-lb bolt breakaway torque to remove stubborn fasteners
- 10,700 RPM for faster bolt removal
- One-piece machined magnesium housing for precise internal component alignment to reduce vibration
- Anvil stop feature means anvil will stop when the trigger is released to avoid throwing fasteners
- Comfort cushion trigger button allows the user to work comfortably with less finger stress
- Patented field-replaceable cushion grip handle absorbs vibration and insulates the user's hand in cold temperatures



PT350

Colors Available



Red Green Hi-Viz
G HV
ADD SUFFIX TO STOCK NUMBER FOR SPECIAL COLORS.

PT350 1/2" Drive Stubby Air Impact Wrench

- 775 ft-lb (1,017 N•m) bolt breakaway torque and 500 ft-lb (678 N•m) working torque
- Compact design for easier access into tight spaces
- Features a jumbo hammer for added durability
- Ergonomic, lightweight glass-filled nylon housing for less user fatigue

1/2" Drive Impact Wrenches

Specifications	MG3255
Drive Size, inches (mm)	1/2 (13)
Maximum Torque, ft-lb (N•m)	325 (440)
Free Speed, RPM	10,700
Blows Per Minute, BPM	1,400
Anvil Type	Friction Ring
Air Consumption, Free Speed, CFM (SCFM) [l/min]	4 (28) [113]
Air Inlet Thread Size, inches (NPT)	1/4 (18)
Recommended Hose Size, inches (mm)	3/8 (10)
Vibration Level, m/s ²	4.5
Sound Pressure Level, dB(A)	99.1
Length, inches (mm)	6.1 (155)
Weight, lb (kg)	2.8 (1.3)
Vinyl Boot	MG325BOOT
Warranty	2 Year

Impact wrench suffix: L = Long anvil. Standard anvil for applications where frequent socket change is required. Long anvil for tight applications that require extra reach
C € - DE, ES, FR, IT, GB, NL

- Continuous oil bath lubrication prolongs tool life by reducing premature component wear
- Eight-vane motor delivers maximum speed and torque
- Twin-hammer impact mechanism delivers hard-hitting blows with fewer moving parts, quickly removing stubborn fasteners
- One-handed forward/reverse lever for user convenience
- Protective boot and muffler kit are included
- Two-year warranty

MG3255L 1/2" Drive Long Anvil Air Impact Wrench

MG3255LP 1/2" Drive Long Pinned Anvil

Air Impact Wrench

MG3255P 1/2" Drive Pinned Anvil Air Impact Wrench

1/2" Drive Impact Wrenches

Specifications	PT350
Drive Size, inches (mm)	1/2 (13)
Maximum Torque, ft-lb (N•m)	500 (678)
Free Speed, RPM	8,000
Blows Per Minute, BPM	1,440
Anvil Type	Friction Ring
Air Consumption, Free Speed, CFM (SCFM) [l/min]	3.17 (22.6) [90]
Air Inlet Thread Size, inches (NPT)	1/4 (18)
Recommended Hose Size, inches (mm)	3/8 (10)
Vibration Level, m/s ²	10.8
Sound Pressure Level, dB(A)	97.5
Length, inches (mm)	4.95 (126)
Weight, lb (kg)	3.2 (1.5)
Vinyl Boot	PT338BOOT
Warranty	2 Year

C € - DE, ES, FR, IT, GB, NL, JP

- Patent-pending variable speed control
- Patent-pending reversing valve prevents corrosion
- Anvil stops with release of the trigger to prevent throwing fasteners
- Continuous oil bath lubrication prolongs tool life by reducing premature component wear
- Includes protective boot and muffler kit

AIR: 1/2" DRIVE IMPACT WRENCHES (Blue-Point®)



AT2550



AT5500



AT570

1/2" Drive Impact Wrench (Blue-Point®)

Specifications	AT2550	AT5500	AT570
Drive Size, inches (mm)	1/2 (13)	1/2 (13)	1/2 (13)
Maximum Torque, ft-lb (N•m)	300 (406)	550 (745)	570 (773)
Free Speed, RPM	10,000	7,400	6,900 (F), 7,000 (R)
Blows Per Minute, BPM	1,500	1,200	1,050
Anvil Type	Friction Ring	Friction Ring	Friction Ring
Air Consumption, Free Speed, CFM (SCFM) [l/min]	4.3 (—) [121.76]	4.2 (30) [118.9]	5.0 (36) [142] (F), 5.3 (38) [150] (R)
Air Inlet Thread Size, inches (NPT)	1/4 (18)	1/4 (18)	1/4 (18)
Recommended Hose Size, inches (mm)	3/8 (10)	3/8 (10)	3/8 (10)
Vibration Level, m/s ²	—	4.0	6.08
Sound Level dB(A) Pressure	102	94	95
Length, inches (mm)	4.29 (109)	7.9 (201)	7.24 (184)
Weight, lb (kg)	2.96 (1.34)	6.4 (2.9)	4.08 (1.87)
Vinyl Boot	—	AT5500BOOT	AT570BOOT

CE - DE, ES, FR, IT, NL

AT2550 1/2" Drive Compact Impact Wrench (Blue-Point®)

- 300 ft-lb of torque
- Jumbo hammer mechanism
- Thumb-operated forward/reverse lever
- Three forward speeds and one reverse speed
- Exhaust is released through the bottom of the handle, away from the work area
- One year limited warranty

AT5500 1/2" Drive Impact Wrench (Blue-Point®)

- 550 ft-lb of torque, 7,400 RPM, 1,200 BPM
- Built-in five-position adjustable air regulator plus a variable-speed trigger for maximum user control
- Twin-hammer impact mechanism is designed to hit hard yet offer tool longevity
- Ball-bearing-mounted motor creates a smooth running operation for longer tool life
- 1 pc aluminum housing provides a durable tool
- Tapered nose increases accessibility to confined areas
- Inlet filter screens out dirt and grit; easy-to-remove filter for cleaning
- One year limited warranty

AT570 1/2" Drive Air Impact Wrench (Blue-Point®)

- Used on automotive and truck fasteners
- Shot-peen anvils for improved durability
- Reverse-bias motor provides additional torque
- Three-position regulator to control power
- One-handed forward/reverse lever for user convenience
- Composite housing with an aluminum nose combine to deliver a durable, lightweight and balanced unit
- Twin-hammer impact mechanism delivers hard-hitting blows to quickly remove stubborn fasteners

1/4" Drive (Blue-Point®)

Specifications	AT235MCA
Drive Size, inches (mm)	1/4 (6)
Maximum Torque, ft-lb (N•m)	25 (34)
Air Consumption, Free Speed, CFM (SCFM) [l/min]	1.67 (12) [47]
Air Inlet Thread Size, inches (NPT)	1/4 (18)
Blows Per Minute, BPM	2,900
Free Speed, RPM	13,000
Recommended Hose Size, inches (mm)	3/8 (10) ID min.
Sound Pressure Level, dB(A)	95.1
Vibration Level, m/s ²	<2.5
Length, inches (mm)	6.2 (157)
Weight, lb (kg)	1.4 (.64)

AT235MCA 1/4" Drive Micro Impact Wrench (Blue-Point®)

- 25 ft-lb of torque
- Balanced, lightweight, reduces fatigue
- Durable composite housing
- Oversized trigger with variable-speed
- Convenient one-handed forward/reverse lever
- Exhaust is released through the bottom of the handle, away from the work area



AT235MCA



- Use only impact sockets and accessories with impact wrenches.
- Read Safety Precautions on pages W1-W4

AIR: 3/8" DRIVE IMPACT WRENCHES



MG325



PT338

3/8" Drive Super-Duty Impact Wrench

Specifications	MG325
Drive Size, inches (mm)	3/8 (10)
Maximum Torque, ft-lb (N•m)	325 (440)
Free Speed, RPM	10,700
Blows Per Minute, BPM	1,400
Anvil Type	Friction Ring
Air Consumption, Free Speed, CFM (SCFM) [l/min]	4 (28) [113]
Air Inlet Thread Size, inches (NPT)	1/4 (18)
Recommended Hose Size, inches (mm)	3/8 (10)
Vibration Level, m/s ²	4.5
Sound Pressure Level, dB(A)	99.1
Length, inches (mm)	6.1 (155)
Weight, lb (kg)	2.8 (1.3)
Vinyl Boot	MG325BOOT

Impact wrench suffix: L = Long anvil. Standard anvil for applications where frequent socket change is required. Long anvil for tight applications that require extra reach
 (€ - DE, ES, FR, IT, GB, NL

MG325 3/8" Drive Air Impact Wrench

- Compact size and slim-style nose is great for working in tight spaces
- Balanced lightweight housing provides superior control with less user fatigue
- 425 ft-lb (576 N•m) bolt breakaway torque and 325 ft-lb (440 N•m) working torque
- 10,700 RPM for faster bolt removal
- One-piece machined magnesium housing for precise internal component alignment to reduce vibration
- Anvil stop feature means anvil will stop when the trigger is released to avoid throwing fasteners
- Comfort cushion trigger button allows the user to work comfortably with less finger stress
- Patented field-replaceable cushion grip handle absorbs vibration and insulates the user's hand in cold temperatures
- Continuous oil bath lubrication prolongs tool life by reducing premature component wear
- Eight-vane motor delivers maximum speed and torque
- Twin-hammer impact mechanism delivers hard-hitting blows with fewer moving parts, quickly removing stubborn fasteners
- One-handed forward/reverse lever for user convenience
- Protective boot and muffler kit are included
- Two-year warranty

Colors Available

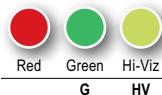

ADD SUFFIX TO STOCK NUMBER FOR SPECIAL COLORS.

3/8" Drive Super-Duty Impact Wrench

Specifications	PT338
Drive Size, inches (mm)	3/8 (10)
Maximum Torque, ft-lb (N•m)	500 (678)
Free Speed, RPM	8,000
Blows Per Minute, BPM	1,440
Anvil Type	Friction Ring
Air Consumption, Free Speed, CFM (SCFM) [l/min]	3.17 (22.6) [90]
Air Inlet Thread Size, inches (NPT)	1/4 (18)
Recommended Hose Size, inches (mm)	3/8 (10)
Vibration Level, m/s ²	10.8
Sound Pressure Level, dB(A)	97.5
Length, inches (mm)	4.8 (122)
Weight, lb (kg)	3 (1.36)
Vinyl Boot	PT338BOOT

Impact wrench suffix: L = Long anvil. Standard anvil for applications where frequent socket change is required. Long anvil for tight applications that require extra reach
 (€ - DE, ES, FR, IT, GB, NL

PT338 3/8" Drive Stubby Air Impact Wrench

- 500 ft-lb (678 N•m) of working torque
- 770 ft-lb (950 N•m) bolt breakaway torque
- Compact design for greater access in tight spaces
- Ergonomic, lightweight glass-filled nylon housing for less user fatigue
- Features a jumbo hammer for added durability
- Patent-pending variable speed control
- Patent-pending reversing valve prevents corrosion
- Anvil stops with release of the trigger to prevent throwing fasteners
- Continuous oil bath lubrication prolongs life of the tool by reducing premature component wear
- Includes protective boot

Colors Available

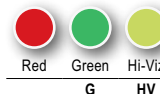

ADD SUFFIX TO STOCK NUMBER FOR SPECIAL COLORS.

AIR: 3/8" DRIVE IMPACT WRENCHES (Blue-Point®)



AT1038



AT2538



AT370



AT380A



AT351

3/8" Drive Heavy-Duty (Blue-Point®)

Specifications	AT1038	AT2538	AT370	AT380A	AT351
Drive Size, inches (mm)	3/8 (10)	3/8 (10)	3/8 (10)	3/8 (10)	3/8 (10)
Maximum Torque, ft-lb (N•m)	190 (257)	275 (373)	320 (434)	175 (230)	175 (237)
Free Speed, RPM	4,150	9,000	9,000 (F), 9,500 (R)	8,700	9,700
Blows Per Minute, BPM	1,950	1,500	1,050	1,680	1,200
Air Consumption, Free Speed, CFM (SCFM) [l/min]	3.7 (26.6) [104.7]	4.3 (—) [—]	4.4 (326) [125] (F), 4.7 (34) [133] (R)	3.9 (28) [111]	2.5 (18) [71]
Air Inlet Thread Size, inches (NPT)	1/4 (18)	1/4 (18)	1/4 (18)	1/4 (18)	1/4 (18)
Recommended Hose Size, inches (mm)	—	—	3/8 (10)	3/8 (10)	3/8 (10) ID min.
Vibration Level, m/s ²	8.2	8.6	3.25	3.5	3.09
Sound Level dB(A) Pressure	94.4	100	92	94	96.6
Length, inches (mm)	13.15 (334)	4.29 (109)	6-3/10 (160)	6.5 (165)	7.6 (193)
Weight, lb (kg)	3.47 (1.574)	2.96 (1.34)	2.62 (1.19)	3.0 (1.36)	2.5 (1.2)
Vinyl Boot	—	—	AT370BOOT	AT380ABOOT	—

CE - DE, ES, FR, IT, GB, NL

AT1038 3/8" Drive Right Angle Impact Wrench (Blue-Point®)

- Low-profile right-angle head for access to tight spaces
- Hard-hitting jumbo hammer mechanism
- Multiple speed settings—two forward and one reverse
- Forward/reverse lockout mechanism
- Variable-speed trigger
- Gear oil lubrication for reduced component wear and longer tool life
- One year limited warranty

AT2538 3/8" Drive Compact Air Impact Wrench (Blue-Point®)

- 275 ft-lb of torque
- Jumbo hammer mechanism
- Thumb-operated forward/reverse lever
- Three forward speeds and one reverse
- Exhaust is released through the bottom of the handle, away from the work area
- One year warranty

AT370 3/8" Drive Impact Wrench (Blue-Point®)

- Used on automotive and truck fasteners
- Shot-peen anvils for improved durability
- Reverse-bias motor provides additional breakaway torque
- Three-position regulator to control power
- One-handed forward/reverse lever for convenient use
- Composite housing with an aluminum nose combine to deliver a durable, lightweight and balanced unit
- Twin-hammer impact mechanism delivers hard-hitting blows to quickly remove stubborn fasteners

AT380A 3/8" Drive Impact Wrench (Blue-Point®)

- Built-in, five-position adjustable air regulator plus a variable-speed trigger for maximum user control
- Aluminum housing provides a lightweight yet durable tool
- Tapered nose increases accessibility to confined areas
- Ball-bearing-mounted motor creates a smooth-running operation for less user fatigue
- Brass inlet filter screens out dirt and grit; easy-to-remove filter for cleaning
- Twin-hammer impact mechanism is designed to hit hard yet offer tool longevity
- One year limited warranty

AT351 3/8" Drive Impact Wrench (Blue-Point®)

- Built-in air inlet swivel
- Eight-position power regulator
- Rotary action air motor is ball bearing mounted for balance, speed and power
- Ideal tool for small engine repair and bench work



- Use only impact sockets and accessories with impact wrenches.
- Avoid prolonged exposure to vibration.
- Read Safety Precautions on pages W1-W4

AIR: 1/2", 3/8" DRIVE RATCHETS



PTR50



PTR768



PTR72



PTR778

Air Ratchets

Specifications	PTR50	PTR72*	PTR768	PTR778
Drive Size, inches (mm)	1/2 (13)	3/8 (10)	3/8 (10)	1/2 (13)
Maximum Torque, ft-lb (N•m)	70 (95)	70 (95)	70 (95)	70 (95)
Air Consumption, Free Speed, CFM (SCFM) [l/min]	4.5 (32) [127]	4.5 (32) [127]	4.5 (32) [127]	4.5 (32) [127]
Recommended Hose Size, inches (mm)	3/8 (10)	3/8 (10)	3/8 (10)	3/8 (10)
Vibration Level, m/s ²	5.2	5.2	5.2	5.2
Sound Level dB(A) Pressure	92.9	92.9	92.9	92.9
Length, inches (mm)	12.1 (308)	12.1 (308)	14.5 (368)	14.5 (368)
Vinyl Boot	YA889 (included)	YA889 (included)	YA889 (included)	YA889 (included)
Warranty	2 Year	2 Year	2 Year	2 Year

CE - DE, ES, FR, IT, GB, NL, JP

PTR50 1/2" Drive Super-Duty Air Ratchet

- 70 ft-lb of torque output to remove stubborn fasteners
- Easily withstands 158 ft-lb of manual torque
- 275 RPM free speed for fast removal and installation of fasteners
- “Stop lock” pins prevent ratchet pawl lockup
- Steel wear bushings reduce ratchet head wear
- Dual-pawls for added strength
- Tip valve-style trigger is easy to feather for greater control
- Large selector knob for easy direction change
- Adjustable composite exhaust directs the airflow away from work
- Cushion grip for added comfort and control

PTR72 3/8" Drive Super-Duty Air Ratchet

- 70 ft-lb of torque output removes stubborn fasteners
- Easily withstands 158 ft-lb of manual torque
- 275 RPM free speed for quick fastener removal and installation
- “Stop lock” pins prevent ratchet pawl lockup
- Steel wear bushings reduce ratchet head wear
- Dual-pawls for added strength
- Tip valve-style trigger is easy to feather for greater control
- Large selector knob for easy direction change
- Adjustable composite exhaust directs the airflow away from work
- Cushion grip for added comfort and control

PTR768 3/8" Drive Long-Neck Air Ratchet

- 70 ft-lb of torque handles the big jobs
- 158 ft-lb of manual torque to loosen rusty fasteners
- 275 RPM reduces fastener removal time
- 14-1/2" long for access
- Cushion grip handle for positive tool control
- Dual pawls for added strength
- Stop lock pins prevent ratchet lock up
- Steel wear bushing reduces ratchet head wear
- Tip valve trigger for featherability

PTR778 1/2" Drive Long-Neck Air Ratchet

- 70 ft-lb of torque handles the big jobs
- 158 ft-lb of manual torque to loosen rusty fasteners
- 275 RPM reduces fastener removal time
- 14-1/2" long for access
- Cushion grip handle for positive tool control
- Dual pawls for added strength
- Stop lock pins prevent ratchet lock up
- Steel wear bushing reduces ratchet head wear
- Tip valve trigger for featherability

Colors Available



Red Green Hi-Viz

* G HV
ADD SUFFIX TO STOCK NUMBER FOR SPECIAL COLORS.



PTR2500



PTR838



PTR2505



PTR817

Air Ratchets

Specifications	PTR2500	PTR2505	PTR838	PTR817
Drive Size, inches (mm)	1/4 (6)	3/8 (10)	3/8 (10)	1/4 (6)
Maximum Torque, ft-lb (N•m)	0–35 (0–47)	0–35 (0–47)	35 (47)	35 (47)
Air Pressure Working, PSI (kPa)	90 (620)	90 (620)	90 (620)	90 (620)
Air Consumption, Free Speed, CFM (SCFM) [l/min]	1.7 (11) [48]	1.7 (11) [48]	1.7 (11) [48]	1.7 (11) [48]
Torque Range, ft-lb (N•m)	0–35 (0–47)	0–35 (0–47)	0–35 (0–47)	0–35 (0–47)
Recommended Hose Size, inches (mm)	3/8 (10)	3/8 (10)	3/8 (10)	—
Vibration Level, m/s ²	2.5	2.5	2.5	2.5
Sound Level dB(A) Pressure	84	84	84	84
Length, inches (mm)	7.8 (198)	7.8 (198)	12.75 (324)	10.5 (267)
Vinyl Boot	YA905 (included)	YA905 (included)	YA889 (included)	YA889 (included)
Warranty	1 Year	1 Year	1 Year	1 Year

*CE - DE, ES, FR, IT, GB, NL, JP

PTR2500 1/4" Drive Mini Air Ratchet

- 225 RPM free speed in a compact size for greater access to tight spaces
- Balanced, lightweight housing for superior comfort and control with less user fatigue
- Large forward/reverse knob makes it easy to switch directions, even with greasy hands
- Soft grip handle provides increased comfort and insulation from the cold, while reducing vibration
- Zerk fitting allows the ratchet head to be lubricated for longer tool life
- Variable-speed trigger allows for slow motor start-ups

PTR2505 3/8" Drive Mini Air Ratchet

- Balanced lightweight housing for superior comfort and control with less user fatigue
- Soft grip handle provides increased comfort while reducing vibration and insulating from the cold
- Large forward/reverse knob makes it easy to switch directions even with greasy hands
- Zerk fitting allows ratchet head to be lubricated for longer tool life
- Variable-speed trigger allows for slow motor start ups

PTR838 3/8" Drive Long-Neck Air Ratchet

- Long neck ratchet with extra-long reach for those hard-to-reach fasteners
- Soft grip handle provides increased comfort and insulation from the cold while reducing vibration
- Larger forward/reverse knob makes it easy to switch directions even with greasy hands
- Zerk fitting allows ratchet head to be lubricated for longer tool life
- Variable-speed trigger allows for slow motor start-ups
- Balanced lightweight housing for superior comfort and control with less user fatigue
- Manual torque load of 46 ft-lb

PTR817 1/4" Drive Long-Neck Air Ratchet

- Extra-long reach to access hard-to-reach fasteners
- Soft grip handle provides increased comfort and insulation from the cold, while reducing vibration
- Large forward/reverse knob makes it easy to switch directions, even with greasy hands
- Zerk fitting allows ratchet head to be lubricated for longer tool life
- Variable-speed trigger allows for slow motor start-ups
- Balanced, lightweight housing for superior comfort and control with less user fatigue
- Withstands 46 ft-lb of manual torque

Colors Available

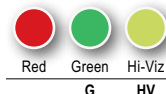

ADD SUFFIX TO STOCK NUMBER FOR SPECIAL COLORS.



- Use only impact sockets and accessories with air ratchets.
- Read Safety Precautions on pages W1–W4

AIR: 1/2" DRIVE RATCHETS (Blue Point®)



AT200D



AT204A



AT208A



AT238A



AT700F



AT705B

Air Ratchets (Blue-Point®)

Specifications	AT200D	AT204A	AT208A	AT238A	AT700F	AT705B
Drive Size, inches (mm)	1/4 (6)	1/4 (6)	3/8 (10)	3/8 (10)	3/8 (10)	1/2 (13)
Torque Range, ft-lb (N•m)	5-25 (6-34)	0-30 (0-40.6)	0-30 (0-40.6)	0-40 (0-54.2)	5-45 (6-61)	5-50 (6-68)
Free Speed, RPM	230	350	350	550	165	150
Air Consumption, Free Speed, CFM (SCFM) [l/min]	1.4 (10) [40]	3.5 (25) [99]	3.5 (—) [99.11]	2.38 (17) [67.39]	3.0 (22) [85]	3.0 (22) [85]
Air Inlet Thread Size, inches (NPT)	1/4 (18)	1/4 (18)	1/4 (18)	1/4 (18)	1/4 (18)	1/4 (18)
Recommended Air Pressure, PSIG (kPa)	90 (620)	90 (620)	90 (620)	90 (620)	90 (620)	90 (620)
Vibration Level, m/s ²	3.3	3.6	6.81	6.2	8.7	8.7
Sound Level dB(A) Pressure	85	94	89	—	89	89
Length, inches (mm)	8.7 (222)	5.12 (130)	5.12 (130)	6.3 (160)	10.1 (257)	10.7 (273)
Weight, lb (kg)	1.1 (.50)	1.05 (.48)	1.05 (0.48)	1.39 (0.63)	2.5 (1.14)	2.5 (1.14)
Vinyl Boot	AT200D22A	AT238-36	AT238-36	AT238-36	AT700E49A	AT700E49A

CE - DE, ES, FR, IT, GB, NL

AT200D 1/4" Drive Air Ratchet (Blue-Point®)

- 20 ft-lb maximum torque
- Lightweight aluminum housing
- Rugged ball bearing-mounted air motor and precision planetary gear system
- Includes vinyl boot

AT204A 1/4" Drive Mini Air Ratchet (Blue-Point®)

- Ideal for working in tight quarters
- Head clearance is less than 3/4"
- Includes variable-speed trigger, adjustable air regulator and 5' nylon braided whip hose for maneuverability and control
- Composite housing provides strength and durability

AT208A 3/8" Mini Air Ratchet Wrench (Blue-Point®)

- Compact size allows for greater access to tight spaces
- Easy to use with a variable-speed throttle
- 30 ft-lb torque
- Lightweight design reduces fatigue
- Comfort grip, head boot and 5' braided PU hose
- One year limited warranty

AT238A 3/8" Drive Mini Impacting Ratchet Wrench (Blue-Point®)

- Reaction-free clutch mechanism prevents kick-back
- 40 ft-lb torque
- Compact size allows for greater access to tight spaces
- Lightweight design reduces fatigue
- 1/4"-18 NPT air inlet thread size
- One year limited warranty

AT700F 3/8" Drive Ratchet (Blue-Point®)

- Delivers 5-45 ft-lb of torque
- Rugged ball bearing mounted air motor and precision planetary gear system
- Easy-to-use variable-speed throttle plus adjustable air regulator
- Lightweight aluminum housing

AT705B 1/2" Drive Ratchet (Blue-Point®)

- 1/2" drive ratchet in a 3/8" drive body
- Ball bearing mounted motor for longer tool life



1/2 and 3/8" Capacity Drills

Specifications	PDR5000A*	PDR5001**	PDR3000A*	PDR3001**	PDRR2005^
Chuck Size, inches (mm)	1/2 (13)	1/2 (13)	3/8 (10)	3/8" (10)	1/4"-28 (Threaded Bits)
Rated Power, HP (kW)	0.45 (.33)	.45 (.33)	0.45 (.33)	.45 (.33)	0.45 (.33)
Torque Range, in-lb (N•m)	0-300 (0-34)	0-300 (0-340)	0-50 (0-6.0)	0-50 (0-6.0)	—
Free Speed, RPM	450	450	2,500	2,500	4,000
Spindle Thread, inches	1/2"-20 UNF	1/2"-20 UNF	3/8"-24 UNF	3/8"-24 UNF	1/4"-28
Air Consumption, Average, CFM (SCFM) [l/min]	3.8 (27) [108]	3.8 (27) [108]	3.5 (25) [99]	3.8 (27) [100]	3.8 (27) [100]
Air Inlet Thread Size, inches (NPT)	1/4 (18)	1/4 (18)	1/4 (18)	1/4 (18)	1/4 (18)
Recommended Hose Size, inches (mm)	3/8 (10)	3/8 (10)	3/8 (10)	3/8" (10)	3/8 (10)
Vibration Level, m/s ²	0.9	0.9	3.0	3.5	2.9
Sound Power Level, dB(A)	108.0	82.6	106.1	95.2	84
Length, inches (mm)	8.7 (222)	8.7 (222)	7 (178)	7 (178)	10 (254)
Auxiliary Handle	PDR5000-40A	PDR5000-40A	—	—	—
Chuck Key	30429	—	30002	—	—
Chuck Type	Keyed	Keyless	Keyed	Keyless	—
Replacement Chuck	PDR5000-2	—	21133B	—	—
Keyless Chuck	PDR5000-2	SP68187	PDR3A-2	PDR3000-2	—

*CE - DE, ES, FR, IT, GB, NL

^CE - DE, ES, FR, IT, GB, NL, JP

PDR5000A 1/2" Capacity Reversible Drill

- Five-vane air motor delivers high-torque power for added durability
- Three-planet industrial strength gear train provides durability for heavy-duty applications
- Precise .0025" chuck run-out for precision drilling
- Includes side handle for added control in high-torque drilling applications

PDR5001 1/2" Capacity Keyless Chuck Reversible Drill

- Top-mounted one-handed forward/reverse for ease of use
- Variable-speed trigger for added control
- Cushion grip handle reduces vibration and insulates from the cold
- Internal ball bearing construction for smooth operation
- Five-vane air motor for faster start-ups and more power
- 450 RPM and 300 in-lb of torque output

PDR3000A 3/8" Capacity Reversible Drill

- Convenient top-mounted forward/reverse switch allows for one-handed operation
- Five-vane air motor provides more drilling power to get the job done faster
- Overmolded cushion handle insulates from cold and vibration to reduce user fatigue
- Reversible variable-speed trigger for more control of drilling speed allows for precise drilling and increased safety
- Internal ball bearing construction for smooth operation and extended tool life
- Three-planet industrial strength gear train provides durability for heavy-duty drilling applications

- Precise .0025 chuck runout which enables precision drilling yielding a high-quality job
- Ergonomically designed lightweight aluminum housing provides a high power-to-weight ratio, allowing more productivity with less fatigue

PDR3001 3/8" Capacity Keyless Chuck Reversible Drill

- 2,500 RPM and 50 in-lb of torque output
- One-handed forward/reverse for ease of use
- Excellent runout for consistent drilling, reaming and honing
- Keyless chuck for rapid bit change
- Slow start-up for easy control
- Handle exhaust directs air downward
- All ball and needle bearing spindle components
- Machined planetary gears balance the load
- Cushion grip handle reduces vibration and insulates from the cold
- Internal ball bearing construction for smooth operation
- Five vane air motor for faster start ups and more power
- Industrial drivetrain and gearing for long tool life

PDRR2005 Mini Right Angle Air Drill

- Compact head for access to tight spaces
- Low spindle runout for precise drilling
- Accepts bits with 1/4"-28 thread
- Spindle shaft supported by double bearings for increased durability
- Spiral bevel gears for durability and smooth operation
- Variable-speed trigger maximizes performance and control

Colors Available



* G HV

ADD SUFFIX TO STOCK NUMBER FOR SPECIAL COLORS.



- Use only impact sockets and accessories with air ratchets.
- Read Safety Precautions on pages W1-W4

AIR: 1/4" CAPACITY DRILLS



PDYT1KE



PDZT2LK

1/4" Capacity Drills

	Stock No.	Description
1/4" Capacity Keyed Chuck Reversible	PDYT1KE	.3 HP 1,800 RPM Pneumatic Drill
	PDYT1KF	.3 HP 2,000 RPM Pneumatic Drill
	PDYT1KG	.3 HP 2,400 RPM Pneumatic Drill
	PDYT1KH	.3 HP 3,000 RPM Pneumatic Drill
1/4" Capacity Keyed Chuck Non-Reversing	PDZT2K7	.5 HP 2,600 RPM Pneumatic Drill
	PDZT2KH	.5 HP 3,000 RPM Pneumatic Drill
	PDZT2KK	.5 HP 3,600 RPM Pneumatic Drill
	PDZT2KL	.5 HP 4,300 RPM Pneumatic Drill
1/4" Capacity Keyless Chuck Non-Reversing	PDZT2KN	.5 HP 23,000 RPM Pneumatic Drill
	PDZT2L7	.5 HP 2,600 RPM Pneumatic Drill
	PDZT2LH	.5 HP 3,000 RPM Pneumatic Drill
	PDZT2LK	.5 HP 3,600 RPM Pneumatic Drill
	PDZT2LL	.5 HP 4,300 RPM Pneumatic Drill
	PDZT2LN	.5 HP 23,000 RPM Pneumatic Drill

Specifications: 1/4" Capacity Pneumatic Drills	
Length, inches (mm)	6.3 (160)
Weight, lb (kg)	1.5 (0.7)
Recommended Hose Size, inches (mm)	3/8 (10)
Spindle Thread	3/8"-24
Warranty	1 Year

CE - DE, ES, FR, IT, GB, NL

1/4" Capacity Pneumatic Drills Feature:

- Inlayed grip provides comfortable, low-profile padding and reduces fatigue while guiding users to hold the tool properly to enhance accuracy
- Ergonomic Support: Located on both sides of the housing, this support provides a resting point for the index finger during operation; aviation drills should be held so that the operator's wrist and index finger are inline with the chuck to enhance precision and control while reducing user fatigue
- Featherable throttle enhances flow to feed the high-torque motor and offers precise control for critical applications
- Dual-chamber motor provides high-torque for stubborn applications
- High Stall Torque: Bit jammed? Pull the trigger and turn clockwise—this feature saves time and frustration
- 3-Planet Gear Carrier: Designed for industrial applications to enhance precision and durability versus conventional two-gear models
- Röhme® Keyed Chuck: 1/4" (6.5 mm) premium quality chuck for critical applications
- Reversible and non-reversible models available

Spotweld Drill

Specifications	AT184
Chuck Size, inches (mm)	5/16 (8)
Rated Power, HP (kW)	0.32 (.65)
Free Speed, RPM	0-1,000/0-1,800
Air Consumption, Free Speed, CFM (SCFM) [l/min]	8.4 (60) [238]
Air Inlet Thread Size, inches (NPT)	1/4 (18)
Recommended Hose Size, inches (mm)	3/8 (10)
Sound Level dB(A) Pressure	84
Length, inches (mm)	7.9 (201)
Weight, lb (kg)	3.1 (1.4)
Spotweld Drill Bit (10 mm) (optional)	AT183-51
Spotweld Drill Bit (6.5 mm) (optional)	AT183-43
Spotweld Drill Bit (8 mm) (included)	AT183-50
Support Arm 5.5 (optional)	AT184-26A



AT184

AT184 Spotweld Drill (Blue-Point®)

- Twist depth control collar allows precise setting of drilling depth up to 1/4"
- Two-speed trigger for low or high-speeds
- Includes (1) 5/16" (8 mm) drill bit and removeable clamp arm

AT3000 3/8" Reversible Drill (Blue-Point®)

- Convenient one-handed forward/reverse operation
- Exhaust is released through the bottom of the handle, away from the work area
- Comfort grip handle
- Keyless chuck saves time when changing bits



AT3000

AT5000 1/2" Reversible Drill (Blue-Point®)

- Chuck key conveniently stores in the handle
- Variable-speed trigger
- Convenient one-handed forward/reverse operation
- Exhaust is released through the bottom of the handle, away from the work area



AT5000

AT801MCA 1/4" Micro Drill (Blue-Point®)

- Small size is ideal for working in confined areas
- Durable composite housing stands up to rugged use
- Reverse lever is conveniently positioned for one-handed operation
- Oversized variable-speed trigger



AT811

AT811 3/8" Angle Drill (Blue-Point®)

- Convenient one-handed push-button forward/reverse operation
- Rear exhaust keeps air away from the work area
- Ball-bearing construction for longer tool life



AT801MCA

1/4, 3/8 and 1/2" Drills (Blue-Point®)

Specifications	AT3000	AT5000	AT811	AT801MCA
Chuck Size, inches (mm)	3/8 (10)	1/2 (13)	3/8 (10)	1/4 (6)
Rated Power, HP (kW)	0.45 (.33)	0.45 (.33)	0.45 (.33)	0.25 (.19)
Torque Range, in-lb (N•m)	0-40 (0-4.5)	0-120 (0-14)	0-55 (0-6)	0-18 (0-2.0)
Free Speed, RPM	1,675	490	1,320	1,800
Spindle Thread, inches	3/8"-24 UNF	1/2"-20 UNF	3/8"-24 UNF	3/8"-24 UNF
Air Consumption, Average, CFM (SCFM) [l/min]	3.5 (25) [95]	3.8 (27) [108]	3.4 (24) [95]	1.9 (13.6) [53.8]
Air Inlet Thread Size, inches (NPT)	1/4 (18)	1/4 (18)	1/4 (18)	1/4 (18)
Recommended Hose Size, inches (mm)	3/8 (10)	3/8 (10)	3/8 (10) ID min.	3/8 (10) ID min.
Vibration Level, m/s ²	<2.5	<2.5	<.8	<2.5
Sound Level dB(A) Pressure	82	82	110	96.4
Length, inches (mm)	7.6 (193)	9.0 (228)	8.2 (208)	7.2 (183)
Weight, lb (kg)	3.2 (1.4)	3.8 (1.7)	2.2 (1)	1.5 (0.68)
Auxiliary Handle	—	PDAH1A	—	—
Vinyl Boot (opt.)	AT3000BOOT	AT5000BOOT	—	—



- Use only impact sockets and accessories with air ratchets.
- Read Safety Precautions on pages W1-W4

AIR: HAMMERS



PH3050BR



AT2050

Colors Available



* Red Green Hi-Viz
G HV
ADD SUFFIX TO STOCK NUMBER FOR SPECIAL COLORS.

PH3050BR Super-Duty Air Hammer

- 2,500 BPM with hardened steel piston, delivering harder blows for maximum impact
- Dual elastomer cushions absorb shock and vibration, reducing user fatigue
- Phenolic (Kevlar® reinforced) flutter disc provides long life
- Direct multiport front exhaust keeps air and debris away from user
- High-grade steel barrel provides greater strength
- Variable-speed soft-touch trigger provides featherability for greater control
- Four-position built-in air regulator varies power for different applications
- Air line screen helps prevent foreign particles from clogging trigger mechanism
- Includes PH200D Quick Change Chuck Retainer

Retainer Chuck

PH200D Universal Quick-Change Chuck Retainer

- Use for fast and easy insertion/removal of air hammer bits
- Non-turning insert design reduces wear for longer tool life
- Constructed from high-grade steel—insert is constructed from durable polyurethane elastomer
- Universal design fits most air hammers
- Knurled collar provides a solid gripping surface, even with greasy hands



PH200D

Super-Duty Air Hammers

Specifications	PH3050BR†*	AT2050†
Bore Diameter, inches (mm)	3/4 (19)	3/4 (19)
Blows Per Minute, BPM	2,500	3,400
Piston Stroke, inches (mm)	3 (76)	2.75 (70)
Shank Opening, inches (mm)	0.401 (10.1)	0.401 (10.1)
Air Consumption, Free Speed, CFM (SCFM) [l/min]	2.1 (14) [59]	2.5 (18) [71]
Air Inlet Thread Size, inches (NPT)	1/4 (18)	1/4 (18)
Recommended Hose Size, inches (mm)	5/16 (8)	5/16 (8)
Vibration Level, m/s ²	2.8	8.6
Sound Level dB(A) Pressure	91.4	99
Length, inches (mm)	9.0 (228)	7.4 (188)
Weight, lb (kg)	5.9 (2.7)	4.6 (2.1)
Vinyl Boot	PH3050RBOOT	AT2050BOOT

†€ - DE, ES, FR, IT, GB, NL

- Intended for heavier-duty applications like cutting large bolts and rivets, separating ball joints, cutting heavy gauge sheet metal and driving bushings

PH3050BRCH4 Super-Duty Air Hammer Set

- Set includes Air hammer (PH3050BR), Quick Change Retainer (PH200D), Flat Chisel (PHG55A), Panel Cutter (PHG57B), Tapered Punch (PHG59A) and Muffler Cutter (PHG87)

AT2050 Heavy-Duty Air Hammer (Blue-Point®)

- Intended for heavy-duty applications, such as cutting large bolts and rivets, separating ball joints, cutting heavy-gauge sheet metal and driving bushings
- 3,400 BPM
- Quick-change chuck makes bit changing easy
- Variable-speed trigger with a built-in speed regulator
- Comfort grip handle for less user fatigue
- Hard-hitting; gets the job done quicker

AIR: DIE GRINDERS



PTGR100

PTGR105

PTGR110

PTGR115

PTGR200

PTGR205

PTGR210A

Mini and Standard Die Grinders, 1/4" Collet

Specifications	PTGR100*†	PTGR105†	PTGR110*†	PTGR115^	PTGR200*†	PTGR205*†	PTGR210A*†
Collet Size, inches	1/4	1/4	1/4	1/4	1/4	1/4	1/4
Rated Power, HP (kW)	1/3 (.2)	1/3 (.2)	1/3 (.2)	1/3 (.2)	.5 (.3)	.5 (.3)	.5 (.3)
Free Speed, RPM	25,000	25,000	25,000	25,000	23,000	23,000	23,000
Air Consumption, Free Speed, CFM (SCFM) [l/min]	1.7 (11) [48]	1.7 (11) [48]	1.7 (11) [48]	1.7 (11) [48]	3.2 (23) [90]	3.2 (23) [90]	3.2 (23) [90]
Air Inlet Thread Size, inches (NPT)	1/4 (18)	1/4 (18)	1/4 (18)	1/4 (18)	1/4 (18)	1/4 (18)	1/4 (18)
Recommended Hose Size, inches (mm)	3/8 (10)	3/8 (10)	3/8 (10)	3/8 (10)	3/8 (10)	3/8 (10)	3/8 (10)
Vibration Level, m/s ²	2.6	2.69	4.8	4.4	2	3	5.2
Sound Level dB(A) Pressure	83.3	82.4	85.9	84.5	85.1	85.9	86
Length, inches (mm)	6.1 (155)	9.8 (250)	5.75 (146)	9.5 (241)	6.9 (175)	10.9 (277)	6.4 (162)
Weight, lb (kg)	1 (0.4)	1.4 (.63)	1.2 (0.5)	2.1 (0.95)	1.2 (.5)	2.1 (0.95)	1.4 (.63)

Colors Available



* Red Green Hi-Viz
G HV
ADD SUFFIX TO STOCK NUMBER FOR SPECIAL COLORS.

†€ - DE, ES, FR, IT, GB, NL, JP

^€ - DE, ES, FR, IT, NL, JP

Heavy-Duty Die Grinders

- With more stall torque than any other Snap-on® Die Grinders, these Die Grinders are ergonomically designed and surprisingly lightweight for superior control, low vibration and less fatigue
- Featuring thermally balanced 1 HP motors that deliver 12,000 RPM–25,000 RPM of free speed power for maximum performance and high stall torque
- Provides the maneuverability to reach even the most restricted areas—and all the power ever needed

Specifications	PTGR400	PTGR405	PTGR410
Collet Size, inches	1/4	1/4	1/4
Rated Power, HP (kW)	1.0 (.6)	1.0 (.6)	1.0 (.6)
Free Speed, RPM	26,000	23,000	25,000
Air Consumption, Free Speed, CFM (SCFM) [l/min]	4.17 (30) [118]	4.17 (30) [118]	4.17 (30) [118]
Air Inlet Thread Size, inches (NPT)	1/4 (18)	1/4 (18)	1/4 (18)
Recommended Hose Size, inches (mm)	3/8 (10)	3/8 (10)	3/8 (10)
Vibration Level, m/s ²	2.1	3.25	.78
Sound Level dB(A) Pressure	84.7	82.2	86.2
Length, inches (mm)	7-1/2 (191)	12.25 (311)	7-1/2 (191)
Weight, lb (kg)	1.5 (.68)	2.6 (1.1)	1.5 (.68)

CE - DE, ES, FR, IT, GB, NL, JP

- PTGR400 1 HP Heavy-Duty Die Grinder**
- PTGR405 1 HP Heavy-Duty Long-Neck Die Grinder**
- PTGR410 1 HP Heavy-Duty Right Angle Die Grinder**

Colors Available



Red Green Hi-Viz
G HV
ADD SUFFIX TO STOCK NUMBER FOR SPECIAL COLORS.



PTGR400



PTGR405



PTGR410

AIR: DIE GRINDERS (Blue Point®)

Pencil, 1/8" Collet (Blue-Point®)

- Twist-action variable-speed control
- 5' (1.5 m) long protected air hose
- Used with 1/8" shank grinding accessories rated a minimum of 75,000 RPM
- Ideal for tight spaces and easy cleaning of dies, rotors and brake pads

Specifications	AT1070A	AT1070RA
Collet Size, inches (mm)	1/8 (3)	1/8 (3)
Free Speed, RPM	75,000	75,000
Air Consumption, Free Speed, CFM (SCFM) [l/min]	1 (7) [28]	1 (7) [28]
Air Inlet Thread Size, inches (NPT)	1/4 (18)	1/4 (18)
Recommended Hose Size, inches (mm)	3/8 (10)	3/8 (10)
Vibration Level, m/s ²	2.0	2.0
Sound Level dB(A) Pressure	72	72
Length, inches (mm)	5.3 (135)	5.9 (150)
Weight, lb (kg)	.55 (0.25)	.46 (0.21)

- AT1070A Pencil Die Grinder (Blue-Point®)**
- AT1070RA Right Angle Pencil Air Die Grinder (Blue-Point®)**



AT1070A



AT1070RA



- Do not use grinder accessories beyond their maximum rated RPM.
- Use air hammer accessories only for their intended purpose.
- Do not use chipped or damaged accessories.
- Read Safety Precautions on pages W1-W4

AIR: DIE GRINDERS (Blue Point®)



AT115



AT118



AT105



AT109



AT119



AT116



AT120L



AT120LRA



AT109DGK

1/4" Collet (Blue-Point®)

Specifications	AT115†	AT118†	AT105†	AT109*†	AT119†	AT116†	AT120L	AT120LRA
Collet Size, inches (mm)	1/4 (6)	1/4 (6)	1/4 (6)	1/4 (6)	1/4 (6)	1/4 (6)	1/4 (6)	1/4 (6)
Rated Power, HP (kW)	0.45 (.33)	0.2 (.15)	0.45 (.33)	0.2 (.15)	0.2 (.15)	0.2 (.15)	0.22 (.164)	0.45 (.335)
Free Speed, RPM	22,000	20,000	22,000	20,000	20,000	20,000	23,000	18,000
Air Consumption, Free Speed, CFM (SCFM) [l/min]	4 (29) [113]	4.0 (29) [113]	4 (29) [113]	2.1 (15) [59]	3 (15) [59]	3 (15) [59]	3 (22) [85]	3.3 (24) [93.4]
Air Inlet Thread Size, inches (NPT)	1/4 (18)	1/4 (18)	1/4 (18)	1/4 (18)	1/4 (18)	1/4 (18)	1/4 (18)	1/4 (18)
Recommended Hose Size, inches (mm)	3/8 (10)	3/8 (10)	3/8 (10) ID min.	3/8 (10)	3/8 (10)	3/8 (10)	3/8 (10)	3/8 (10)
Vibration Level, m/s ²	<2.5	2.5	<2.5	2.5	<6.92	3	1.83	1.83
Sound Level dB(A) Pressure	95	93	102	93	100	100	77	79
Length, inches (mm)	6.5 (165)	5.5 (140)	6.5 (165)	5.5 (140)	6.81 (173)	6.5 (165)	11.02 (280)	11.25 (285)
Weight, lb (kg)	1.3 (.61)	1.1 (.50)	1.3 (.61)	1.1 (.50)	1.1 (.50)	1.1 (.50)	1.45 (.66)	1.63 (.74)

*See below for AT109DGK Die Grinder Kit specifications.

†CE - DE, ES, FR, IT, GB, NL

AT115 Standard Air Die Grinder (Blue-Point®)

- Intended for most standard deburring operations
- Ergonomic handle grip increases comfort and control
- Safety lever throttle
- Built-in speed regulator
- Brass bearing cap and hose adaptor
- Rear diffused exhaust

AT118 90° Angle Mini Air Die Grinder (Blue-Point®)

- Cleans dies, rotors, backing plates and brake pad mounts
- Removes gasket material, grinds valve seats, dresses welds and enlarges holes
- Compact, mini design with 90° angled head for easy access
- Ergonomic handle grip for increased comfort and control
- Safety lever throttle
- Built-in speed regulator
- Brass bearing cap and hose adaptor

AT105 Standard Air Die Grinder (Blue-Point®)

- Aluminum housing for long-lasting durability
- Intended for most standard deburring operations
- High-quality bearings improve productivity with less repair
- Rear exhaust directs air away from work area

AT109 Right Angle Mini Air Die Grinder (Blue-Point®)

- Aluminum housing for long lasting durability
- Compact mini design with 90° head for easy access
- High-quality bearings improve productivity with less repair

AT109DGK Die Grinder Kit (Blue-Point®)

- Includes AT109 Mini Angle Die Grinder plus (1) 2" (50.8 mm) ROLOC® pad, (2) 2" (50.8 mm) coarse discs, (2) 2" (50.8 mm) medium discs, (2) 2" (50.8 mm) 24 grit discs, (2) 2" (50.8 mm) 36 grit discs, (2) 2" (50.8 mm) crud discs, (1) 3" (76.2 mm) ROLOC® pad, (2) 3" (76.2 mm) 50 grit discs, (2) 3" (76.2 mm) 120 grit discs, (2) 3" (76.2 mm) crud discs, (1) 1/4" shank adaptor and (2) spanner wrenches in a storage case

AT119 115° Angle Mini Air Die Grinder with 2" Quick Change Disc (Blue-Point®)

- 115° offset head for a more ergonomic grinding position
- Thread-on-style disc provides a more compact head
- Includes (1) 2" quick change disc so the tool is ready for an abrasive pad
- Ideal for body work spot sanding, cleaning gasket material from surfaces, dressing welds, and cleaning brake rotors, backing plates and brake pads

AT116 115° Angle Mini Air Die Grinder (Blue-Point®)

- 115° offset head provides a more ergonomic grinding position
- 1/4" collet
- Compact size ideal for accessing hard-to-reach areas
- Overmolded comfort grip
- Variable-speed regulator for precision control
- Available optional accessories include AT116-3 ROLOC® Pad (2", 1/4" shaft) and AT116-4 ROLOC® Pad (3", 1/4" shaft)
- Removes gasket material, grinds valve seats, dresses welds and enlarges holes

AT120L Extended-Length Mini Air Die Grinder (Blue-Point®)

- 4-1/2" of extended reach for greater accessibility
- Comfort grip reduces fatigue
- Built-in speed regulator matches tool speed to the job
- Safety throttle releases lever to shut off tool

AT120LRA Right Angle Extended-Length Mini Air Die Grinder (Blue-Point®)

- 4-1/2" of extended reach, with a 90° head
- Comfort grip reduces fatigue
- Built-in speed regulator matches tool speed to the job
- Safety throttle releases lever to shut off tool
- .45 HP motor with 18,000 RPM free speed

Heavy-Duty Die Grinders

Specifications	PTGR450
Length, inches (mm)	9.0 (228)
Rated Power, HP (kW)	1.0 (.6)
Weight, lb (kg)	3.25 (1.47)
Wheel Size, inches (mm)	4-1/2 (114)
Free Speed, RPM	12,000
Air Consumption, Free Speed, CFM (SCFM) [l/min]	4.17 (30) [118]
Air Inlet Thread Size, inches (NPT)	1/4 (18)
Recommended Hose Size, inches (mm)	3/8 (10)
Vibration Level, m/s ²	8.9
Sound Level dB(A) Pressure	86.3

CE - DE, ES, FR, IT, GB, NL, JP



PTGR450

Colors Available



Red Green Hi-Viz
R G HV

ADD SUFFIX TO STOCK NUMBER FOR SPECIAL COLORS.

PTGR450 4-1/2" 1 HP Heavy-Duty Angle Grinder

- Powerful, efficient, thermally balanced air motor cools internal components
- Adjustable rear exhaust directs airflow away from work area
- Built-in air regulator provides the ability to dial in the exact speed for a specific application
- Dual taper collet system improves bit retention
- Easy bit changing with standard wrenches
- Ergonomic comfort grip handle isolates vibration
- Variable-speed safety-style paddle trigger helps prevent accidental start-up
- Low vibration and sound levels help reduce user fatigue
- 12,000 RPM for maximum performance and stall torque
- Small size provides maneuverability in tight areas
- Lightweight for superior control with low vibration
- Improved safety lever makes engaging and operating the tool even easier
- Adjustable wheel guard

Grinder (Blue-Point®)

Specifications	AT215
Description	2" Angle Grinder (Blue-Point®)
Length, inches (mm)	7.4 (188)
Overall Length, inches (mm)	7.4 (188)
Disc Size, Dia., inches (mm)	2 (50.8)
Rated Power, HP (kW)	0.5 (.37)
Weight, lb (kg)	1.8 (.82)
Wheel Size, inches (mm)	2 (51)
Free Speed, RPM	15,000
Horsepower, HP	.5
Air Consumption, Free Speed, CFM (SCFM) [l/min]	3 (22) [85]
Air Inlet Thread Size, inches (NPT)	1/4 (18)
Recommended Hose Size, inches (mm)	3/8 (10)
Recommended Air Pressure, PSIG (kPa)	90 (620)
Vibration Level, m/s ²	<2.86
Sound Level dB(A) Pressure	73



AT215

AT215 2" Angle Grinder (Blue-Point®)

- Excellent for working in confined areas on jobs that require fast metal removal
- Ideal for body shops, automobile and truck repair
- Grease fitting in head enables gears to be greased for longer tool life
- Includes (6) 2" wheels; tool is ready for use
- Moveable guard—up to 50° in either direction—fits various applications
- Built-in speed regulator allows the user to set the desired speed, providing more control
- Rear exhaust with rotating deflector directs air away from the work area with no blowback toward the user
- Comfort grip housing insulates from cold and vibration for less user fatigue
- Safety lever throttle prevents accidental start-ups for increased safety
- Includes AT215GWSET six pack grinding stone



- Do not operate without the guard.
- Do not use grinding discs or accessories above their rated RPM.
- Read Safety Precautions on pages W1-W4

AIR: CUT-OFF TOOLS



PTC430



PTC490

Colors Available



Red Green Hi-Viz

PTC430 G HV

PTC490 — HV

ADD SUFFIX TO STOCK NUMBER FOR SPECIAL COLORS.

Heavy-Duty Cut-Off Tools

- Powerful thermally balanced air motor cools internal parts and the tool surface
- Double bearings for smooth operation
- Built-in speed regulator for easy adjustment
- Rear-diffused exhaust directs exhaust away from the work area
- Lightweight and ergonomic comfort grip handle for less user fatigue
- Paddle-style trigger/safety lever for easy operation
- Precision-machined steel end plates for greater durability
- Adjustable wheel guard for use at any angle

Specifications	PTC430	PTC490
Wheel Size, inches (mm)	3 (76)	4 (102)
Rated Power, HP (kW)	1.0 (.75)	1.0 (0.75)
Free Speed, RPM	25,000	12,000
Air Consumption, Free Speed, CFM (SCFM) [l/min]	4.17 (23) [90]	4.17 (23) [90]
Air Inlet Thread Size, inches (NPT)	1/4 (18)	1/4 (18)
Recommended Hose Size, inches (mm)	3/8 (10)	3/8 (10)
Vibration Level, m/s ²	6.92	3.41
Sound Level dB(A) Pressure	87	87.8
Length, inches (mm)	7-1/2 (191)	9.3 (236)
Weight, lb (kg)	1.9 (.86)	3 (1.3)
3" Cutter Wheels (36-Grit) (opt.)	AT150-20A	—
3" Cutter Wheels (54-Grit) (opt.)	AT150C29A	—
4" Cutter Wheels (opt.)	—	AT154RWHMP

CE - DE, ES, FR, IT, GB, NL, JP

PTC430 1 HP Heavy-Duty 3" Cut-Off Tool

- 25,000 RPM for maximum performance and stall torque
- Adjustable rear exhaust allows user to direct airflow away from work area
- Built-in air regulator allows user to dial in the exact speed required for the specific application
- Ergonomic comfort grip handle isolates vibration
- Variable-speed paddle-style safety trigger helps prevent accidental start-up
- Low vibration and sound levels help reduce fatigue and vibration
- Small size provides maneuverability in tight areas
- Lightweight for superior control
- Improved safety lever makes engaging and operating the tool even easier
- Ideal for many automotive and industrial cutting applications

PTC490 1 HP Heavy-Duty 4" Angle Cut-Off Tool

- 12,000 RPM for maximum performance and stall torque
- Use for heavy frame grinding, chamfering, welding cleanup and hardened steels



PTC250

Colors Available



Red Green Hi-Viz

R G HV

ADD SUFFIX TO STOCK NUMBER FOR SPECIAL COLORS.

Cut-Off Tool

Specifications	PTC250
Wheel Size, inches (mm)	3 (76)
Rated Power, HP (kW)	0.5 (.37)
Free Speed, RPM	23,000
Air Consumption, Free Speed, CFM (SCFM) [l/min]	3.2 (23) [90]
Air Inlet Thread Size, inches (NPT)	1/4 (18)
Vibration Level, m/s ²	6
Sound Level dB(A) Pressure	86.1
Length, inches (mm)	7.2 (183)
Weight, lb (kg)	1.6 (.73)
3" Cutter Wheels (36-Grit) (opt.)	AT150-20A
3" Cutter Wheels (54-Grit) (opt.)	AT150C29A

CE - DE, ES, FR, IT, GB, NL, JP

PTC250 1/2 HP 3" Cut-Off Tool

- 23,000 RPM for maximum performance and stall torque
- Adjustable cutting wheel guard rotates to any safe and convenient position
- Adjustable regulator matches tool speed to job requirements
- With wider wheels, the tool also makes an excellent weld grinder
- Powerful, efficient, thermally balanced air motor cools internal components and surface temperature of the tool
- Variable-speed paddle-style safety trigger helps prevent accidental start-up
- High-quality single-row bearings allow for smooth operation and minimal runout to keep the tool running longer
- Black Alcryn® grips for improved comfort and resistance to automotive fluids
- Easy wheel changing using standard wrenches
- Optional accessories include AT150-20A Cut-Off Wheel

Reversible Cut-Off Tools (Blue-Point®)

Specifications	AT154RA	AT157R
Wheel Size, inches (mm)	4 (102)	3 (76)
Rated Power, HP (kW)	0.7 (0.5)	0.45 (.33)
Free Speed, RPM	13,000	20,000
Air Consumption, Free Speed, CFM (SCFM) [l/min]	3.1 (22) [87]	3.5 (25) [99]
Air Inlet Thread Size, inches (NPT)	1/4 (18)	1/4 (18)
Recommended Hose Size, inches (mm)	3/8 (10)	3/8 (10)
Cutter Wheel Dia., inches	—	3
Vibration Level, m/s ²	3.07	<3.8
Sound Level dB(A) Pressure	85	100
Length, inches (mm)	14.3 (365)	7.3 (185)
Weight, lb (kg)	3.3 (1.5)	1.9 (.86)
3" Cutter Wheels (36-Grit) (opt.)	—	AT150-20A
3" Cutter Wheels (54-Grit) (opt.)	—	AT150C29A
4" Cutter Wheels	AT154RWHLMP	—



AT154RA



AT157R

AT154RA 4" Reversible Cut-Off Tool (Blue-Point®)

- 14.3" overall length provides extended reach for easier access
- Reverse mode controls direction of sparks for safety
- Exhaust is diffused through the rear of the tool away from work surface
- Side handle provides additional tool control

AT157R 3" Reversible Cut-Off Tool (Blue-Point®)

- Ideal for use in body shops and other general automotive applications
- Spark direction control
- Extended reach for hard-to-access areas
- Built-in speed regulator for fine tuning
- Safety throttle lever
- Comfort grip handle
- Uses wheels only rated above 18,000 RPM
- Recommended for cutting mufflers, hose clamps, bolts and sheet metal
- 1 year limited warranty

AIR: CUT-OFF TOOLS (Blue-Point®)

Cut-Off Tool (Blue-Point®)

Specifications	AT153
Wheel Size, inches (mm)	3 (76)
Rated Power, HP (kW)	0.5 (0.37)
Free Speed, RPM	17,000
Air Consumption, Free Speed, CFM (SCFM) [l/min]	3.5 (24) [99.1]
Air Inlet Thread Size, inches (NPT)	1/4 (18)
Recommended Air Pressure, PSIG (kPa)	90 (620)
Recommended Hose Size, inches (mm)	3/8 (10)
Vibration Level, m/s ²	<2.86
Sound Level dB(A) Pressure	85
Length, inches (mm)	7.3 (185)
Weight, lb (kg)	3.3 (1.5)
3" Cutter Wheels (36-Grit) (opt.)	AT150-20A
3" Cutter Wheels (54-Grit) (opt.)	AT150C28A

CE - DE, ES, FR, IT, GB, NL

AT153 Cut-Off Tool (3") (Blue-Point®)

- Compact size is excellent for accessing areas with limited working space
- Heavy-duty bevel gears for tool longevity
- Indexing adjustable guard controls the direction of sparks
- Spindle lock eliminates the need for special wrenches for fast change of cut-off wheels
- Adjustable built-in regulator easily adjusts up to 17,000 RPM free speed



AT153



- Do not operate without the guard.
- Do not use grinding discs or accessories above their rated RPM.
- Read Safety Precautions on pages W1-W4

AIR: CUTTING TOOLS (Blue-Point®)



AT195

Shears (Blue-Point®)

Specifications	AT195
Air Consumption, Free Speed, CFM (SCFM) [l/min]	4.0 (29) [113]
Air Inlet Thread Size, inches (NPT)	1/4 (18)
Recommended Hose Size, inches (mm)	3/8 (10)
Vibration Level, m/s ²	<2.5
Sound Level dB(A) Pressure	99.6
Length, inches (mm)	10 (254)
Weight, lb (kg)	2.8 (1.3)

AT195 Air Powered Shears (Blue-Point®)

- Pistol grip handle for comfort and accessibility
- Handle exhaust is directed away from the operator
- Ball bearing-mounted rotary air motor for long service
- Lightweight aluminum housing is durable and helps to reduce fatigue
- Built-in speed regulator provides torque control
- Variable-speed trigger for maximum control
- Removable brass filter captures dirt and grit that could clog and damage the impact mechanism
- Replacement blades: Left blade (AT195-37), center blade (AT195-39B) and right blade (AT195-40B)



AT180C

Nibbler (Blue-Point®)

Specifications	AT180C
Free Speed, RPM	3,500
Air Consumption, Free Speed, CFM (SCFM) [l/min]	4 (29) [113]
Air Inlet Thread Size, inches (NPT)	1/4 (18)
Recommended Hose Size, inches (mm)	3/8 (10)
Vibration Level, m/s ²	4.3
Sound Level dB(A) Pressure	97
Length, inches (mm)	7.6 (193)
Weight, lb (kg)	1.9 (.88)

AT180C Nibbler (Blue-Point®)

- Cuts mild steel sheet up to 16-gauge (0.62") (1.55 mm)
- Anvil is adjustable for forward, backward, and left or right cutting; enabling the nibbler to make sheet metal cuts of any configuration
- Readily cuts most non-ferrous materials including aluminum, brass, formica, laminates, fiberglass and masonite
- Includes Standard Punch (AT180B-10)
- Replacement Pouch: AT180C-38

AIR: RECIPROCATING SAWS



PTRS1000

Air Saw

Stock No.	Free Speed, SPM	Air Consumption, Free Speed, CFM (SCFM) [l/min]	Air Inlet Thread Size, inches (NPT)	Vibration Level, m/s ²	Sound Pressure Level, dB(A)	Length, inches (mm)	Weight, lb (kg)
PTRS1000	9,000	2.4 (15)	1/4 (18)	10.0	87.2	8.5 (215)	1.6 (0.73)

CE - DE, ES, FR, IT, GB, NL, JP

PTRS1000 Heavy-Duty Reciprocating Air Saw

- Dual chuck accepts standard air saw blades and saber saw blades
- Able to cut 1/8"-thick (3 mm) mild steel with smooth cutting action
- Comfort cushion grip reduces vibration for less user fatigue
- Variable-speed paddle-style safety trigger helps prevent accidental start-up

- Improved motor performance and durability over previous models
- Improved airflow increases cutting capacity by 30%
- Air exhausts out the front of tool, cooling the blade and clearing the work area
- Includes (3) air saw blades

Colors Available



ADD SUFFIX TO STOCK NUMBER FOR SPECIAL COLORS.



AT192A



AT194A

Reciprocating Saws (Blue-Point®)

Stock No.	Free Speed, RPM	Air Consumption, Free Speed, CFM (SCFM) [l/min]	Air Inlet Thread Size, inches (NPT)	Recommended Hose Size, inches (mm)	Vibration Level, m/s ²	Sound Level dB(A) Pressure	Length, inches (mm)	Weight, lb (kg)
AT192A	11,000	1.0 (7) [28]	1/4 (18)	3/8 (10)	10.1	94	9.3 (235)	1.75 (0.80)
AT194A	8,250	0.7 (5) [20]	1/4 (18)	3/8 (10)	<6.6	87	6.7 (170)	1 (0.45)

AT192A High-Speed Reciprocating Saw (Blue-Point®)

- Adjustable blade guard controls cutting depth
- Teflon®-coated piston for smooth operation and durability
- Features a comfort grip handle with a safety lever throttle
- Includes saw and (3) blades (18, 24 and 32 TPI)
- Performs straight or scroll cuts in metal and plastic
- Comfort grip housing for greater control
- Optional 4" long blades are also available

AT194A Micro Air Saw (Blue-Point®)

- Compact size for easy access in tight quarters
- Guarded hose extension helps prevent damage to finished surfaces
- Performs straight or scroll cuts in metal and plastic
- Includes bi-metal blades: (1) 18 TPI, (1) 24 TPI, (1) 32 TPI



PSO4512



PSO4612



PSO4625



PSO4525



PSO4612V



PSO4625V

Orbital and Geared Sanders

Specifications	PSO4512	PSO4525	PSO4612	PSO4612V	PSO4625	PSO4625V
Pad/Disc Size, Dia., inches (mm)	5 (127)	5 (127)	6 (152)	6 (152)	6 (152)	6 (152)
Style	Orbital	Orbital	Orbital	Orbital	Orbital	Orbital
Pattern, inches	3/16	3/16	3/16	3/16	3/16	3/16
Rated Power, HP (kW)	.25/(.19)	.25 (.19)	.25/(.19)	.25/(.19)	.25 (.19)	.25 (.19)
Free Speed RPM	12,000	12,000	12,000	12,000	12,000	12,000
Spindle Thread, inches	5/16"-24	1/4"-20	1/4"-20	1/4"-20	1/4"-20	1/4"-20
Air Consumption, Free Speed, CFM (SCFM) [l/min]	2 (14) [57]	2 (14) [57]	2 (14) [57]	2 (14) [57]	2 (14) [57]	2 (14) [57]
Air Inlet Thread Size, inches (NPT)	1/4 (18)	1/4 (18)	1/4 (18)	1/4 (18)	1/4 (18)	1/4 (18)
Recommended Hose Size, inches (mm)	3/8 (10)	3/8 (10)	3/8 (10)	3/8 (10)	3/8 (10)	3/8 (10)
Vibration Level, m/s ²	2.1	2.3	2.1	2.1	2.3	2.3
Sound Level dB(A) Pressure	74.9	75.3	74.9	74.9	75.3	75.3
Length, inches (mm)	6 (152)	6 (152)	6.5 (165)	6.5 (165)	6.5 (165)	6.5 (165)
Weight, lb (kg)	1.8 (.82)	1.8 (.82)	1.8 (.82)	1.8 (.82)	1.8 (.82)	1.8 (.82)

PSO4512 5" Orbital Sander, 3/16" Pattern PSA Pad

- Low vibration sander for better performance and less user fatigue
- Kevlar Vanes last longer and help reduce moisture and oil on the work area
- O-ring sealed motor keeps dust and debris from entering critical components
- Field replaceable motor allows for motor replacement on the spot
- Powerful .25 HP motor generates 12,000 RPM for plenty of power
- Precision balanced crank and robust spindle provide a smooth operation with minimal vibration
- Adjustable top grip allow the end user to customize the position to their preferred setting
- Multiposition speed regular lets you dial in the precise speed for each application
- Ergonomic "S"-shaped paddle fits the hand better than flat levers
- PSA pad for easy abrasive changes

PSO4612 6" Orbital Sander, 3/16" Pattern PSA Pad

PSO4612V 6" Orbital Sander, 3/16" Pattern

- Includes vacuum port for dust control

PSO4525 5" Orbital Sander with 3/16" Pattern

PSO4625 6" Orbital Sander with 3/16" Pattern

- Powerful 1/4 HP motor generates 12,000 RPM
- For sanding various surfaces including painted and metal applications
- Field replaceable motor

PSO4625V 6" Orbital Sander with 3/16" Pattern

- Lightweight, sanding pads are flexible for spot sanding and surface preparation from body fillers to paint primer

Colors Available



ADD SUFFIX TO STOCK NUMBER FOR SPECIAL COLORS.



- Do not use sanding discs or accessories above their maximum rated RPM.
- Do not use grinding discs on sanders.
- Wear protective gloves.
- Read Safety Precautions on pages W1-W4

AIR: SANDERS



PSDF4600



PSDF4600V



PSOF4312



PSOF4612

Colors Available



ADD SUFFIX TO STOCK NUMBER FOR SPECIAL COLORS.

Orbital and Geared Sanders

Specifications	PSDF4600	PSDF4600V	PSOF4312	PSOF4612
Pad/Disc Size, Dia., inches (mm)	6 (152)	6 (152)	3 (76)	6 (152)
Pattern	3/16 Orbit	3/16 Orbit	—	—
Pattern, inches	—	—	3/32	3/32
Style	Dual-Function	Dual-Function	Orbital	Orbital
Rated Power, HP (kW)	0.45	0.45	.25/(.19)	.25/(.19)
Free Speed, RPM	1,200	1,200	12,000	12,000
Spindle Thread, inches	3/8	3/8	5/16"-24	5/16"-24
Air Consumption, Free Speed, CFM (SCFM) [l/min]	3 (22) [85]	3 (22) [85]	2 (14) [57]	2 (14) [57]
Air Inlet Thread Size, inches (NPT)	1/4 (18)	1/4 (18)	1/4 (18)	1/4 (18)
Recommended Air Pressure, PSIG (kPa)	90 (620)	90 (620)	90 (620)	90 (620)
Recommended Hose Size, inches (mm)	3/8 (10)	3/8 (10)	3/8" (10)	3/8" (10)
Vibration Level, m/s ²	4.7	4.7	2.1	2.1
Sound Level dB(A) Pressure	79	79	74.9	74.9
Length, inches (mm)	11 (279)	11 (279)	6 (152)	6 (152)
Weight, lb (kg)	3.7 (170)	3.7 (170)	1.7 (.77)	1.7 (.77)
Pad Type	—	—	PSA	PSA
Replacement Pad/Disc	PSDF4600-58	PSDF4600-58	PSO4612-2	PSO4612-2

CE

PSDF4600 6" Dual-Function Sander

- Large dial to change from random orbit to rotary disc operation saves time
- Features Kevlar® vanes for longer life
- Premium hook-and-loop pad for durability
- Quickly removes coatings prior to painting
- For use on metal, solid surfaces, wood and fiberglass
- Ergonomic grip for comfort
- Soft grip housing material for maximum vibration absorption
- Powerful 1/2 HP motor generates 1,200 RPM for removing large amounts of filler material and leveling small welds

PSDF4600V 6" Dual-Function Sander with Vacuum

- Includes vacuum attachment for a cleaner workspace

PSOF4312 3" Orbital Finishing Sander, 3/32" Pattern

PSOF4612 6" Orbital Finishing Sander, 3/32" Pattern

- Low vibration sander for better performance and less user fatigue
- Kevlar® vanes last longer and help reduce moisture and oil on the work area
- O-ring sealed motor keeps dust and debris from entering critical components
- Field replaceable motor allows for motor replacement on the spot
- Powerful .25 HP motor generates 12,000 RPM for plenty of power
- Precision balanced crank and robust spindle provide a smooth operation with minimal vibration
- Adjustable top grip allow the end user to customize the position to their preferred setting
- Multiposition speed regular lets you dial in the precise speed for each application
- Ergonomic "S"-shaped paddle fits the hand better than flat levers
- PSA pad for easy abrasive changes



PTBF210

Belt Sanders

Specifications	PTBF210
Air Consumption, Free Speed, CFM (SCFM)	3.2 (23)
Air Inlet Thread Size, inches (NPT)	1/4 (18)
Belt Size	1/4-3/4" W x 18" L
Exhaust Type	Rear
Free Speed, r/min	18,000
Horsepower, HP	0.5
Length, inches (mm)	14.5 (386)
Recommended Hose Size, inches (mm)	3/8 (10)
Trigger Style	Paddle
Weight, lb (kg)	2.9 (1.3)
Width, inches (mm)	4.5 (114)

PTBF210 Band Sander

- Powerful, efficient, thermally balanced air motor cools internal components and surface temperature of the tool
- Adjustable rear exhaust allows user to direct airflow away from work area
- 90° angle head to improve access
- Accepts 18" belts
- Head can be rotated 270° for flexibility without tools
- Built-in 10-position air regulator provides the ability to dial in exact speed for a specific application
- Ergonomic comfort grip handle isolates vibration
- Variable-speed safety-style paddle trigger helps prevent accidental start-up
- Low vibration and sound levels help reduce user fatigue
- Industrial-grade gears and motor provide a longer lasting tool
- Tool-free adjustable belt build and cover for easy belt changes
- Standard side support handle for tool control



PSG4609V



PSG4645



PSG4845



PSG4809



PSG4609V



PSG4645V



PSG4845V

Colors Available



Red Green Hi-Viz

R G HV

ADD SUFFIX TO STOCK NUMBER FOR SPECIAL COLORS.

Orbital and Geared Sanders

Specifications	PSG4609	PSG4609V	PSG4645	PSG4645V	PSG4845	PSG4845V	PSG4809
Pad/Disc Size, Dia., inches (mm)	6 (152)	6 (152)	6 (152)	6 (152)	8 (203)	8 (203)	8 (203)
Style	Geared (NV)	Geared (V)	Geared (NV)	Geared (NV)	Geared (NV)	Geared (NV)	Geared (NV)
Pattern	5 mm Epicycloidal	5 mm Epicycloidal	5 mm Epicycloidal	5 mm Epicycloidal	5 mm Epicycloidal	5 mm Epicycloidal	—
Rated Power, HP (kW)	0.42 (.33)	0.42 (.33)	0.42 (.33)	0.42 (.33)	0.42 (.33)	0.42 (.33)	0.42 (.33)
Free Speed, RPM	1,000	1,000	1,000	1,000	1,000	1,000	1,000
Spindle Thread, inches	3/8	3/8	3/8	3/8	3/8	3/8	3/8
Air Consumption, Free Speed, CFM (SCFM) [l/min]	3 (21.7) [85]	3 (21.7) [85]	3 (21.7) [85]	3 (21.7) [85]	3 (21.7) [85]	3 (21.7) [85]	3 (21.7) [85]
Air Inlet Thread Size, inches (NPT)	1/4 (18)	1/4 (18)	1/4 (18)	1/4 (18)	1/4 (18)	1/4 (18)	1/4 (18)
Recommended Hose Size, inches (mm)	3/8 (10)	3/8 (10)	3/8 (10)	3/8 (10)	3/8 (10)	3/8 (10)	3/8 (10)
Vibration Level, m/s ²	5.9	5.9	5.9	5.9	5.9	5.9	5.9
Sound Level dB(A) Pressure	80	80	80	80	80	80	80
Sound Level, Free Speed, dB(A)	82	82	82	82	82	82	82
Length, inches (mm)	11 (279)	11 (279)	11 (279)	11 (279)	11 (279)	11 (279)	11 (279)
Weight, lb (kg)	3.7 (1.70)	3.7 (1.70)	3.7 (1.70)	3.7 (1.70)	4 (1.82)	4 (1.82)	4 (1.82)
Replacement Pad/Disc	PS468-34	PS468-34V	PS468-34HL	PS468-34HL	PS468-35HL	PS468-35HL	PS468-35
Pad (VELCRO®/optional)	PS468-34HL	PS468-34HL	—	—	—	—	PS468-35HL

CE

PSG4609 6" Geared Sander

- Patented dust shield keeps dirt and dust out of motor for longer tool life
- Ergonomic adjustable handle adjusts to fit users hand for more comfort
- Robust front spindle and balanced crank help reduced vibration while sanding for less user fatigue
- Eight vane steel rotor provides more power for tough jobs
- Steel cut gears provide better durability for less wear and tear
- One piece lightweight housing with soft grip material for comfort and maximum vibration absorption
- Ergonomic throttle lever and built-in speed regulator for consistent performance
- Includes Non-vacuum PSA pad
- VELCRO® pad is optional
- Soft grip housing material for maximum vibration absorption
- Optional vacuum models (PS4609V and PS4809V) also available

PSG4609V Geared Sander with Vacuum

PSG4645 6" Geared Sander

- Removes and levels large amounts of filler materials such as glue or epoxy
- Levels small welds
- Removes coatings prior to painting
- For use on metal, solid surfaces, wood and fiberglass
- Super-ergonomic adjustable grip is indexable to multiple positions for optimum comfort
- Soft grip housing material for maximum vibration absorption
- Optional vacuum model (PSOG4645V) also available

PSG4645V 6" Geared Sander with Vacuum

PSG4845 8" Geared Sander

PSG4845V 8" Geared Sander with Vacuum

PSG4809 8" Geared Sander with PSA Pad



- Do not use sanding discs or accessories above their maximum rated RPM.
- Do not use grinding discs on sanders.
- Read Safety Precautions on pages W1-W4

AIR: FINISHING TOOLS (Blue-Point®)



AT425R

Reversible Disc Sander (Blue-Point®)

Specifications	AT425R
Pad/Disc Size, Dia., inches (mm)	5 (127)
Rated Power, HP (kW)	0.45 (.33)
Free Speed, RPM	13,000
Spindle Thread, inches	7/16"-20 UNC
Air Consumption, Free Speed, CFM (SCFM) [l/min]	4.3 (31) [122]
Air Inlet Thread Size, inches (NPT)	1/4 (18)
Recommended Hose Size, inches (mm)	3/8 (10)
Vibration Level, m/s ²	<0.8
Sound Level dB(A) Pressure	93
Length, inches (mm)	5.3 (135)
Weight, lb (kg)	2.8 (1.28)
Replacement Pad/Disc	AT425R-24
3" Replacement Pad (opt.)	AT425R-22
4" Replacement Pad (opt.)	AT425R-23

AT425R 5" Reversible High-Speed Sander (Blue-Point®)

- Used in body shops and other general automotive applications
- Comfort grip handle
- Built-in speed regulator
- One-handed forward/reverse lever
- Includes (3) backing discs: 3, 4 and 5"



AT406C

Orbital Sanders (Blue-Point®)

Specifications	AT406C
Pad/Disc Size, Dia., inches (mm)	6 (152)
Rated Power, HP (kW)	.25 (.19)
Free Speed, RPM	12,000
Spindle Thread, inches	5/16"-24
Air Consumption, Free Speed, CFM (SCFM) [l/min]	2.5 (18) [71]
Vibration Level, m/s ²	2.8
Sound Level dB(A) Pressure	85
Length, inches (mm)	8.6 (219)
Weight, lb (kg)	1.5 (0.7)

AT406C 6" Orbital Palm Sander (Blue-Point®)

- Lightweight and durable composite housing
- Built-in power regulator for optimized power control
- Well-balanced for smooth handling
- For use with accessories rated above 12,000 RPM



AT408



AT411A

Dual-Action and Geared Sanders (Blue-Point®)

Specifications	AT408	AT411A
Pad/Disc Size, Dia., inches (mm)	8 (203)	6 (152)
Rated Power, HP (kW)	0.5 (.37)	0.5 (.37)
Free Speed, RPM	850	10,000
Spindle Thread, inches	5/16"-24	5/16"-18 UNC
Air Consumption, Free Speed, CFM (SCFM) [l/min]	5 (36) [142]	5 (36) [142]
Air Inlet Thread Size, inches (NPT)	1/4 (18)	1/4 (18)
Recommended Hose Size, inches (mm)	3/8 (10)	3/8 (10) ID min.
Vibration Level, m/s ²	3.7	3.7
Sound Level dB(A) Pressure	87	79
Length, inches (mm)	11 (279)	8 (203)
Weight, lb (kg)	4.8 (2.18)	4.7 (2.14)
Replacement Pad/Disc	AT408-2	AT411A-1

AT408 8" Geared Sander (Blue-Point®)

- Rear diffused exhaust
- Built-in adjustable-speed regulator
- Removable brass filter screens out debris

AT411A 6" Dual-Action Sander (Blue-Point®)

- Used for fine sanding operations and swirl-free finishing
- Comfort handle helps reduce fatigue
- Converts from rotary to random orbit action by sliding drive plate
- Built-in thumb-wheel speed regulator



AT475A

Inline Sander (Blue-Point®)

Specifications	AT475A
Pad/Disc Size, inches (mm)	2-3/4 x 17-1/2 (69.85 x 444.5)
Free Speed, RPM	1,800
Air Consumption, Free Speed, CFM (SCFM) [l/min]	2.3 (17) [65]
Air Inlet Thread Size, inches (NPT)	1/4 (18)
Recommended Hose Size, inches (mm)	3/8 (10) ID min.
Vibration Level, m/s ²	14.9
Sound Level dB(A) Pressure	87
Length, inches (mm)	16 (406)
Weight, lb (kg)	6.8 (3.09)
Replacement Pad/Disc	AT475A-29

AT475A 16" Heavy-Duty Inline Sander (Blue-Point®)

- 5/8" stroke
- Minimal vibration
- Used for fast material removal
- Pad has positive locking clamps

Sanding Belts

Stock No.	Type	Size	Grit	Package Quantity
ATBA1218120	Coated Abrasive	1/2 x 18"	120	5 Each
ATBA121860	Coated Abrasive	1/2 x 18"	60	5 Each
ATBA121880	Coated Abrasive	1/2 x 18"	80	5 Each
ATBA3418120	Coated Abrasive	3/4 x 18"	120	5 Each
ATBA341860	Coated Abrasive	3/4 x 18"	60	5 Each
ATBA341880	Coated Abrasive	3/4 x 18"	80	5 Each
ATBA3818120	Coated Abrasive	3/8 x 18"	120	5 Each
ATBA381860	Coated Abrasive	3/8 x 18"	60	5 Each
ATBA381880	Coated Abrasive	3/8 x 18"	80	5 Each
ATBB1218100	Non-Woven Abrasive	1/2 x 18"	100	5 Each
ATBB1218240	Non-Woven Abrasive	1/2 x 18"	240	5 Each
ATBB121850	Non-Woven Abrasive	1/2 x 18"	50	5 Each
ATBB3418100	Non-Woven Abrasive	3/4 x 18"	100	5 Each
ATBB3418240	Non-Woven Abrasive	3/4 x 18"	240	5 Each
ATBB341850	Non-Woven Abrasive	3/4 x 18"	50	5 Each
ATBB3818100	Non-Woven Abrasive	3/8 x 18"	100	5 Each
ATBB3818240	Non-Woven Abrasive	3/8 x 18"	240	5 Each
ATBB381850	Non-Woven Abrasive	3/8 x 18"	50	5 Each



ATBA1218120



AT615K

AT615K Belt Sander Kit

- Includes belt sander, (3) 18 x 3/8" sanding belts (60-, 80-, 120-grit), (3) 18 x 1/2" sanding belts (60-, 80-, 120-grit) and (3) 18 x 3/4" sanding belts (60-, 80-, 120-grit)

AT615-31 Collet Assembly (1/4")

- Optional 1/4" collet assembly for use with the AT615 Belt Sander

AT615ARM1 Contact Arm Assembly (1" D x 3/8" W; rubber)

- Used with the AT615 Belt Sander

AT615ARM2 Contact Arm Assembly (3/4" D x 3/8" W; rubber)

- Used with the AT615 Belt Sander

AT615ARM3 Contact Arm Assembly (3/4" D x 5/8" W)

- Used with the AT615 Belt Sander

Polishers (Blue-Point®)

Specifications	AT450DP
Style	Vertical Polisher
Pad Size, inches (mm)	7 (177)
Rated Power, HP	0.7
Free Speed, RPM	2,500
Spindle Thread Range, inches	5/8-11
Air Consumption CFM	3.6
Air Inlet Thread Size, inches (NPT)	1/4 (18)
Recommended Air Pressure, PSI	90
Vibration Level m/s ²	9
Sound Level, dB(A)	108
Length, inches (mm)	16 (406)
Weight, lb (kg)	4.95 (2.25)

CE - DE, ES, FR, IT, GB, NL

AT450DP 7" Heavy-Duty Vertical Polisher (Blue-Point®)

- Powerful air motor is ideal for sanding and polishing
- Variable-speed throttle for use on a variety of surfaces
- Dual side-handle mounts for optimal control
- Handle grips for increased comfort



AT450DP



- Do not overload.
- Do not use sanding discs or accessories above their maximum rated RPM.
- Read Safety Precautions on pages W1-W4

AIR: FINISHING TOOLS (Blue-Point®)



AT187

Engraving Pens (Blue-Point®)

AT187 Engraving Pen (Blue-Point®)

- Marks tools and other objects to prevent theft
- Used on hardened-steel plate (up to HRC55), metals, glass, stone, ceramic, plastics and more
- Used for deburring operations and reshaping screw/bolt heads for removal
- Rugged metal housing
- Knurled fingertip control
- Tips sold separately

AT187-11 45° Thick Plate Carbide Tip (Blue-Point®)

- For AT187

AT187-13 15° Thin Plate Carbide Tip (Blue-Point®)

- For AT187

AT187-14 30° Medium Plate Carbide Tip (Blue-Point®)

- For AT187



AT401MCA



AT402MCA



AT403MCA

Micro Sander and Polisher Kits (Blue-Point®)

Specifications	AT401MCA	AT402MCA	AT403MCA
Style	Micro Surface Prep	Micro Sander	Micro Polisher
Pad/Disc Size, Dia., inches (mm)	3 (76)	3 (76)	3 (76)
Rated Power, HP (kW)	0.25 (.19)	0.25 (.19)	0.25 (.19)
Free Speed, RPM	15,000	15,000	6,000
Spindle Thread, inches	1/4"-20	5/16"-24 UNF	5/16"-24 UNF
Air Consumption, Free Speed, CFM (SCFM) [l/min]	2.1 (15) [59]	2.1 (15) [59]	2.2 (16) [62]
Air Inlet Thread Size, inches (NPT)	1/4 (18)	1/4 (18)	1/4 (18)
Recommended Hose Size, inches (mm)	3/8 (10)	3/8 (10)	3/8 (10)
Vibration Level, m/s ²	<2.5	<2.5	<2.5
Sound Level dB(A) Pressure	84	84	86
Length, inches (mm)	4.7 (119)	5.2 (133)	5.6 (143)
Weight, lb (kg)	0.97 (0.44)	1.1 (0.50)	1.3 (0.60)

AT401MCA/AT402MCA/AT403MCA Micro Series (Blue-Point®)

- Powerful direct drive gear train for greater durability
- Large two-finger trigger for better control
- High-quality bearings for longer tool life
- Composite housing with comfort grip insulates from the cold
- Bottom handle diffused exhaust
- Variable-speed trigger

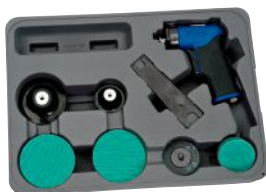

AT401MCKA

AT401MCKA Micro Surface Prep Tool Kit (Blue-Point®)

- Includes AT401MCA Micro Surface Prep Tool, (1) 2" ROLOC® pad, (1) 3" ROLOC® pad, (5) 2" 40 grit pads and (5) 3" 80 grit pads in a storage case



AT402MCKA

AT402MCKA Micro Dual-Action Sander Kit (Blue-Point®)

- Includes AT402MCA Micro Sander, (1) 3" Hookit® pad, (25) 3" 180 grit pads, (25) 3" 200 grit pads, (10) 3" 320 grit pads and (10) 3" 800 grit pads in a storage case



AT403MCKA

AT403MCKA Micro Polisher Kit (Blue-Point®)

- Includes AT403MCA Micro Polisher, (1) 3" Hookit® pad, (1) 3" wool pad, and (1) 3" foam pad in a storage case

Tire Buffer

AT240 Tire Buffer (Blue-Point®)

- Used for tire patch preparation, roughing up rubber for tire recaps plus removing excess rubber
- Speed regulator for improved tool control
- Comfort grip housing for reduced operator fatigue
- Rear exhaust directs air away from the work
- Semicircle buffing wheel for maximum surface preparation



AT240

Pinstripe Removal Tool

AT265A Pinstripe Removal Tool (Blue-Point®)

- Use to remove pinstripes, adhesive, tape and graffiti
- Includes (3) 3-1/2" eraser pads to keep you working longer
- Eraser-design step-pad for improved visibility during operation
- Comfort grip handle for less fatigue
- Auxiliary side handle for improved tool control



AT265A

AT265E Eraser



AT1212A

Needle Scaler

Stock No.	Type	Rated Power, HP (kW)	Free Speed, RPM	Air Consumption, Free Speed, CFM (SCFM) [l/min]	Air Inlet Thread Size, inches (NPT)	Vibration Level, m/s ²	Sound Level dB(A) Pressure	Length, inches (mm)	Weight, lb (kg)	Recommended Hose Size, inches (mm)
AT240	Buffer	0.4 (.298)	2,600	3.7 (26.6) [104.7]	1/4 (18)	1.18	89	9.1 (233)	1.8 (.82)	3/8 (10)
AT265A	Material Remover	0.4 (.298)	3,600	3.7 (26.6) [104.7]	1/4 (18)	0.69	88	8.1 (206)	1.8 (.82)	3/8 (10)
AT1212A	Scaler	—	4,000 BPM	4.0 (11.19) [113]	1/4 (18)	11.4	90	12.5 (318)	2.64 (1.20)	3/8 (10)

AT1212A Mini Needle Scaler (Blue-Point®)

- Mini size for access in confined areas
- (12) high-tension steel needles conform to any irregular surface for cleaning crevices
- Smooth palm-controlled trigger mechanism for ease of operation

AT1212A-16 Needles (12 pk)



- Use only accessories intended for each tool.
- Do not use accessories above their maximum recommended RPM.
- Read Safety Precautions on pages W1-W4

AIR: FINISHING TOOLS



PTGR280

Colors Available



ADD SUFFIX TO STOCK NUMBER FOR SPECIAL COLORS.

Remove-All Tool

Specifications	PTGR280
Style	Material Removal Tool
Rated Power, HP (kW)	0.45 (.33)
Free Speed, RPM	3,500
Air Consumption, Free Speed, CFM (SCFM) [l/min]	4 (28) [113]
Air Inlet Thread Size, inches (NPT)	1/4 (18)
Recommended Hose Size, inches (mm)	3/8 (10)
Vibration Level, m/s ²	2.8
Sound Level, dB(A)	85
Length, inches (mm)	12 (304)
Weight, lb (kg)	2.4 (1.09)
Rubber Eraser Wheel (opt.)	PT280303MP3

CE - DE, ES, FR, IT, GB, NL, JP

PTGR280 Crud Thug® Removal Air Tool

- Quickly removes seam sealers, rust, paint and underbody coatings
- Optional rubber eraser wheel for removing pinstripes and graphics
- Easily removes automotive crud without fumes, heat buildup or surface damage
- Includes (1) fine wire wheel and (1) coarse wire wheel
- Thermally balanced air motor routes air between the housing and liner for cooler tool temperatures and longer life
- Planetary gear system for increased torque
- Ergonomic cushion grip insulates against cold and vibration
- Adjustable rear exhaust allows user to direct airflow away from work area
- 10-position power/speed regulator allows easy RPM adjustment
- Paddle-style trigger for precise speed control



SPPT280-300



PT280-300-11



PT280-301-11



PT280-302-11



PT280-302MP5



PT280-304-11

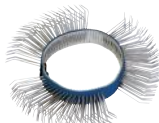

PT280-305-11



PT280-305-23



PT280-306-11



PT280-306-23

Remove-All Tool Accessory Belts

Stock No.	Description	Maximum Safe Free Speed, RPM	Wheel Diameter, inches (mm)	Width, inches (mm)	Wire Style
SPPT280-300	Wheel Hub Set	4,000	4 (102)	9/10 and 1-1/5 (23 and 30)	—
PT280-300-11	Hub	4,000	4 (102)	.4 (10)	—
PT280-301-11	Wire Wheel (Coarse)	4,000	4 (102)	.4 (10)	Bent, sharpened spring steel tips
PT280-301-23	Wire Wheel (Coarse)	4,000	4 (102)	23 (584)	Bent, sharpened spring steel tips
PT280-301MP5	Wire Wheel (Coarse)	4,000	4 (102)	23 (584)	Bent, sharpened hardened spring steel tips
PT280-302-11	Wire Wheel (Fine)	4,000	4 (102)	.4 (10)	Straight, hardened spring steel tips
PT280-302-23	Wire Wheel (Fine)	4,000	4 (102)	23 (584)	Straight, hardened spring steel tips
PT280-302MP5	Wire Wheel (Fine)	4,000	4 (102)	23 (584)	Straight, hardened spring steel tips
PT280-303-30	Rubber Eraser Wheel	3,500	4.13 (104.9)	30 (762)	Rubber Eraser
PT280-303MP3	Rubber Eraser Wheel	3,500	4.13 (104.9)	30 (762)	Rubber Eraser
PT280-304-23	Stainless Steel Wire Wheel (Fine)	4,000	4 (102)	23 (584)	Straight tip stainless-steel
PT280-304-11	Stainless Steel Wire Wheel (Fine)	4,000	4 (102)	.4 (10)	Straight, hardened stainless-steel tips
PT280-305-11	Stainless Steel Wire Wheel (Coarse)	4,000	4 (102)	.4 (10)	Bent, sharpened stainless-steel tips
PT280-305-23	Stainless Steel Wire Wheel (Coarse)	4,000	4 (102)	23 (584)	Bent, sharpened stainless-steel tips
PT280-306-11	Wire Wheel (Medium)	4,000	4 (102)	.4 (10)	Bent, sharpened spring steel tips
PT280-306-23	Wire Wheel (Medium)	4,000	4 (102)	23 (584)	Bent, sharpened spring steel tips

AIR/CORDLESS TOOL BOOTS



AT570B00T



YA972



MG725B00T



MG325B00T



YA975



AT370B00T



PH3050RB00T



FAR7000B00T



AT380B00T



CTB8172B00T



CT6850MRB00T

Protective Boots

Description	Size	Power Tool	Stock No.
Air Impact Wrench Boots	1/4" Sq. Drive	AT225B Series	YA975
		AT321	AT321-44
		AT360	AT360-25
	3/8" Sq. Drive	AT365	AT365B00T
		AT370	AT370B00T
		AT380 Series	AT380B00T
		CT30 Series	YA968
		MG31	MG31B00T
		MG325 Series	MG325B00T*
		AT355A	YA977
		IM31 Series	YA877A
		IM32 Series	YA1032
		1/2" Sq. Drive	AT123 Series
	IMC500		IMC500B00T
	AT560		AT560B00T
	AT570		AT570B00T
	AT600		AT600-23
	MG725 Series		MG725B00T*
	PT850		PT850B00T*
	AT500C, AT500D		YA972
	IM51 Series / IM510 Series		YA848
	IM5100 Series		YA978
	IM6100 Series/IM6500HP		YA980
	3/4" Sq. Drive	IM75	YA770
		AT670	AT670B00T
		AT760	AT760B00T
		MG1200, MG1250 Series	MG1200B00T
AT775, AT775L		YA979	
XT7100 Series		XT7100B00T	
Air Hammer Boots	—	AT2050	AT2050B00T
		PH3050, PH3050A, PH3050B	PH3050RB00T
		PH2045, PH2050	YA20500

*Colors Available

Description	Size	Power Tool.	Stock No.
Ratchet Boots	1/4" Sq. Drive, 3/8" Sq. Drive	AT200 Series, AT205 Series	AT200D22A,
		PTR200A, FAR2500, FAR2505, PTR205A, PTR215A, PTR225A and all 14.4 V ratchets, including CTR814, CTR817, CTR861, CTR867, CTR762 and CTR768	YA905
	1/2" Sq. Drive, 3/8" Sq. Drive	AT700 Series, AT702, AT705 Series	AT700E49A
	1/4" Sq. Drive	FAR25, FAR25A	YA888
	3/8" Sq. Drive	FAR7000	FAR7000B00T
		FAR7200, FAR72B, FAR72C, ETB14460A	YA889A
	Air Drill Boots	3/8" Capacity	AT3000
AT5000			AT5000B00T
PDR3A, PDR3000, PDR3001			YA883
PDR5A, PDR5000, PDR5001			YA885
Battery Boot			14.4 V
18 V	CTB8172 Series	CTB8172B00T*	
	CTB4185, CTB4187 Series	CTB4185B00T	
	CTB7185, CTB8185	CTB8185B00T	
Air Impact Wrench Boot (Blue-Point®)	3/8" Sq. Drive	CT3110, CT3110HP Series	YA969
	3/8" Sq. Drive, 1/2" Sq. Drive	CT310 Series, CT3450, CT3850 Series	YA982
Cordless Impact Wrench Boot	1/2" Sq. Drive	CT4850, CT6850, CT6855 Series	CT4850B00T
		CT4410A Series	CT4410AGB00T
		CT4410A Series	CT4410B00T
		CT6850 Series	CT6850MRB00T
		CT7850 Series	CT7850B00T
	1/2" and 3/8" Sq. Drive	CT8850, CT6818 Series	CT8850B00T*
		CT9050 Series	CT9050B00T
		CT9075, CT9080 Series	CT9075B00T
		CT8810, CT8815, CT4415, CT4818	CT8810B00T*
		CT761 Series	CT761B00T*
3/8" Sq. Drive	CT861 Series	CT861B00T	
	CT9010	CT9010B00T	

*Colors Available

Colors Available



* ADD SUFFIX TO STOCK NUMBER FOR SPECIAL COLORS.



- Use only accessories intended for each tool.
- Do not use accessories above their maximum recommended RPM.
- Do not use chipped or damaged accessories.
- Read Safety Precautions on pages W1-W4

DRILL ACCESSORIES



PTND4KA



PTNDM4KA



PTND5K

Magnetic Power Nut Drivers

- Magnets keep ferrous metal fasteners positioned in the driver
- High-grade alloy material for long-lasting durability
- Storage case keeps tools organized under the hood and on the bench

PTND4KA 4 pc SAE Magnetic Power Nut Setter Set

- Includes (4) magnetic power nut setters (1/4, 5/16, 3/8 and 1/2") in a storage case
- Magnets keep ferrous metal fasteners positioned in the driver
- High-grade alloy material for long-lasting durability

Stock No.	Description
PTND4KA516	5/16 SAE Magnetic Power Nut Setter
PTND4KA14	1/4" SAE Magnetic Power Nut Setter (Blue-Point®)
PTND4KA12	1/2" SAE Magnetic Power Nut Setter
PTND4KA38	3/8" SAE Magnetic Power Nut Setter (Blue-Point®)
PTNDM4KA8	8 mm Metric Magnetic Power Nut Setter (Blue-Point®)
PTNDM4KA10	10 mm Metric Magnetic Power Nut Setter (Blue-Point®)
PTNDM4KA12	12 mm Metric Magnetic Power Nut Setter
PTNDM4KA14	14 mm Metric Magnetic Power Nut Setter (Blue-Point®)
PTND5K716	7/16" SAE Magnetic Power Nut Setter (Blue-Point®)

PTNDM4KA 4 pc Metric Magnetic Power Nut Setter Set

- Includes (4) magnetic power nut setters (8, 10, 12 and 14 mm) in a storage case
- Magnets keep ferrous metal fasteners positioned in the driver
- High-grade alloy material for long-lasting durability

PTND5K 5 pc SAE Magnetic Nut Driver Set (Blue-Point®)

- Includes (5) magnetic power nut setters (1/4, 5/16, 3/8, 7/16 and 1/2") in a storage case
- All drivers 2-1/2" long
- Magnets keep ferrous metal fasteners positioned in the driver
- High-grade alloy material for long-lasting durability
- Storage case to keep the tools organized under the hood and on the bench



AT3000-26



DC15014



DC15038



DCBP500



PD30-3

Drill Accessories

AT3000-26 3/8" Keyless Chuck

- Use for AT3000 air drill

AT5000-6 Drill Chuck

- 1/2" keyed chuck fits AT5000
- Thread size 1/2"-20;
- Capacity 1/16" 1/2"
- Key not included

AT5000-6-1 Chuck Key

- 1/2" chuck key for AT5000

AT825-7 Chuck Key

- Chuck Key, 1/4"

DC150 8 pc Chuck Set (Blue-Point®)

- Includes 1/4" and 3/8" drill chucks, a chuck key and (5) stubby drill bits in 1/8, 3/16, 1/4, 5/16 and 3/8" sizes
- Includes a storage case

DC15014 1/4" Drill Chuck (Blue-Point®)

- Converts 1/4" drive impact wrenches to three-jaw, drill type chuck operation for impact drilling

DC15038 3/8" Drill Chuck (Blue-Point®)

- Converts 3/8" drive impact wrenches to three-jaw, drill type chuck operation for impact drilling

DC205989 S2A Chuck Key

- Use for DC208881 drill chuck

DC317255 3/8" Drill Chuck (For PDR3A)

- 3/8" chuck fits AT3000 drill
- Thread size 3/8"-24;
- Capacity 1/32" 3/8"
- Includes PD3A3 chuck key

DCBP500 1/2" Keyless Chuck

- Use on AT5000 air drill

DC64527 1/2" Drill Chuck

- 1/2" chuck fits AT3000 drill
- Thread size 3/8"-24;
- Capacity 1/16"-1/2"
- Includes PD30-3 chuck key

PD30-3 Chuck Key

- For PDR3A drill

PD3A3 Chuck Key

- 3/8" chuck key for PDR3A and AT800 drills

DRILL ACCESSORIES

Double Square Bit

BTSS620 Double Square Power Bit

- Provides extra clearance and minimizes tool contact with the work surface
- Minimizes potential damage to painted panels on RVs and trailers
- Ideal for use with all types of drills
- 6" long



BTSS620

Drill Accessories

DC150 8 pc Chuck Set (Blue-Point®)

- Includes 1/4" and 3/8" drill chucks, a chuck key and (5) stubby drill bits in 1/8, 3/16, 1/4, 5/16 and 3/8" sizes
- Includes a storage case



DC150

BIT SETS (Blue Point®)

Power Bit Sets

YA52PBSQC 52 pc Power Bit Set (Blue-Point®)

- For use with Snap-on® cordless screwdrivers and other power drivers
- Includes (7) six-lobe star (tamper-proof) insert bits, (3) square insert bits, (4) PHILLIPS® insert bits, (4) slotted insert bits, (7) hex insert bits, (2) clutch insert bits, (6) six-lobe star (tamper-proof) power bits, (3) square power bits, (3) PHILLIPS® power bits, (3) slotted power bits, (3) hex power bits, (3) socket adaptors, (1) quick-change chuck, (2) PHILLIPS® double end bits and (1) square bit holder in a storage case



YA52PBSQC

CTS561BITSET 23 pc 1/4" Drive Quick-Change Bit Set (Blue-Point®)

- For use with Snap-on® cordless screwdrivers and other power drivers
- Manufactured from industrial-grade tool steel
- Includes (22) bits (all 3" long), plus a 1/4" square drive (2" long)
- Includes PHILLIPS® bits #0, #1, #2; flat tip bits 5/32", 3/16", 7/16", 1/4", 9/32"; TORX® bits T10, T15, T20, T25, T27, T30, T40; hex bits 3/32", 7/64, 1/8", 5/32", 3/16", 7/32" and 1/4" in a storage case



CTS561BITSET

PTB32K 32 pc 1/4" Hex Shank Power Bit Set (Blue-Point®)

- For use with Snap-on® cordless screwdrivers and other power drivers
- Includes (2) adaptors, (5) flat tip bits 5/32–9/32", (7) hex bits 3/32–1/4", (4) PHILLIPS® bits 0, 1, 2 and 3, (4) Pozidriv® bits 0, 1, 2 and 3, (7) TORX® tamper-resistant bits T10–T40, (3) square bits 0, 1 and 2
- Storage case clearly indicates bit type and size



PTB32K

SPECIALIZED DRILL BITS

90° Angle Drill Set

YA 409 90° Angle Drill Kit (Blue-Point®)

- Allows drilling up to 1/4" holes in confined areas by positioning the bit at a 90° angle to the drill
- Threaded drill bits provide consistent concentricity and eliminate slippage
- Includes YA409 Drive unit; chucking spud; YA409-316M 3/16" bit (1-1/4" long); YA409-18L 1/8" bit (2-1/8" long); YA409-332L 3/32" bit (2-1/8" long); YA409-18M 1/8" bit (1-1/4" long); YA409-532M 5/32" bit (1-1/4" long); YA409-18S 1/8" bit (3/4" long); YA409-15 Storage Case



YA409



- Do not use bits with impact driver.
- Read Safety Precautions on pages W1–W4

DRILL BITS



DBTBC121

DBTBC129

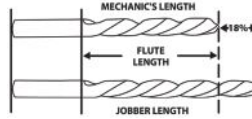

ThunderBit® Cobalt, 135° Split Point

- For drilling at higher speeds in tougher drilling conditions
- Feature 135° split points for easier drill starting without the need for center punching
- Heavy-duty web construction for higher strength and less breakage
- Improved chip ejection through a specially engineered flute design

Stock No.	Size, inches	Set Contains:	
DBTBC1/16 [‡]	1/16	•	•
DBTBC5/64 [‡]	5/64	•	•
DBTBC3/32 [‡]	3/32	•	•
DBTBC7/64 [‡]	7/64	•	•
DBTBC1/8 [‡]	1/8	•	•
DBTBC9/64 [‡]	9/64	•	•
DBTBC5/32 [‡]	5/32	•	•
DBTBC11/64 [‡]	11/64	•	•
DBTBC3/16 [‡]	3/16	•	•
DBTBC13/64 [‡]	13/64	•	•

Stock No.	Size, inches	Set Contains:	
DBTBC7/32 [‡]	7/32	•	•
DBTBC15/64 [‡]	15/64	•	•
DBTBC1/4 [‡]	1/4	•	•
DBTBC17/64 [‡]	17/64	•	•
DBTBC9/32 [‡]	9/32	•	•
DBTBC19/64 [‡]	19/64	•	•
DBTBC5/16 [‡]	5/16	•	•
DBTBC21/64 [‡]	21/64	•	•
DBTBC11/32 [‡]	11/32	•	•
DBTBC23/64 [‡]	23/64	•	•

Stock No.	Size, inches	Set Contains:	
DBTBC3/8 [‡]	—	•	•
DBTBC25/64 [‡]	25/64	•	•
DBTBC13/32 [‡]	13/32	•	•
DBTBC27/64 [‡]	27/64	•	•
DBTBC7/16 [‡]	7/16	•	•
DBTBC15/32 [‡]	15/32	•	•
DBTBC29/64 [‡]	29/64	•	•
DBTBC31/64 [‡]	31/64	•	•
DBTBC1/2 [‡]	1/2	•	•
B121B [‡]	Metal Index	•	•
B129B [‡]	Metal Index	•	•

DBTBC121[‡] 21 pc Cobalt ThunderBit® 135° Split Point Drill Bit Set (1/16–3/8")

- Includes DBTBC1/16–DBTBC3/8 in a metal drill index

DBTBC129[‡] 29 pc Cobalt ThunderBit® 135° Split Point Drill Bit Set (1/16–1/2")

- Includes DBTBC1/16–DBTBC1/2 in a metal drill index
- Bits drill at higher speeds in tougher drilling conditions
- 135° split points for easier drill starting without the need for center punching
- Heavy-duty web construction for higher strength and less breakage
- Improved chip ejection through a specially engineered flute design



DBTBM125K



ThunderBit® Metric High-Speed Steel, 135° Split Point

- 135° split points for easier drill starting without the need for center punching
- Semi-parabolic design provides improved chip and shaving ejection away from the hole to reduce heat on the bit
- Made with M2 premium high-speed steel
- Black and gold finish for multiple applications

Stock No.	Size, mm	Length, mm (inches)	Set Contains:
DBTBM1 [‡]	1	41 (1.61)	•
DBTBM1.5 [‡]	1.5	48 (1.89)	•
DBTBM2 [‡]	2	51 (2.01)	•
DBTBM2.5 [‡]	2.5	60 (2.36)	•
DBTBM3 [‡]	3	70 (2.76)	•
DBTBM3.5 [‡]	3.5	73 (2.87)	•
DBTBM4 [‡]	4	83 (3.27)	•
DBTBM4.5 [‡]	4.5	86 (3.39)	•
DBTBM5 [‡]	5	92 (3.62)	•

Stock No.	Size, mm	Length, mm (inches)	Set Contains:
DBTBM5.5 [‡]	5.5	95 (3.74)	•
DBTBM6 [‡]	6	102 (4.02)	•
DBTBM6.5 [‡]	6.5	105 (4.13)	•
DBTBM7 [‡]	7	105 (4.13)	•
DBTBM7.5 [‡]	7.5	111 (4.37)	•
DBTBM8 [‡]	8	114 (4.49)	•
DBTBM8.5 [‡]	8.5	121 (4.76)	•
DBTBM9 [‡]	9	124 (4.88)	•
DBTBM9.5 [‡]	9.5	127 (5)	•

Stock No.	Size, mm	Length, mm (inches)	Set Contains:
DBTBM10 [‡]	10	130 (5.12)	•
DBTBM10.5 [‡]	10.5	133 (5.24)	•
DBTBM11 [‡]	11	140 (5.51)	•
DBTBM12 [‡]	12	149 (5.87)	•
DBTBM12.5 [‡]	12.5	152 (5.98)	•
DBTBM13 [‡]	13	152 (5.98)	•

ThunderBit® High Speed Steel, 135° Split Point

- Industrial-grade steel with bronze-oxide surface treatment
- Bits will drill at higher speeds in tougher drilling conditions
- 135° split points for easier drill starting without the need for center punching
- Heavy-duty web construction for higher strength and less breakage
- Improved chip ejection through a specially engineered flute design



DBTB121



DBTB129

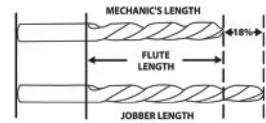

Stock No.	Size, inches	Set Contains:	
		DBTB121 [‡]	DBTB129 [‡]
DBTB1/16 [‡]	1/16	•	•
DBTB1/2 [‡]	1/2	•	•
DBTB1/4 [‡]	1/4	•	•
DBTB1/8 [‡]	1/8	•	•
DBTB11/32 [‡]	11/32	•	•
DBTB11/64 [‡]	11/64	•	•
DBTB13/32 [‡]	13/32	•	•
DBTB13/64 [‡]	13/64	•	•
DBTB15/32 [‡]	15/32	•	•
DBTB15/64 [‡]	15/64	•	•

Stock No.	Size, inches	Set Contains:	
		DBTB121 [‡]	DBTB129 [‡]
DBTB17/64 [‡]	17/64	•	•
DBTB19/64 [‡]	19/64	•	•
DBTB21/64 [‡]	21/64	•	•
DBTB23/64 [‡]	23/64	•	•
DBTB25/64 [‡]	25/64	•	•
DBTB27/64 [‡]	27/64	•	•
DBTB29/64 [‡]	29/64	•	•
DBTB3/16 [‡]	3/16	•	•
DBTB3/32 [‡]	3/32	•	•
DBTB3/8 [‡]	3/8	•	•

Stock No.	Size, inches	Set Contains:	
		DBTB121 [‡]	DBTB129 [‡]
DBTB31/64 [‡]	31/64	•	•
DBTB5/16 [‡]	5/16	•	•
DBTB5/32 [‡]	5/32	•	•
DBTB5/64 [‡]	5/64	•	•
DBTB7/16 [‡]	7/16	•	•
DBTB7/32 [‡]	7/32	•	•
DBTB7/64 [‡]	7/64	•	•
DBTB9/32 [‡]	9/32	•	•
DBTB9/64 [‡]	9/64	•	•
B121B [‡]	Metal Index	•	•
B129F [‡]	Metal Index	•	•

DBTB121[‡] 21 pc Jobber Length ThunderBit® High-Speed 135° Split Point Drill Bit Set (1/16–3/8")

- Includes DBTB1/16–DBTB3/8 (21 bits) in a metal drill index

DBTB129[‡] 29 pc Jobber Length ThunderBit® High-Speed 135° Split Point Drill Bit Set (1/16–1/2")

- Includes 1/16–1/2" in a metal drill index

Mechanic's Length, 135° Point with Three-Flat Shank

Stock No.	Size, inches	Set Contains:	
		DBTR11 [‡]	DBTR129 [‡]
DBTR1/16 [‡]	1/16	•	•
DBTR5/64 [‡]	5/64	•	•
DBTR3/32 [‡]	3/32	•	•
DBTR7/64 [‡]	7/64	•	•
DBTR1/8 [‡]	1/8	•	•
DBTR9/64 [‡]	9/64	•	•
DBTR5/32 [‡]	5/32	•	•
DBTR11/64 [‡]	11/64	•	•
DBTR3/16 [‡]	3/16	•	•
DBTR13/64 [‡]	13/64	•	•
DBTR7/32 [‡]	7/32	•	•
DBTR15/64 [‡]	15/64	•	•
DBTR1/4 [‡]	1/4	•	•
DBTR17/64 [‡]	17/64	•	•
DBTR9/32 [‡]	9/32	•	•

Stock No.	Size, inches	Set Contains:	
		DBTR11 [‡]	DBTR129 [‡]
DBTR19/64 [‡]	19/64	•	•
DBTR5/16 [‡]	5/16	•	•
DBTR21/64 [‡]	21/64	•	•
DBTR11/32 [‡]	11/32	•	•
DBTR23/64 [‡]	23/64	•	•
DBTR3/8 [‡]	3/8	•	•
DBTR25/64 [‡]	25/64	•	•
DBTR13/32 [‡]	13/32	•	•
DBTR27/64 [‡]	27/64	•	•
DBTR7/16 [‡]	7/16	•	•
DBTR29/64 [‡]	29/64	•	•
DBTR15/32 [‡]	15/32	•	•
DBTR31/64 [‡]	31/64	•	•
DBTR1/2 [‡]	1/2	•	•
B128M	Metal Index	•	•
DBTR11-1 [‡]	Kit Bag	•	•



DBTR11



DBTR129

DBTR11[‡] 11 pc High-Speed Mechanic's Length 135° Point with Three-Flat Shank Drill Bit Set

- Includes (11) high-speed mechanic's length 135° point with three flat shank drill bits (1/16, 3/32, 1/8, 5/32, 3/16, 7/32, 1/4, 9/32, 5/16, 11/32 and 3/8") in a kit bag

DBTR129[‡] 29 pc High-Speed Mechanic's Length 135° Point with Three-Flat Shank Drill Bit Set

- Includes (29) drill bits (1/16–1/2") in a metal drill index



‡These products can expose you to chemicals which are known to the state of California to cause cancer and reproductive harm. See pages P1–P2 for details.
• Read Safety Precautions on pages W1–W4

DRILL BITS



GA219B

Hole Cutters

GA219B Hole Cutter Kit (Blue-Point®)

- Cuts holes in sheet metal, pipe, plastic and wood up to 1/4" thick
- Special design helps to prevent clogging; cutting doesn't need to be interrupted to clear chips
- Includes (7) high-speed steel cutters (5/16, 3/8, 7/16, 1/2, 9/16, 5/8 and 3/4"), an arbor with a spring-loaded pilot guide, a hex wrench, an extra pilot, stop and spacer washers in a storage case

- GA219A1MP3 5/16" Cutter
- GA219A2MP3 3/8" Cutter
- GA219A3MP3 7/16" Cutter
- GA219A4MP3 1/2" Cutter
- GA219A5MP3 9/16" Cutter
- GA219A7MP3 5/8" Cutter
- GA219A10MP3 3/4" Cutter
- GA219-9A Arbor

- GA219A9A 3/8"-24 Arbor Assembly with Pilot
- GA219B1 Center Punch
- GA219A9-2A Ejector Spring
- GA219A8 Pilot
- GA219A12 3/8 x 7/8" Stop Washer with Flats
- GA219A13 Washer 3/8 x 9/16



DBTRCS11

Cobalt Short Length Drill Bits

Set Contains:

DBTRCS11[†]

Stock No.	Length, inches	
DBTRCS1/16 [†]	1.65	•
DBTRCS3/32 [†]	1.79	•
DBTRCS1/8 [†]	1.94	•
DBTRCS5/32 [†]	2.13	•
DBTRCS3/16 [†]	2.25	•
DBTRCS7/32 [†]	2.44	•
DBTRCS1/4 [†]	2.58	•
DBTRCS9/32 [†]	2.77	•
DBTRCS5/16 [†]	2.90	•
DBTRCS11/32 [†]	3.10	•
DBTRCS3/8 [†]	3.24	•

DBTRCS11[†] 11 pc Cobalt Short Length Drill Bit Set

- Shorter length bits access tight spaces
- Flats on larger-sized drill bits provide a better grip on the tool in the chuck (3/16–3/8")
- Comes with custom kit bag

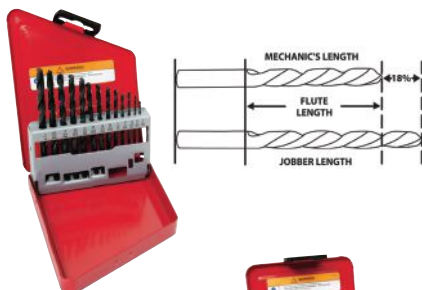

DB113C

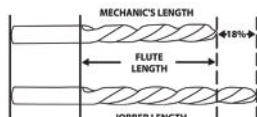

Jobber Length, 118° Point

Set Contains:

DB113C[†] DB121C[†] DB129C[†]

Stock No.	Size, inches	DB113C [†]	DB121C [†]	DB129C [†]
DBF1/16C [†]	1/16	•	•	•
DBF5/64C [†]	5/64	•	•	•
DBF3/32C [†]	3/32	•	•	•
DBF7/64C [†]	7/64	•	•	•
DBF1/8C [†]	1/8	•	•	•
DBF9/64C [†]	9/64	•	•	•
DBF5/32C [†]	5/32	•	•	•
DBF11/64C [†]	11/64	•	•	•
DBF3/16C [†]	3/16	•	•	•
DBF13/64C [†]	13/64	•	•	•
DBF7/32C [†]	7/32	•	•	•
DBF15/64C [†]	15/64	•	•	•
DBF1/4C [†]	1/4	•	•	•
DBF17/64C [†]	17/64	•	•	•
DBF9/32C [†]	9/32	•	•	•
DBF19/64C [†]	19/64	•	•	•



DB121C

DB129C

DB113C[†] 13 pc High-Speed Jobber Length 118° Point Drill Bit Set

- Includes (13 pc) (1/16–1/4")
- Includes metal drill index

DB121C[†] 21 pc High-Speed Jobber Length 118° Point Drill Bit Set

- Includes (21 pc) (1/16–3/8")
- Includes metal drill index

DB129C[†] 29 pc High-Speed Jobber Length 118° Point Drill Bit Set

- Includes (29 pc) (1/16–1/2")
- Includes metal drill index

Stock No.	Size, inches	DB113C [†]	DB121C [†]	DB129C [†]
DBF5/16C [†]	5/16		•	•
DBF21/64C [†]	21/64		•	•
DBF11/32C [†]	11/32		•	•
DBF23/64C [†]	23/64		•	•
DBF3/8C [†]	3/8		•	•
DBF25/64C [†]	25/64			•
DBF13/32C [†]	13/32			•
DBF27/64C [†]	27/64			•
DBF7/16C [†]	7/16			•
DBF29/64C [†]	29/64			•
DBF15/32C [†]	15/32			•
DBF31/64C [†]	31/64			•
DBF1/2C [†]	1/2			•
B113B [†]			•	
B121C [†]	Metal Drill Index		•	
B129C [†]				•

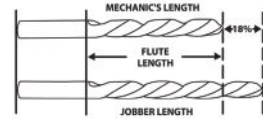

Jobber Length, Letter Size, 118° Point

DBA126B [‡] Set Contains:		
Stock No.	Decimal Equivalent, inches	
DBAA1A [‡]	.234 (A)	•
DBAA1B [‡]	.238 (B)	•
DBAA1C [‡]	.242 (C)	•
DBAA1D [‡]	.246 (D)	•
DBAA1E [‡]	.250 (E)	•
DBAA1F [‡]	.257 (F)	•
DBAA1G [‡]	.261 (G)	•
DBAA1H [‡]	.266 (H)	•
DBAA1I [‡]	.272 (I)	•
DBAA1J [‡]	.277 (J)	•
DBAA1K [‡]	.281 (K)	•
DBAA1L [‡]	.290 (L)	•
DBAA1M [‡]	.295 (M)	•

DBA126B [‡] Set Contains:		
Stock No.	Decimal Equivalent, inches	
DBAA1N [‡]	.302 (N)	•
DBAA1O [‡]	.316 (O)	•
DBAA1P [‡]	.323 (P)	•
DBAA1Q [‡]	.332 (Q)	•
DBAA1R [‡]	.339 (R)	•
DBAA1S [‡]	.348 (S)	•
DBAA1T [‡]	.358 (T)	•
DBAA1U [‡]	.368 (U)	•
DBAA1V [‡]	.377 (V)	•
DBAA1W [‡]	.386 (W)	•
DBAA1X [‡]	.397 (X)	•
DBAA1Y [‡]	.404 (Y)	•
DBAA1Z [‡]	.413 (Z)	•
B126C [‡]	Metal Index	•



DBA126B

DBA126B[‡] 26 pc High-Speed Jobber Length Letter Size 118° Point Drill Bit Set

- Includes (26 pc) (.234–.413") (A–Z) in a metal index (B126C)

Jobber Length, Metric, 118° Point

DBM125C [‡] Set Contains:		
Stock No.	Size, mm	
DBM1A [‡]	1	•
DBM1.5A [‡]	1.5	•
DBM2.5A [‡]	2.5	•
DBM2A [‡]	2	•
DBM3A [‡]	3	•
DBM3.5A [‡]	3.5	•
DBM4A [‡]	4	•
DBM4.5A [‡]	4.5	•
DBM5A [‡]	5	•
DBM5.5A [‡]	5.5	•
DBM6A [‡]	6	•
DBM6.5A [‡]	6.5	•
DBM7A [‡]	7	•

DBM125C [‡] Set Contains:		
Stock No.	Size, mm	
DBM7.5A [‡]	7.5	•
DBM8A [‡]	8	•
DBM8.5A [‡]	8.5	•
DBM9A [‡]	9	•
DBM9.5A [‡]	9.5	•
DBM10A [‡]	10	•
DBM10.5A [‡]	10.5	•
DBM11A [‡]	11	•
DBM11.5A [‡]	11.5	•
DBM12A [‡]	12	•
DBM12.5A [‡]	12.5	•
DBM13A [‡]	13	•
B125C [‡]	Metal Index	•



DBM125C

DBM125C[‡] 25 pc Jobber Length Metric Size 118° Point Drill Bit Set

- Includes (25 pc) (1–13 mm) in a metal index (B125C)



- Do not use bits with impact drivers.
- ‡These products can expose you to chemicals which are known to the state of California to cause cancer and reproductive harm. See pages P1–P2 for details.
- Read Safety Precautions on pages W1–W4

WIRE GAUGE DRILL BITS



DB160C



DB120C



B160C

Wire Gauge,
118° Point (Cobalt and
High Speed Steel)

Cobalt	High-Speed Steel	Decimal Equivalent, inches	Length, inches	Set Contains:		
				DBC260A [‡]	DB160C [‡]	DB120C [‡]
Cobalt	High-Speed Steel	Decimal Equivalent, inches	Length, inches	Cobalt	High-Speed	High-Speed
DBCE1A [‡]	DBE1B [‡]	.2280	3-7/8	•	•	
DBCE2A [‡]	DBE2B [‡]	.2210	3-7/8	•	•	
DBCE3A [‡]	DBE3B [‡]	.2130	3-3/4	•	•	
DBCE4A [‡]	DBE4B [‡]	.2090	3-3/4	•	•	
DBCE5A [‡]	DBE5B [‡]	.2055	3-3/4	•	•	
DBCE6A [‡]	DBE6B [‡]	.2040	3-3/4	•	•	
DBCE7A [‡]	DBE7B [‡]	.2010	3-5/8	•	•	
DBCE8A [‡]	DBE8B [‡]	.1990	3-5/8	•	•	
DBCE9A [‡]	DBE9B [‡]	.1960	3-5/8	•	•	
DBCE10A [‡]	DBE10B [‡]	.1935	3-5/8	•	•	
DBCE11A [‡]	DBE11B [‡]	.1910	3-1/2	•	•	
DBCE12A [‡]	DBE12B [‡]	.1890	3-1/2	•	•	
DBCE13A [‡]	DBE13B [‡]	.1850	3-1/2	•	•	
DBCE14A [‡]	DBE14B [‡]	.1820	3-3/8	•	•	
DBCE15A [‡]	DBE15B [‡]	.1800	3-3/8	•	•	
DBCE16A [‡]	DBE16B [‡]	.1770	3-3/8	•	•	
DBCE17A [‡]	DBE17B [‡]	.1730	3-3/8	•	•	
DBCE18A [‡]	DBE18B [‡]	.1695	3-1/4	•	•	
DBCE19A [‡]	DBE19B [‡]	.1660	3-1/4	•	•	
DBCE20A [‡]	DBE20B [‡]	.1610	3-1/4	•	•	
DBCE21A [‡]	DBE21B [‡]	.1590	3-1/4	•	•	
DBCE22A [‡]	DBE22B [‡]	.1570	3-1/8	•	•	
DBCE23A [‡]	DBE23B [‡]	.1540	3-1/8	•	•	
DBCE24A [‡]	DBE24B [‡]	.1520	3-1/8	•	•	
DBCE25A [‡]	DBE25B [‡]	.1495	3	•	•	
DBCE26A [‡]	DBE26B [‡]	.1470	3	•	•	
DBCE27A [‡]	DBE27B [‡]	.1440	3	•	•	
DBCE28A [‡]	DBE28B [‡]	.1405	2-7/8	•	•	
DBCE29A [‡]	DBE29B [‡]	.1360	2-7/8	•	•	
DBCE30A [‡]	DBE30B [‡]	.1285	2-3/4	•	•	
DBCE31A [‡]	DBE31B [‡]	.1200	2-3/4	•	•	
DBCE32A [‡]	DBE32B [‡]	.1160	2-3/4	•	•	
DBCE33A [‡]	DBE33B [‡]	.1130	2-5/8	•	•	
DBCE34A [‡]	DBE34B [‡]	.1110	2-5/8	•	•	
DBCE35A [‡]	DBE35B [‡]	.1100	2-5/8	•	•	
DBCE36A [‡]	DBE36B [‡]	.1065	2-1/2	•	•	
DBCE37A [‡]	DBE37B [‡]	.1040	2-1/2	•	•	
DBCE38A [‡]	DBE38B [‡]	.1015	2-1/2	•	•	
DBCE39A [‡]	DBE39B [‡]	.0995	2-3/8	•	•	
DBCE40A [‡]	DBE40B [‡]	.0980	2-3/8	•	•	

Cobalt	High-Speed Steel	Decimal Equivalent, inches	Length, inches	Set Contains:		
				DBC260A [‡]	DB160C [‡]	DB120C [‡]
Cobalt	High-Speed Steel	Decimal Equivalent, inches	Length, inches	Cobalt	High-Speed	High-Speed
DBCE41A [‡]	DBE41B [‡]	.0960	2-3/8	•	•	
DBCE42A [‡]	DBE42B [‡]	.0935	2-1/4	•	•	
DBCE43A [‡]	DBE43B [‡]	.0890	2-1/4	•	•	
DBCE44A [‡]	DBE44B [‡]	.0860	2-1/8	•	•	
DBCE45A [‡]	DBE45B [‡]	.0820	2-1/8	•	•	
DBCE46A [‡]	DBE46B [‡]	.0810	2-1/8	•	•	
DBCE47A [‡]	DBE47B [‡]	.0785	2	•	•	
DBCE48A [‡]	DBE48B [‡]	.0760	2	•	•	
DBCE49A [‡]	DBE49B [‡]	.0730	2	•	•	
DBCE50A [‡]	DBE50B [‡]	.0700	2	•	•	
DBCE51A [‡]	DBE51B [‡]	.0670	2	•	•	
DBCE52A [‡]	DBE52B [‡]	.0635	1-7/8	•	•	
DBCE53A [‡]	DBE53B [‡]	.0595	1-7/8	•	•	
DBCE54A [‡]	DBE54B [‡]	.0550	1-7/8	•	•	
DBCE55A [‡]	DBE55B [‡]	.0520	1-7/8	•	•	
DBCE56A [‡]	DBE56B [‡]	.0465	1-3/4	•	•	
DBCE57A [‡]	DBE57B [‡]	.0430	1-3/4	•	•	
DBCE58A [‡]	DBE58B [‡]	.0420	1-5/8	•	•	
DBCE59A [‡]	DBE59B [‡]	.0410	1-5/8	•	•	
DBCE60A [‡]	DBE60B [‡]	.0400	1-5/8	•	•	
	DBE61B [‡]	.0390	1-5/8			•
	DBE62B [‡]	.0380	1-1/2			•
	DBE63B [‡]	.0370	1-1/2			•
	DBE64B [‡]	.0360	1-1/2			•
	DBE65B [‡]	.0350	1-1/2			•
	DBE66B [‡]	.0330	1-3/8			•
	DBE67B [‡]	.0320	1-3/8			•
	DBE68B [‡]	.0310	1-3/8			•
	DBE69B [‡]	.0292	1-3/8			•
	DBE70B [‡]	.0280	1-1/4			•
	DBE71B [‡]	.0260	1-1/4			•
	DBE72B [‡]	.0250	1-1/8			•
	DBE73B [‡]	.0240	1-1/8			•
	DBE74B [‡]	.0225	1 (25.4)			•
	DBE75B [‡]	.0210	1 (25.4)			•
	DBE76B [‡]	.0200	7/8			•
	DBE77B [‡]	.0180	7/8			•
	DBE78B [‡]	.0160	7/8			•
	DBE79B [‡]	.0145	—			•
	DBE80B [‡]	.0135	—			•
B160C [‡]	Metal Drill Bit Index			•	•	

DBC260A[‡] 60 pc Cobalt Wire Gauge 118° Point Drill Bit Set

- Includes (60 pc) (.2280–.0400")
- Includes metal drill index

DB160C[‡] 60 pc High-Speed Steel Wire Gauge 118° Point Drill Bit Set

- Includes (60 pc) (.2280–.0400")
- Includes metal drill index

DB120C[‡] 20 pc High-Speed Wire Gauge 118° Point Drill Bit Set

- Includes (20 pc) (.0390–.0135")
- Includes metal drill index

Jobber Length, Cobalt, 135° Point (Blue-Point®)

Stock No.	Size, inches	Stock No.	Size, inches
DBBPC1/16	1/16	DBBPC15/64	15/64
DBBPC5/64	5/64	DBBPC1/4	1/4
DBBPC3/32	3/32	DBBPC17/64	17/64
DBBPC7/64	7/64	DBBPC9/32	9/32
DBBPC1/8	1/8	DBBPC19/64	19/64
DBBPC9/64	9/64	DBBPC5/16	5/16
DBBPC5/32	5/32	DBBPC21/64	21/64
DBBPC11/64	11/64	DBBPC11/32	11/32
DBBPC3/16	3/16	DBBPC23/64	23/64
DBBPC13/64	13/64	DBBPC3/8	3/8
DBBPC7/32	7/32		



DBBPC21

DBBPC21 21 pc Cobalt Drill Bit Set (Blue-Point®)

- Ideal for drilling low- and medium-carbon steel, plus steel alloy
- 135° split point penetrates on contact and prevents walking of the bit
- Jobber length for access in tight locations
- Cobalt construction for higher temperature applications
- Use CL6 Cutting Oil to maximize drill bit life
- Includes DBBPC1/16–DBBPC3/8 (1/16–3/8") in metal drill bit index

Jobber Length, High-Speed Steel, 135° Point (Blue-Point®)

Stock No.	Size, inches	Stock No.	Size, inches
DBBP1/16	1/16	DBBP15/64	15/64
DBBP5/64	5/64	DBBP1/4	1/4
DBBP3/32	3/32	DBBP17/64	17/64
DBBP7/64	7/64	DBBP9/32	9/32
DBBP1/8	1/8	DBBP19/64	19/64
DBBP9/64	9/64	DBBP5/16	5/16
DBBP5/32	5/32	DBBP21/64	21/64
DBBP11/64	11/64	DBBP11/32	11/32
DBBP3/16	3/16	DBBP23/64	23/64
DBBP13/64	13/64	DBBP3/8	3/8
DBBP7/32	7/32		



DBBP21

DBBP21 21 pc HSS Drill Bit Set (Blue-Point®)

- Includes (21) drill bits (1/16–3/8")
- Includes metal drill index

Jobber Length, HSS Titanium Coated, 135° Point (Blue-Point®)

Stock No.	Size, inches	Stock No.	Size, inches
DBBPT1/16	1/16	DBBPT11/64	11/64
DBBPT5/64	5/64	DBBPT3/16	3/16
DBBPT3/32	3/32	DBBPT13/64	13/64
DBBPT7/64	7/64	DBBPT7/32	7/32
DBBPT1/8	1/8	DBBPT15/64	15/64
DBBPT9/64	9/64	DBBPT1/4	1/4
DBBPT5/32	5/32		



DBBPT13

DBBPT13 13 pc HSS Titanium-Coated Drill Bit Set (Blue-Point®)

- Ideal for drilling aluminum, copper, plastic and cast iron
- Titanium-coated high-speed steel for heavy-duty applications
- Designed for increased speed and feed rates
- 135° point
- Titanium coating resists rust
- Use CL6 Cutting Oil to maximize drill bit life
- Includes DBBPT1/16–DBBPT1/4 (1/16–1/4") in metal drill bit index



‡These products can expose you to chemicals which are known to the state of California to cause cancer and reproductive harm. See pages P1–P2 for details.
• Read Safety Precautions on pages W1–W4

SPECIALIZED DRILL BITS

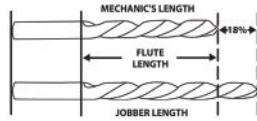

DBD110A



DBD1/8AMP10

Double-Ended, 135° Split Point

Set Contains: **DBD110A[‡]**

Stock No.	Description	Size	
DBD7/64A[‡]	7/64" Double Ended Drill Bit	7/64"	•
DBD1/8A[‡]	1/8" Double Ended 135° Split Point Drill Bit	1/8"	•
DBD9/64A[‡]	9/64" Double Ended Drill Bit	9/64"	•
DBD5/32A[‡]	5/32" Double Ended Drill Bit	5/32"	•
DBD3/16A[‡]	3/16" Double Ended 135° Split Point Drill Bit	3/16"	•
DBD7/32A[‡]	7/32" Double Ended Drill Bit	7/32"	•
DBD1/4A[‡]	1/4" Double Ended 135° Split Point Drill Bit	1/4"	•
DBD11A[‡]	#11 Double Ended Drill Bit	#11	•
DBD20A[‡]	#20 Double Ended Drill Bit	#20	•
DBD30A[‡]	#30 Double Ended Drill Bit	#30	•

DBD110A[‡] 10 pc Double-Ended 135° Split Point Drill Bit Set

- Includes (10 pc) (7/64–1/4", #11, #20 and #30)
- Includes a plastic pouch

DBD1/8AMP10[‡] 1/8" Double-Ended 135° Split Point Drill Bit

- Used for pop rivet applications and drilling thin sheet metal
- 135° split point for fast penetration
- Made from long-lasting high-speed steel
- (10 pc) of DBD1/8A drill bits

Left-Hand Fractional Drill Bits, High Speed Steel



DBLS105B

Stock No.	Size, inches
DBLS1/8B[‡]	1/8
DBLS3/16B[‡]	3/16
DBLS1/4B[‡]	1/4

Stock No.	Size, inches
DBLS5/16B[‡]	5/16
DBLS11/32B[‡]	11/32

DBLS105B[‡] 5 pc Left-Hand High-Speed Drill Bit Set

- Use left-hand drill bits to make a hole in the broken screw before the extractor is inserted
- Left-hand drill bits tend to loosen screws for easier removal
- Set includes (5) drill bits (1/8–11/32) in a plastic pouch

Left-Hand Fractional Drill Bits, Cobalt



DBCL105B

Set Contains: **DBCL105B[‡]**

Stock No.	Size, inches	
DBCL5/64B[‡]	5/64	•
DBCL7/64B[‡]	7/64	•
DBCL5/32B[‡]	5/32	•
DBCL3/16A[‡]	3/16	
DBCL1/4B[‡]	1/4	•
DBCL9/32A[‡]	9/32	
DBCL1/2A[‡]	1/2	
DBCL19/64B[‡]	19/64	•

Set Contains: **DBCL105B[‡]**

Stock No.	Size, inches	
DBCL5/16A[‡]	5/16	
DBCL11/32A[‡]	11/32	
DBCL3/8A[‡]	3/8	
DBCL13/32A[‡]	13/32	
DBCL7/16A[‡]	7/16	
DBCL15/32A[‡]	15/32	
DBCL1/2A[‡]	1/2	

DBCL105B[‡] 5 pc Left-Hand Cobalt Drill Bit Set

- Use left-hand drill bits to make a hole in the broken screw before the extractor is inserted
- Left-hand drill bits tend to loosen screws for easier removal
- Set includes DBCL5/64B, DBCL7/64B, DBCL5/32B, DBCL1/4B and DBCL19/64B drill bits in a plastic pouch

Stock No.	Size, inches	Set Contains:	
		DBH1B	DBH7B
DBH1/16B	1/16	•	•
DBH3/32B	3/32	•	•
DBH1/8B	1/8	•	•
DBH5/32B	5/32	•	•
DBH3/16B	3/16	•	•
DBH7/32B	7/32	•	•
DBH1/4BB	1/4	•	•
DBH9/32B	9/32	•	
DBH5/16B	5/16	•	
DBH11/32B	11/32	•	
DBH3/8B	3/8	•	

DBH7B 7 pc Hex Shank Drill Bit Set

- Includes (7 pc) DBH1/16B–DBH1/4BB (1/16–1/4") in DBH7B-1 kit bag

DBH11B 11 pc Hex Shank Drill Bit Set

- Includes DBH1/16B–DBH3/8B (1/16–3/8") in DBH11B-1 kit bag



DBH7B



DBH11B

Hex Shank Drill Bits

- Black-oxide finish prevents rust and reduces operating temperature
- 118° point provides fast starts and optimal performance in thin-gauge material
- Hex drive design provides the ability to quickly adapt to all hex drive chucks
- Tapered fit of drill to hex drive shank eliminates bit wobble or runout to provide easier starting and a more precise hole
- Screw machine length allows the bits to be used in tight spaces
- Made in the US

Left-Hand Short Fractional Drill Bits, Cobalt

Stock No.	Size, inches	Set Contains:	
		DBTRCSL1†	
DBTRCSL1/16†	1/16	•	
DBTRCSL3/32†	3/32	•	
DBTRCSL1/8†	1/8	•	
DBTRCSL5/32†	5/32	•	
DBTRCSL3/16†	3/16	•	
DBTRCSL7/32†	7/32	•	
DBTRCSL1/4†	1/4	•	
DBTRCSL9/32†	9/32	•	
DBTRCSL5/16†	5/16	•	
DBTRCSL11/32†	11/32	•	
DBTRCSL3/8†	3/8	•	

DBTRCSL11† 11 pc Left-Hand Cobalt Short Drill Bit Set with Flats

- Screw machine length for getting into smaller areas
- Flats on larger sized drill bits provide a better grip when used with keyless chucks (3/16–3/8")
- Left-hand flute for removing broken bolts
- Cobalt steel for drilling harder materials
- Bit lengths from 1.7–3.1"
- 11 most popular drill sizes in one set
- Includes (11) bits and a kit bag



DBTRCSL11

90° Angle Drill Set

Size	Set Contains:		
	2-1/8" Long Bit Stock No.	1-1/4" Medium Bit Stock No.	3/4" Short Bit Stock No.
#10	YA409-10L	YA409-10M	YA409-10S
#11	—	—	YA409-11S
#13	—	—	YA409-13S
#20	—	—	YA409-20S
#21	—	—	YA409-21S
#30	YA409-30L	YA409-30M	YA409-30S
1/8"	YA409-18L	YA409-18M	YA409-18S
3/16"	YA409-316L	YA409-316M	YA409-316S
3/32"	YA409-332L	YA409-332M	YA409-332S
#40	YA409-40L	YA409-40M	YA409-40S
5/32"	YA409-532L	YA409-532M	YA409-532S
1/4"	YA409-14L	YA409-14M	YA409-14S

YA409 90° Angle Drill Kit (Blue-Point®)

- Allows drilling up to 1/4" holes in confined areas by positioning the bit at a 90° angle to the drill
- Threaded drill bits provide consistent concentricity and eliminate slippage
- Includes
 - YA409 Drive unit; chucking spud
 - YA409-316M 3/16" bit (1-1/4" long)
 - YA409-18L 1/8" bit (2-1/8" long)
 - YA409-332L 3/32" bit (2-1/8" long)
 - YA409-18M 1/8" bit (1-1/4" long)
 - YA409-532M 5/32" bit (1-1/4" long)
 - YA409-18S 1/8" bit (3/4" long)
 - YA409-15 Storage Case



YA409

YA409-6 Threaded Collet (Blue-Point®)

- Allows the use of 1/4" dia. shank grinding burrs and abrasive wheels



†These products can expose you to chemicals which are known to the state of California to cause cancer and reproductive harm. See pages P1–P2 for details.
• Read Safety Precautions on pages W1–W4

SPECIALIZED DRILL BITS

1/2" Reduced-Shank Drill Bit, 118° Point

- Ideal for cutting in low- and medium-tensile strength materials
- Flatted shank provides a more secure grip for the drill chuck



CSE485B

Stock No.	Size, inches	Stock No.	Size, inches
CSE345B [‡]	17/32	CSE475 [‡]	45/64
CSE365B [‡]	9/16	CSE485B [‡]	3/4
CSE375 [‡]	37/64	CSE505B [‡]	25/32
CSE385B [‡]	19/32	CSE525B [‡]	13/16
CSE405B [‡]	5/8	CSE565B [‡]	7/8
CSE425B [‡]	21/32	CSE575 [‡]	59/64
CSE445B [‡]	11/16	CSE605B [‡]	15/16
CSE465B [‡]	23/32	CSE645B [‡]	1

[‡]Use with TDP6 Pipe Tap Set.

Aircraft Length, 135° Split Point

- Extra-long bits for drilling thick materials



DBK7A

Set Contains:

DBK7A[‡]

Stock No.	Size, inches	Flute Length, inches	Length, inches	
DBT1/8A [‡]	1/8	1-5/8	12	•
DBT3/16A [‡]	3/16	2-1/4	12	•
DBT1/4A [‡]	1/4	2-3/4	12	•
DBT5/16A [‡]	5/16	3-1/4	12	•
DBT3/8A [‡]	3/8	3-3/4	12	•
DBT7/16A [‡]	7/16	4	12	•
DBT1/2A [‡]	1/2	4-1/2	12	•

Titanium-Nitride Step Drills

- Titanium-nitride coating creates a surface hardness that makes these tools last 4 to 5 times longer than ordinary drill bits
- Surface coating also reduces friction, resulting in a tool that runs cooler while running dry



YA1TA



YA263A

Step Drills

Set Contains:

YA203A

Stock No.	Size Range	Increments	Shank Size, inches (mm)	Hole Sizes Per Bit	Length, inches
YA1TA	1/8-1/2"	1/32"	1/4 (6.5)	13	3-1/4
YA2TA	3/16-1/2"	1/16"	1/4 (6.5)	6	3-1/4
YA4TA	3/16-7/8"	1/16"	3/8 (10)	12	3
YA1MTA	4-12 mm	1 mm	1/4 (6.5)	9	3-1/4
YA3MTA	6-18 mm	2 mm	3/8 (10)	7	2-5/8
YA4MTA	4-22 mm	2 mm	3/8 (10)	10	3
YA5MTA	5-35 mm	2-3 mm	1/2 (13)	13	3-3/32

Stock No.	Size Range, inches	Increments, inches	Shank Size, inches	Hole Sizes Per Bit	Length, inches
YA261A	1/8-1/2	1/32	1/4	13	3-1/4
YA262A	3/16-1/2	1/16	1/4	6	3-3/8
YA263A	1/4-3/4	1/16	3/8	9	2-5/8
YA265A	3/16-3/8	1/16	1/4	5	1-5/8
YA267A	3/16-7/8	1/16	3/8	12	3
YA266A	9/16-1	1/16	1/2	8	2-1/2

HOLE SAWS



LHS18D



LHS48D



LHS64D



LHS608B



LHS606D

Hole Saws

- High-speed cutting edge is welded to an alloy steel back to absorb shocks
- Cut clean, accurate holes in steel and cast iron pipe, steel plates, aluminum, copper, brass, stainless steel, wood or plastic
- Side slits make it easy to knock out the spent disks

Stock No.	Diameter, inches	Recommended Arbors
LHS18D	9/16	LHS1C, LHS6C
LHS20D	5/8	LHS1C, LHS6C
LHS22D	11/16	LHS1C, LHS6C
LHS24D	3/4	LHS1C, LHS6C
LHS26D	13/16	LHS1C, LHS6C
LHS28D	7/8	LHS1C, LHS6C
LHS30D	15/16	LHS1C, LHS6C
LHS32D	1	LHS1C, LHS6C
LHS34D	1-1/16	LHS1C, LHS6C
LHS36D	1-1/8	LHS1C, LHS6C
LHS38D	1-3/16	LHS1C, LHS6C
LHS40D	1-1/4	LHS3D
LHS42D	1-5/16	LHS3D
LHS44D	1-3/8	LHS3D
LHS46D	1-7/16	LHS3D
LHS48D	1-1/2	LHS3D

Stock No.	Diameter, inches	Recommended Arbors
LHS50D	1-9/16	LHS3D
LHS52D	1-5/8	LHS3D
LHS54D	1-11/16	LHS3D
LHS56D	1-3/4	LHS3D
LHS58D	1-13/16	LHS3D
LHS60D	1-7/8	LHS3D
LHS64D	2	LHS3D
LHS66D	2-1/16	LHS3D
LHS68D	2-1/8	LHS3D
LHS72D	2-1/4	LHS3D
LHS76D	2-3/8	LHS3D
LHS80D	2-1/2	LHS3D
LHS88D	2-3/4	LHS3D
LHS96D	3	LHS3D
LHS128D	4	LHS3D
LHS184D	6	LHS3D

LHS608B[‡] 9 pc Hole Saw and Arbor Kit

- Side slits make it easy to knock out the spent disks
- Includes LHS44D, LHS48D, LHS56D, LHS64D, LHS80D, LHS96D hole saws, LHS6C and LHS3D arbors, LHS8C arbor adaptor and recommended speed chart in a storage case

LHS606D[‡] 7 pc Hole Saw and Arbor Kit

- Side slits make it easy to knock out the spent disks
- Includes LHS24D, LHS28D, LHS32D, LHS36D, LHS40D hole saws, LHS6C arbor, LHS8C arbor adaptor and recommended speed chart in a storage case

HOLE SAWS

Hole Saw Arbors and Pilot Drills

Stock No.	Thread Size	Fits Saws, inches	Fits Drill Chucks, inches	Replacement Pilot Drill
LHS5C	1/2"-20	9/16-1-3/16	1/4	LHS4D
LHS6C	1/2"-20	9/16-1-3/16	3/8	LHS4D
LHS1C	1/2"-20	9/16-1-3/16	1/2	LHS4D
LHS3D	5/8"-18	1-1/4-6	3/8	LHS4D
LHS8C	Arbor Adaptor to Convert 1/2"-20 Thread to 5/8"-18			



DRILLING ACCESSORIES



YA246A

YA246A[†] 13 pc Micro Utility Drill Set (Blue-Point®)

- Knurled surface at the chuck end of the pin vise provides a sure gripping surface
- Long 1-7/8" drill length
- Includes pin vise and (12) precision HSS twist drills from .0635-.0225", numbers 52-74

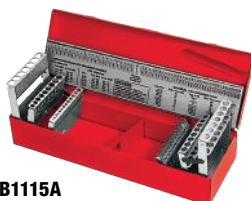

B1115A

B1115A Metal Drill Bit Index

- Clearly marked trays hold 115 drill bits and lift to upright position for quick selection
- 14-1/8 L x 4-1/8 W x 2-1/2" D



DEBUR300

DEBUR300 Deburring Tool

- Easily deburrs drilled and machined holes
- Push-button locking collet enables quick, easy blade changes
- Includes (3) round-head deburring blades
- Blades store in the handle of tool
- 6" long



RM125



RM150



RM250

RM125 1/8-3/8" Hex Drive Tapered Reamer

- Compact 3-5/8" length profile provides access to tight locations
- Tough high-speed steel construction with precision cut edges for long life—can be resharpened
- Unique hex-profile for multiple means of use: RMT1 T-Bar (included), socket or palm ratchet
- Each size has an overlap for the largest diameter to the tip of the next reamer size to maintain seamless transitions
- Made in USA

RM150 1/4-9/16" Hex Drive Tapered Reamer

- Same features as the RM125
- Unique hex-profile for multiple means of use: RMT2 T-Bar (included), socket or palm ratchet

RM250 1/2-3/4" Hex Drive Tapered Reamer

SANDER ACCESSORIES

14.4 V MicroLithium Polishing/Prep Tools

Stock No.	Description	Stock No.	Description
ACR2ALUM36	2" ROLOC® Abrasive Disc	ACR3HOLDER	3" ROLOC® Disc Holder
ACR2ALUM80	2" ROLOC® Abrasive Disc	ACR3MEDIUM	3" Medium Surface Prep Disc
ACR2CLEAN	2" Crud Disc	CTPP761-900	Disc Pad
ACR2CORSE	2" Coarse Surface Prep Disc	CTPP761-903	3" Knit Buffing Pad
ACR2HOLDER	2" ROLOC® Disc Holder	CTPP761-904	3" Sanding Disc, 36 Grit
ACR2MEDIUM	2" Medium Surface Prep Disc	CTPP761-905	3" Sanding Disc, 80 Grit
ACR3ALUM36	3" ROLOC® Abrasive Disc	CTPP761-906	2" ROLOC® Blocking Pad
ACR3ALUM80	3" ROLOC® Abrasive Disc	CTPP761-907	2" ROLOC® Medium Surface Disc
ACR3CLEAN	3" Crud Disc	CTPP761-950	Disc Pad Wrench
ACR3CORSE	3" Coarse Surface Prep Disc	CTPP761-951	ROLOC® Adaptor



ACR2ALUM36

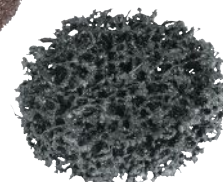

ACR2CLEAN



†These products can expose you to chemicals which are known to the state of California to cause cancer and reproductive harm. See pages P1-P2 for details.
• Read Safety Precautions on pages W1-W4

SANDER ACCESSORIES



AT401ACCKIT

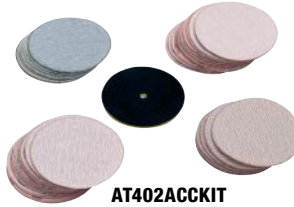

AT402ACCKIT



AT403ACCKIT

Micro Tool Accessory Kits

AT401ACCKIT Micro Surface Prep Accessory Kit (Blue-Point®)

- 1/4 turn abrasive disc in two different grits helps get the job of removing rust or gasket material done quickly, even in confined areas
- Kit contains all of the consumables needed to restore a Micro Surface Prep Tool Kit back to new
- Includes (1) 2" ROLOC® pad 1/4" x 20T, (1) 3" ROLOC® pad 1/4" x 20T, (5) 2" 40 grit pads and (5) 3" 80 grit pads

AT402ACCKIT Micro Dual Action Sander Accessory Kit (Blue-Point®)

- Fresh backing pad with all the sanding disc needed to work the surface down until it is ready for paint
- Kit contains all of the consumables needed to restore a Micro Dual Action Sander Tool Kit back to new
- Includes (1) 3" hook-and-loop pad 5/16" x 24T, (25) 3" 180 grit pads, (25) 3" 220 grit pads, (10) 3" 320 grit pads and (10) 3" 800 grit pads

AT403ACCKIT Micro Polisher Accessory Kit (Blue-Point®)

- All the pads needed to go from buffing to final polish
- Kit contains all of the consumables needed to restore a Micro Polisher Tool Kit back to new
- Includes (1) 3" hook-and-loop pad 5/16" x 24T, (1) 3" wool pad and (1) foam waffle pad



PS4312-1H

PS4612V-1AH

PS468-34V



AT406CVAC

PSV4312KIT

YA7341

YA7341⁺ Bonnet Cleaning Tool

- Run the spur wheels over a buffing pad or bonnet to dislodge and remove dry, hardened polish

GO459-39 Vacuum Adaptor

- Vacuum adaptor for PS4609 and PS4809

Tune-up Kits

PS46-TKA Tune Up Kit

- For PS4612/PS4512 series orbital sanders

Replacement Sander Pads

Stock No.	Size, inches	Type	Style	Use on
PS4312-1H	3	PSA	Vacuum/Non-Vacuum	PSF4312
PS4512-1AH	5	PSA	Non-Vacuum	PS4512
PS4512V-1AH	5	PSA	Vacuum	PS4512
PSO4525-2H	5	Velcro® Brand fasteners	Non-Vacuum	PS4512
PS4512V-2H	5	Velcro® Brand fasteners	Vacuum	PS4512
PS4612V-1AH	6	PSA	Vacuum	PS4612 and PSF4612
PSO4625-2H	6	Velcro® Brand fasteners	Non-Vacuum	PS4612 and PSF4612
AT116-4	6	Velcro® Brand fasteners	Vacuum	PS4612 and PSF4612
PS468-34	6	PSA	Non-Vacuum	PS4609
PS468-34V	6	PSA	Vacuum	PS4609V
PSG468-34HL	6	Velcro® Brand fasteners	Non-Vacuum	PS4609
PS468-34VHL	6	Velcro® Brand fasteners	Vacuum	PS4609V
PS468-35	8	PSA	Non-Vacuum	PS4809
PS468-35V	8	PSA	Vacuum	PS4809V
AT116-3	2	Roloc®	Non-Vacuum	AT401MCA
AT116-4	3	Roloc®	Non-Vacuum	AT401MCA
AT402VEL75MM	3	Hook-and-loop	Non-Vacuum	AT402MCA and AT403MCA
AT406C-27	4	Hook-and-loop	Non-Vacuum	AT406C
PSO4325-2H	3	Velcro® Brand fasteners	Vacuum/Non-Vacuum	PSF4312

Vacuum Adaptor Kits (contains vacuum adaptor and shroud)

Stock No.	Type	Use on
AT406CVAC	Vacuum Kit (AT406C) (Blue-Point®)	AT406C
PSV4312KIT	Vacuum Kit for 3" Sanders	PSF4312

WIRE BRUSHES/FLAP WHEELS (Blue Point®)



Description	Stock No.	Brush Diameter, inches	Shank Size, Arbor Size	Wire Diameter, inches	Maximum Safe Free Speed, RPM
Crimped Wire Brush (Blue-Point®) Crimped for removing carbon from cylinder heads and valve parts	AC2D [‡]	1	1/4	.020	20,000
	AC3D [‡]	3/4	1/4	.020	20,000
Solid End Wire Brush (Blue-Point®) Solid end for cleaning aluminum cylinder heads and transmission parts	AC16D [‡]	3/4	1/4	.006	20,000
Spiral Twist Wire Brush (Blue-Point®) Spiral twist for removing heavy deposits	AC6B [‡]	3/4	1/4	.014	20,000
	AC7E [‡]	1	1/4	.020	20,000
Cup-Type Wire Brush (Blue-Point®) Cup-Type for cleaning wheel rims and scuffing tires	AC240B [‡]	1-3/4	1/4	.012	6,000
Hollow End Crimped Cup Wire Brush (Blue-Point®) Hollow End crimped cup for light-duty cleaning	AC241B [‡]	2-1/2	1/4	.012	6,000
Cup Flared Wire Brush (Blue-Point®) Cup flared for deburring, cleaning hard-to-reach areas and wheel rims, and scuffing tires	AC208A [‡]	1-1/2	1/4	.008	20,000
	AC212A [‡]	1-1/2	1/4	.012	20,000
	AC214A [‡]	2-1/2	1/4	.014	18,000
	AC224A [‡]	3	1/4	.014	15,000
Encapsulated Wire End Wire Brush (Blue-Point®) Encapsulated Wire End Wire Brushes for a consistent stiff brushing action	AC204C [‡]	1/2	1/4	.014	8,000
	AC205C [‡]	3/4	1/4	.014	8,000
	AC206C [‡]	1	1/4	.014	8,000
Single Row Knot-Type Wire Brush (Blue-Point®) Knot-type, single-row wire cup for heavy-duty surface application	AC339A [‡]	3	5/8-11	.020	12,500
	AC341B [‡]	3	5/8-11	.012	7,000
	AC342B [‡]	4	5/8-11	.020	7,000



General Purpose

Description	Stock No.	Brush Diameter, inches	Shank Size, Arbor Size	Wire Diameter, inches	Maximum Safe Free Speed, RPM
Knotted Wire Wheel Brush (Blue-Point®) Heavy-duty cleaning	AC420A [‡]	4	5/8-11	.020	20,000
Crimped Wire Wheel (Blue-Point®) General-purpose cleaner	AC616 [‡]	3	1/4	.0118	20,000
Wire Brush (Blue-Point®) Medium-duty general cleaner	AC17D [‡]	1	1/4	.006	20,000
	AC243 [‡]	3	5/8-11	.014	14,000
End Brush (Blue-Point®) Ideal for cleaning right angles	AC10302 [‡]	1/2	1/4	.014	25,000
	AC10306 [‡]	3/4	1/4	.014	22,000

A24C Arbor, 1/4" Shank, 1/2" Arbor Adaptor (Blue-Point®)

- Adapts electric drill to light-duty grinding and wire brushing: use with wheels and brushes up to 4" in diameter
- 1/4" shank, 1/2" diameter arbor, 1-3/4" length
- 20,000 RPM maximum speed

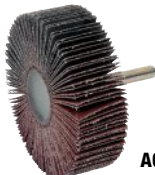

AC3160FWMP

AC3160FWMP[‡] Flap Wheel (Blue-Point®)

- 3" dia., 60 grit, (10 pack)



ACMANDREL

ACMANDREL Mandrel

- 1/4" stem for use on 2" and 3" flap discs



AC4D

AC4D[‡] Brush



AC239

AC239[‡] 1-1/2" Crimped Cup

- Do not operate without the guard.
- Do not use grinding discs or accessories above their rated RPM.
- Do not use sanding discs or accessories above their maximum rated RPM.
- Do not use wire brushes above their maximum rated RPM.
- Do not use power tool accessories above their maximum rated RPM

[‡]These products can expose you to chemicals which are known to the state of California to cause cancer and reproductive harm. See pages P1-P2 for details.

- Read Safety Precautions on pages W1-W4



CUTTING AND GRINDING ACCESSORIES



ETA125A

ETA125A[†] Grinding Wheel Set

- Use with ET1350/ET1360
- 12,000 RPM maximum speed
- 5 pk



AT154RWHLMPA

AT154RWHLMPA[†] 4" Cutting Wheel (Blue-Point®)

- Aluminum-oxide cutting wheel for all metal types
- 4" dia. with a 3/8" arbor hole
- 21,000 RPM maximum speed



AT215GWSETA

AT215GWSETA 6 pc 2" Grinding Wheel Set (Blue-Point®)

- Replacement grinding wheels for the AT215 angle grinder
- 20,000 RPM maximum speed
- 6 pk



ETA250A

ETA250A[†] Grinding Wheel Set (Blue-Point®)

- 1/4 x 4-1/2 x 7/8"
- Coarse 24 grit
- 12,000 RPM maximum speed



AT415-20B

AT415-20B[†] Grinding Disc

- For the AT415B grinder
- 4" dia. x 3/16" thick with a 5/8" arbor hole
- 12,000 RPM maximum speed
- 5 pk

CARBIDE BURRS



VWB800D



VWB400A



VWBL400



VWB200C

Grinding burrs are ideal for use with Snap-on® die grinders. 1/4" and 1/8" shank burrs are available, all with solid carbide heads. The 1/8" shank units all have a maximum head diameter of 1/8".



Carbide Burrs, 1/4" Shank

	Stock No.	Style (chart)	Shank Length, inches	Flute Length, inches	Head Dia., inches	Recommended RPM Cast Iron	Recommended RPM Stainless				
Carbide Burrs, 1/4" Shank	VWB1C	A	—	5/8	1/4	22,000	23,000	•	•		
	VWB9B	A	—	1	1/2	16,000	24,000				
	VWB2B	B	—	3/4	3/8	18,000	27,000	•	•		
	VWB10B	B	—	1	1/2	16,000	24,000				
	VWB3B	C	—	1/4	5/16	20,000	30,000	•			
	VWB4B	D	—	7/8	1/2	16,000	24,000	•			
	VWB11B	E	—	3/4	3/8	18,000	27,000				
	VWB5B	E	—	1	1/2	16,000	24,000	•	•		
	VWB6B	F	—	3/4	3/8	18,000	27,000	•			
	VWB7B	G	—	1-1/8	1/2	16,000	24,000	•	•		
	VWB12B	G	—	1-1/16	3/8	18,000	27,000				
	VWB8B	H	—	7/8	1/2	16,000	24,000	•			
Long-Reach Carbide Burrs, 1/4" Shank	VWBL401	—	4	—	3/8	14,000	17,000				•
	VWBL402	—	4	—	3/8	14,000	17,000				•
	VWBL403	—	4	—	3/8	14,000	17,000				•
	VWBL404	—	4	—	3/8	14,000	17,000				•
Wide Fluted Carbide Burrs, 1/4" Shank	VWB206C	A	—	1	1/2	15,000	25,000				•
	VWB204C	A	—	3/4	1/4	15,000	25,000				•
	VWB203C	B	—	1	1/2	15,000	25,000				•
	VWB202C	E	—	1	1/2	15,000	25,000				•
	VWB201C	G	—	1-1/8	1/2	15,000	25,000				•
	VWB205C	G	—	1-1/16	3/8	15,000	25,000				•

Set Contains:
 VWB800D
 VWB400A
 VWBL400
 VWB200C

CARBIDE BURRS



Carbide Burrs, 1/8" Shank

Set Contains:

Stock No.	Style (chart)	Flute Length, inches	Recommended RPM Cast Iron	Recommended RPM Stainless	
VWB301B	A	9/16	20,000	75,000	•
VWB302B	B	9/16	20,000	75,000	•
VWB303B	C	1/8	20,000	75,000	•
VWB304B	D	7/32	20,000	75,000	•
VWB305B	E	1/2	20,000	75,000	•
VWB306B	F	3/8	20,000	75,000	•
VWB307B	G	1/2	20,000	75,000	•
VWB308B	H	7/16	20,000	75,000	•

AIR HAMMER ACCESSORIES



Air Hammer Bit Sets

Set Contains:

Stock No.	Description	Applications	Length, inches	Tip, inches			
PHG63B	Air Hammer Ball Joint/Tie Rod Separator	Separating Ball Joints and Tie Rods	7-3/8	13/16 Opening			
PHG69B	Air Hammer Ball Joint/Tie Rod Separator	Separating Ball Joints and Tie Rods	7-3/8	1 Opening			
PHG93B	Ball Joint/Tie Rod Separator	Separating Ball Joints and Tie Rods	8-3/4	1-1/4 Opening			
PHG94B	Ball Joint/Tie Rod Separator	Separating Ball Joints and Tie Rods	7-3/8	5/8 Opening			
PHG64B	Air Hammer Bent End Chisel	Shears Ball Joint Rivets	10-1/2	5/8			
PHG76B	Bushing Cutter	Bushing Cutting	6-1/4	1/2			
PHG21B	Offset Bushing Splitter	Bushing Cutting (Extra Reach)	8-3/8	5/8			
PHG85B	Air Hammer Curved Flat Chisel	Rivet Cutting Work	5-3/4	5/8			
PHG57B	Air Hammer Double-Bladed Panel Cutter	Panel Cutting and Sheet Metal Cutting	6	3/4	•	•	
PHG73B	Air Hammer Drift Punch	Punching Out Pins and other Driving Applications	6-1/2	1/2		•	•
PHG77B	Straight Punch	Punching Out Pins and other Driving Applications (Extra Reach)	18	1/2			
PHG55B	Air Hammer Flat Chisel	Normal Chisel Cutting Applications	6-1/2	3/4	•	•	•
PHG58C	Air Hammer Flat Chisel	Normal Chisel Cutting Applications that need Extra Reach	10	3/4			•
PHG84B	Flat Chisel	Standard Chisel Cutting Applications (Extra Reach)	18	3/4			
PHG99B	Air Hammer Flat Chisel	Standard Chisel Cutting Applications (Extra Reach)	6-1/2	1-1/2			
PHG111B	Hinge Pin Driver	Removing and Installing Tube-Hinge Pins on Car and Truck Doors	7-3/8	0.237			
PHG112B	Hinge Pin Driver	Removing and Installing Tube-Hinge Pins on Car and Truck Doors	7-3/8	0.302			
PHG95B	Hole Punch	Punches 3/16" dia. Starting Hole in Sheet Metal to prepare use with CJ107 and CJ114 Body Dent Pullers	5-5/8	—			
PHG65B	Outside Muffler Cutter	For cutting the muffler flange	8-5/8	7/8			
PHG66B	Inside Muffler Cutter	Cutting the Exhaust Pipe Inside the Flange	8-3/4	3/16			
PHG87B	Muffler Cutter	Removing the Tail Pipe	8-3/4	7/8			
PH201	Needle Scaler	Projecting Rods Chip Away Rust and Scale. Use Only at Low-Pressure	7-13/16	—			
PHG74B	Riveter	3/16" Stem	5-13/16	1/2			
PHG75B	Pneumatic Bearing and Bushing Driver	Pneumatic Bearing and Bushing Driver	5-1/2	1/2			

- Do not operate without the guard. • Do not use grinding discs or accessories above their rated RPM.
- Use air hammer accessories only for their intended purpose. • Do not use chipped or damaged accessories.
- Do not use grinder accessories beyond their maximum rated RPM.
- Do not use wire brushes above their maximum rated RPM.
- ‡ These products can expose you to chemicals which are known to the state of California to cause cancer and reproductive harm. See pages P1-P2 for details.
- Read Safety Precautions on pages W1-W4



AIR HAMMER ACCESSORIES

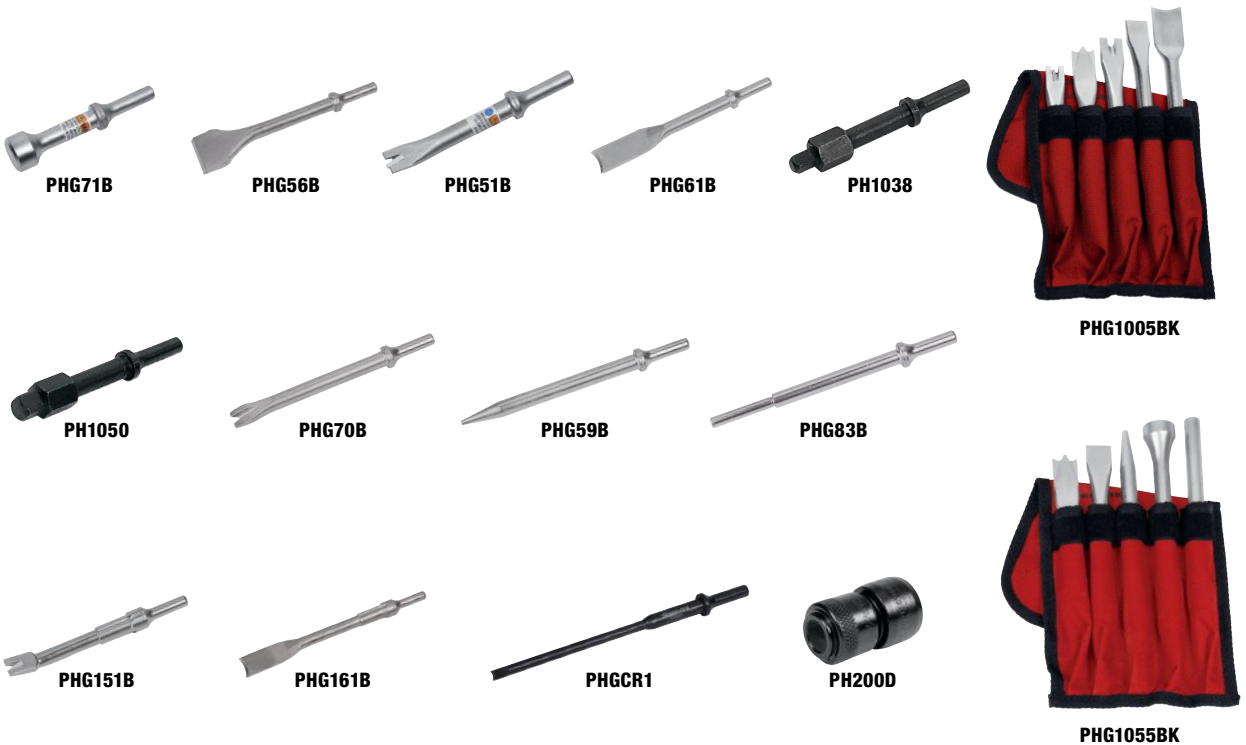

Stock No.	Description	Applications	Length, inches	Tip, inches			
PHG78B	Riveter	1/4" Stem	5-3/4	1/2			
PHG88B	Air Hammer Riveter	Forming Heads on 3/16" Compression Rivets	5-13/16	1/2			
PHG89B	Riveter	Forming Heads on 1/4" Compression Rivets	3-7/8	7/8			
PHG71B	Round Hammer	Hammering Applications that need Extra Reach	4-1/4	1			•
PHG68B	Round Hammer	Hammering Applications	7	1			• •
PHG56B	Air Hammer Scraper	Scraping Applications	6-3/16	1-5/16			
PHG51B	Air Hammer Sheet Metal Ripper	Sheet Metal Ripping and Cutting	5-3/8	5/8	•		
PHG61B	Air Hammer Slitting Chisel	Cutting Tail Pipes and other Surfaces	6-7/8	1	•		
PH1038	3/8" Square Drive Air Hammer Socket Adaptor (Blue-Point®)	Attaches to Air Hammer to Provide Vibration While Turning Stubborn Fasteners, 3/4" Hex, 3/8" Square Drive	5	—			
PH1050	1/2" Square Drive Air Hammer Socket Adaptor (Blue-Point®)	Attaches to Air Hammer to Provide Vibration While Turning Stubborn Fasteners, 3/4" Hex, 1/2" Square Drive	5	—			
PHG70B	Air Hammer Spot Weld Breaker	Weld Removal	6-1/4	3/4	•		
PHG59B	Air Hammer Tapered Punch	Removal of Pins	6-1/2	3/16			• •
PHG72B	Air Hammer U-Joint Needle Type Trunion Driver	Needle Type Trunions	3-7/8	7/8			
PHG83B	Valve Guide Remover	Removing and Installing Valve Guides	7.48	7.7 mm Pilot			
PHG86B	Valve Guide Remover	Removing and Installing Valve Guides	7.48	9.3 mm Pilot			
PHG91B	Valve Guide Remover	Removing and Installing Valve Guides	7.4	6.5 mm Pilot			
PHG96B	Valve Guide Remover	Removing and Installing Valve Guides	7.4	6.9 mm Pilot			
PHG97B	Valve Guide Remover	Removing and Installing Valve Guides	7.4	5.5 mm Pilot			
PHG151B	Panel Cutter	Edges and Trims Sheet Metal. Cutting End is Offset 25° Non-Turn Shank	6-7/8	5/8			
PHG161B	Slitting Chisel	Cuts Exhaust System Pipes, 1/8" Tip Thickness. Non-Turn Shank	8-3/4	1			
PHG155B	Air Hammer Cold Chisel	Cuts Bolts, Nuts, Tees and Angles; Splits and Bevels, Non-Turn Shank	7	21/32			
PHGCR1 [†]	Front Axle C-Clip Remover	Tire and Wheel: Removes C-Clips stuck in place by rust, cup shift, dirt and grime, for use on Ford®, GM® and Dodge® vehicles as well as any vehicle that uses a U-Joint with C-Clip retainer	—	—			
PH200D	Universal Quick-Change Chuck Retainer	Use for Fast, Easy Insertion/Removal of Air Hammer Bits	—	—			

Set Contains:
 PHG1005BK
 PHG1055BK
 PHG1066BK

Air Hammer Bit Sets

PHG1540K[‡]

Stock No.	Description	
PHG1540-6 [‡]	6" Hammer Shaft	•
PHG1540-9 [‡]	9" Hammer Shaft	•
PHG1540-18 [‡]	18" Hammer Shaft	•
PHG1540-ALM [‡]	Aluminum Hammer Head	•
PHG1540-NYL [‡]	Nylon Hammer Head	•
PHG1540-STL [‡]	Steel Hammer Head	•
PHG1540-BAG [‡]	Hammer Set Canvas Pouch	•

Includes kit bag

PHG1540K[‡] 6 pc Interchangeable Tip Air Hammer Bit Set

- Three (3) shafts in different lengths make accessing hard-to-reach places safer and easier
- Quick-change head design with (3) tips (steel, aluminum, nylon)
- Ability to choose the appropriate hammer head material to reduce damage to vulnerable areas
- Worn-out tips are easily replaceable



PHG1540K

Roll Pin Punches

Set Contains:

PHG1004RPBK

Stock No.	Description	Applications	Length, inches	Tip, inches	
PHG79B	Roll Pin Punch	For Removing and Installing Roll Pins	7-1/2	3/8	•
PHG80B	Roll Pin Punch	For Removing and Installing Roll Pins	7-1/2	1/4	•
PHG81B	Roll Pin Punch	For removing and installing roll pins	7-1/2	5/16	•
PHG821B	Roll Pin Punch	For Removing and Installing Roll Pins	7-1/2	1/2	•

Includes kit bag



PHG1004RPBK

Extra-Long Drift Punches (Blue-Point®)

Set Contains:

PHGL37KT

Stock No.	Description	Application	Length, inches	Size, inches (mm)	
PHGL78 [‡]	Extra-Long Drift Punch (Blue-Point®)	Loosens Hard-to-Reach Rusty Bolts and Fasteners	5	5/16 (8)	•
PHGL710 [‡]	Extra-Long Drift Punch (Blue-Point®)	Loosens Hard-to-Reach Rusty Bolts and Fasteners	5	3/8 (10)	•
PHGL712 [‡]	Extra-Long Drift Punch (Blue-Point®)	Loosens Hard-to-Reach Rusty Bolts and Fasteners	5	1/2 (12)	•

PHGL37-KB Kit includes storage pouch.



PHGL37KT

- Use air hammer accessories only for their intended purpose.
- Do not use chipped or damaged accessories.
- Do not use grinder accessories beyond their maximum rated RPM.
- Do not use wire brushes above their maximum rated RPM.
- Do not use power tool accessories above their maximum rated RPM

[‡]These products can expose you to chemicals which are known to the state of California to cause cancer and reproductive harm. See pages P1-P2 for details.

- Read Safety Precautions on pages W1-W4



IMPACT WRENCH AND RATCHET ACCESSORIES



YA4190A



YA4190CAPA



YA4190FAR



YA4190DIS

YA4190A Mini Grease Gun

- Fits all flush-type fittings
- Ideal for all FAR Series air ratchets
- Spring return plunger
- 3 oz capacity

YA4190CAPA Grease Gun Head

- Fits YA4190A mini grease gun

YA4190FAR Grease Gun Assembly

- Use with FAR series air ratchets

YA4190DIS Grease Dispenser (Blue-Point®)

- Grease dispenser attachment for YA4190A mini grease gun
- Contains 3 oz of Mobil® temp SHC-32 grease for Snap-on® FAR Series air ratchets



AT123-7-100



AT123-16-100

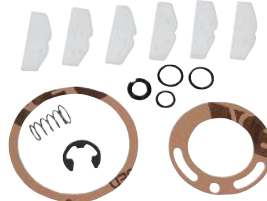

AT123-18-100



MG31MKIT

MG725MKIT

AT123-7-100 7 pc Hammer and Anvil Tune-up Kit

- Use on AT123A only
- Symptoms indicating repair is needed include air motor spins but anvil does not turn, air motor spins and anvil turns but no impacting occurs, or tools stalls while impacting

AT123-16-100 19 pc Tune-up Kit

- Use on AT123A and AT123AL
- Symptoms indicating repair is needed include trigger does not work properly or air leaks while tool is idle or running

AT123-18-100 15 pc Tune-up Kit

- Use on AT123A and AT123AL
- Symptoms indicating repair is needed include trigger does not work properly, air leaks while tool is idle or running, air motor has reduced RPM or air motor is excessively noisy

MG31MKIT Muffler Kit MG725MKIT Muffler Kit

- Reduces noise level to below 85 dBa
- Installs in minutes
- Maximum torque with muffler is 250 ft-lb (339 N•m)
- OSHA® compliant for 8 hours of continuous use



QC3ALC

QC3825

QC3844

QC5044

Impact Wrench Accessories

Stock No.	Description	Overall Length, inches (cm)	Weight, oz (grams)
QC3ALC	3 pc Quick-Change Adaptor Set	—	—
QC3825	3/8" Square to 1/4" Hex Adaptor	1-1/2 (3.8)	2.1 (60)
QC3844	3/8" Square to 7/16" Hex Adaptor	1-3/4 (4.5)	3.7 (104)
QC5044	1/2" Square to 7/16" Hex Adaptor	1-7/8 (4.75)	4.3 (124)

Air Saw Blades

Stock No.	Application/Material Thickness	Teeth Per Inch (TPI)	Length, inches	Blade Thickness, inches (mm)	Quantity
ASB4-42	Over 0.20"	18	3-5/8	.025 (.63)	10 Each
ASB4-43	0.08-0.20"	24	3-5/8	.025 (.63)	10 Each
ASB4-44	0.00-0.08"	32	3-5/8	.025 (.63)	10 Each



ASB4-42

Air Saw Blades

Stock No.	Description	Length, inches	Teeth Per Inch (TPI)	Blade Thickness, inches (mm)	Package Quantity
AT190-39C	Bi-Metal Blade Scroll (Blue-Point®)	3-3/4	18	.035 (.89)	5
AT190-40C	5 pk 3-3/4" Bi-Metal Scroll Air Saw Blades (Blue-Point®)	3-3/4	24	.035 (.89)	5
AT190-41C	Bi-Metal Blade Scroll (Blue-Point®)	3-3/4	32	.035 (.89)	5
AT190-42B	Bi-Metal Blade Multipurpose (Blue-Point®)	4	18	.035 (.89)	5
AT190-43B	5 pk 4" Bi-Metal Multipurpose Air Saw Blades (Blue-Point®)	4	24	.035 (.89)	5
AT190-44B	Bi-Metal Blade Multipurpose (Blue-Point®)	4	32	.035 (.89)	5



AT190-42B

Metal Cutting Blades

Stock No.	Application/Material Thickness	Teeth Per Inch (TPI)	Blade Thickness, inches (mm)	Blade Length, inches (mm)	Quantity
CTRS614MC	Metal 1/8-3/8" Thick	14	.035 (.89)	6 (152)	5 Each
CTRS618MC	Metal 1/8-1/4" Thick	18	.035 (.89)	6 (152)	5 Each
CTRS624MC	Metal Less Than 1/8" Thick	24	.035 (.89)	6 (152)	5 Each
CTRS914MC	Metal 1/8-3/8" Thick	14	.035 (.89)	9 (229)	5 Each
CTRS918MC	Metal 1/8-1/4" Thick	18	.035 (.89)	9 (229)	5 Each
RSB424PM	Precision Metal Cutting	24	.035 (.89)	4 (102)	5 Each
RSB418PM	Precision Metal Cutting	18	.035 (.89)	4 (102)	5 Each
RSB6812JY	High-Strength Metal	8/12	.050 (1.27)	6 (152)	5 Each
RSB9812JY	High-Strength Metal	8/12	.050 (1.27)	9 (229)	5 Each



CTRS614MC



RSB418PM

General Purpose Blades

Stock No.	Application/Material Thickness	Blade Length, inches (mm)	Material Thickness	Teeth Per Inch (TPI)	Blade Thickness, inches (mm)	Quantity
CTRS126GP	Metal/Plastic/Wood	12 (305)	3/8-2"	6	.050 (1.27)	5 Each
CTRS658GP	Metal/Plastic/Wood	6 (152)	3/8-2"	5-8 Variable	.050 (1.27)	5 Each
CTRS96GP	Metal/Plastic/Wood	9 (229)	3/8-2"	6	.050 (1.27)	5 Each
RSB911WP	General Purpose Wood/Plastic	9 (229)	5/32-1-5/32"	11	.04 (1)	5 Each
RSB97WB	Fast Cutting Wood 3/8" and Thicker	9 (229)	—	7	.040 (1.01)	5 Each



CTRS126GP

Wood Cutting Blades

Stock No.	Application/Material Thickness	Teeth Per Inch (TPI)	Blade Thickness, inches (mm)	Blade Length, inches (mm)	Quantity
CTRS67WB	Fast Cutting Wood 3/8" and Thicker	7	.040 (1.01)	6 (152)	5 Each
RSB97WP	Fast Cutting Wood 3/8" and Thicker	7	.040 (1.01)	9 (229)	5 Each



CTRS67WB



- Use only impact sockets and accessories with air ratchets.
- Use air hammer accessories only for their intended purpose.
- Do not use chipped or damaged accessories.
- Read Safety Precautions on pages W1-W4

BLOW GUNS

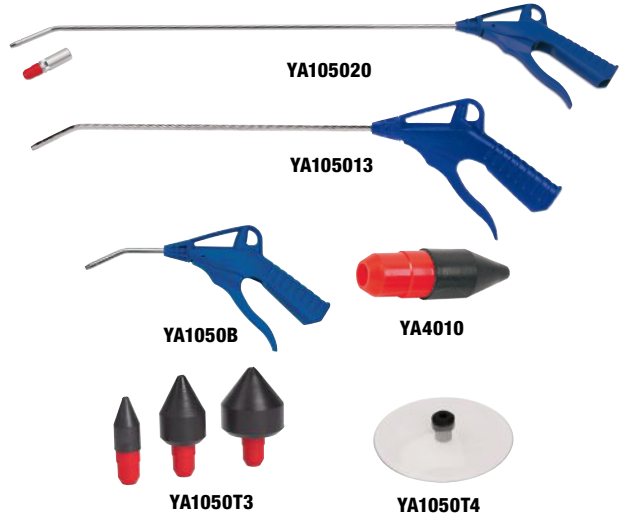

Non-Vented Blow Guns

AT4113 19" Straight Tube Air Blow Gun

- Built-in valve system improves trigger control
- Impact-resistant material for long-lasting service
- Galvanized blow tube for corrosion resistance
- Lifetime warranty (accessories not included)
- Used for blowing off, cleaning and drying surfaces
- Used in any sector of industry where compressed air is used

AT4112B 300 mm Bent Tube Blow Gun

- Built-in valve system improves trigger control
- Impact-resistant material for long-lasting service
- Galvanized blow tube for corrosion resistance
- Lifetime warranty (accessories not included)

AT4101* 4" Blow Gun

- Built-in valve system improves trigger control
- Impact-resistant material for long-lasting service
- Galvanized blow tube for corrosion resistance
- Lifetime warranty (accessories not included)

AT4135 Blow Gun with Air Adjustment

- Built-in valve system improves trigger control
- Impact-resistant material for long-lasting service
- Galvanized blow tube for corrosion resistance
- Lifetime warranty (accessories not included)
- Sound level 78 dB (8 bar)
- Regulate flow with adjustable volume control
- Complies with OSHA® safety standards
- Used for blowing off, cleaning and drying surfaces
- Used in any sector of industry where compressed air is used

AT4124 Rubber Tip

- Prevents scratching of surface
- Used with AT4101, AT4113 and AT4135 air blow guns

AT4164* Rubber Blow Gun Tip

- Rubber tip prevents scratching of delicate surfaces
- Push-to-connect collar holds tip securely onto the blow gun pipe
- Tip is easily removed from the blow gun pipe by simply pulling back on the collar
- 25 mm tip diameter is ideal for flushing hoses up to 7/8"
- Tip works with AT4101, AT4113 and AT4112 blow gun models
- Lifetime warranty

Non-Vented Blow Guns (Blue-Point®)

YA105020* 20" Bent Nozzle Blow Gun (Blue-Point®)

- 20" bent nozzle
- Trigger provides variable airflow control
- Lightweight body with ergonomically designed grip provides comfort and control
- Venturi tip directs air sideways if the tip end is obstructed
- Reinforced 1/4"-18 NPT inlet

YA105013* Blow Gun (Blue-Point®)

- Same as YA105020 except 13" bent nozzle
- YA1050T2* Venturi Air Booster (Blue-Point®)**
- Venturi nozzle draws in ambient air for extra high-flow (increasing by 100%)
 - Suitable for deflecting lightweight wood chips
 - Diverts air when dead-ended, reducing the outlet pressure to less than 2 bar (29 PSI)

YA1050B* Blow Gun (Blue-Point®)

- Pistol-grip-style with full-sized front trigger
- Infinite variable flow
- 10-1/4" long

YA4010* Quick Change Rubber Tip (Blue-Point®)

- Conical rubber tip for YA1050B Blow Gun

YA1050T3* 3 pc Rubber Tip Kit (Blue-Point®)

- Rubber tip kit for YA105020 Blow Gun

YA1050T4* Chip/Fluid Shield (Blue-Point®)

- Chip/fluid shield for YA105020 Blow Gun



AT144800

Non-Vented Blow Guns Accessories

AT144800 5 pc Blow Gun Nozzle Kit

- Not for use above 30 PSI air supply pressure.

Colors Available



* ADD SUFFIX TO STOCK NUMBER FOR SPECIAL COLORS.



Vented Blow Guns

AT4190* HI-FLO Venturi Tip Blow Gun

- Large diameter venturi nozzle draws in ambient air and increases output volume by 100%
- Nozzle delivers up to 21 CFM
- Ideal for heavy-duty chip and debris removal
- Excellent tool to quickly dry vehicles or motorcycles
- OSHA® compliant
- 1/4"-18 FNPT inlet
- Lifetime warranty

YA1055B† Blow Gun (Blue-Point®)

- Variable-flow trigger offers precise airflow control
- Six-outlet star tip delivers an even distribution of air
- 4" full-flow tube
- OSHA® compliant
- Air inlet: 1/4"-18 NPT(f)

JT13B Blow Gun (Blue-Point®)

- Tapered, rubber tip for a leak-proof connection between the gun and the fluid line
- Vinyl-coated control lever
- Hanging hook for storage
- 4-1/2" long

JT17A Blow Gun (Blue-Point®)

- Same as JT13B except with 3" extension in place of the rubber tip

JT19A Venturi Tip Blow Gun (Blue-Point®)

- Directs air sideways if tip end becomes obstructed
- Venturi tip increases airflow
- Includes stabilizer valve for variable pressure
- 1" hanging hook and paddle type air control lever
- Air inlet: 1/4"-18 NPT(f)
- OSHA® compliant

Colors Available



ADD SUFFIX TO STOCK NUMBER FOR SPECIAL COLORS.

AIR WATER WASHERS



Water Nozzles and Hoses

JETWASHER Air Water Jet Washer

- Combines compressed air and water to create a powerful jet washer
- Provides safe and effective cleaning
- Separate air and water controls
- Multifunction—rinse, clean or dry with air and water
- Wide nozzle design prevents splash-back
- Lightweight and compact

- Durable nylon components will not scratch surfaces
- Includes a 3/4" threaded garden hose connection and quick-connect adaptor
- Optional stepped nozzle can be used to flush coolant systems and heater cores

JETWASHFAN Jet Washer Fan Nozzle

JETWASHNOZL Jet Washer Flushing Nozzle (Optional)

- Do not use vented blow guns above 135 PSI air supply pressure.
- Do not use non-vented blow guns above 30 PSI.
- Do not direct blow gun at yourself or others.
- Wear protective gloves.

†These products can expose you to chemicals which are known to the state of California to cause cancer and reproductive harm. See pages P1–P2 for details.
• Read Safety Precautions on pages W1–W4



AIR HOSES AND SWIVELS



IM2005A

Air Hoses, Rubber

- Ideal for industrial applications
- Male threads at both ends

Stock No.	Hose I.D., inches	Hose Length, feet	Thread Size	Maximum Pressure, PSI
IM2001A [‡]	1/4	5 whip	1/4"-18 NPT	300
IM2002A [‡]	3/8	5 whip	1/4"-18 NPT	300
IM2004A [‡]	3/8	2 whip	1/4"-18 NPT	300
IM2005A [‡]	3/8	25	1/4"-18 NPT	325
IM2008A [‡]	3/8	50	1/4"-18 NPT	325
IM2009A [‡]	1/2	50	1/2"-14 NPT	325



AIRHOSE35

Air Hoses, Reinforced Polyurethane

Stock No.	Hose I.D., inches	Hose Length, feet	Thread Size	Temperature Range	Working Pressure, PSI
AIRHOSE35 [‡]	3/8	35	1/4" NPT	-40-165 °F (-40-73.9 °C)	200 @ 70 °F (21 °C)
AIRHOSE50 [‡]	3/8	50	1/4" NPT	-40-165 °F (-40-73.9 °C)	200 @ 70 °F (21 °C)
AIRHOSE100 [‡]	3/8	100	1/4" NPT	-40-165 °F (-40-73.9 °C)	200 @ 70 °F (21 °C)
AIRHOSE1250	1/2	50	1"-11-1/2" NPT	-40-165 °F (-40-73.9 °C)	200 @ 70 °F (21 °C)

- Extremely lightweight for easy maneuverability
- Reinforced construction eliminates layer separation resulting from expansion and contraction during pulsating operations
- Resists abrasions better than PVC and rubber hoses
- Easy to wrap and store even in subzero weather
- UV stabilized for longer outdoor life
- Strain relief features a tight bending radius to virtually eliminate hose kinking
- Reusable fittings and strain reliefs for longer life

AIRHOSEKIT Replacement End for 3/8" Air Hose

AIRHOSESPLCR Splicer Kit for 3/8" Air Hose



YA502M

Air Swivel Connectors

Stock No.	Thread Size	Maximum Pressure, PSI	Airflow
ASC14	1/4" NPT	150	Up to 35 SCFM (991 LPM)
ASC14U	1/4" NPT	150	Up to 35 SCFM (991 LPM)
YA502M	1/4" NPT	150	Up to 4.6 CFM (33 SCFM)
YA503M	3/8"- 18 NPT	150	Up to 6.3 CFM (45 SCFM) [178 LPM]

- Swivels turn 360° at two points for complete tool maneuverability
- Air hoses hang straight to the floor

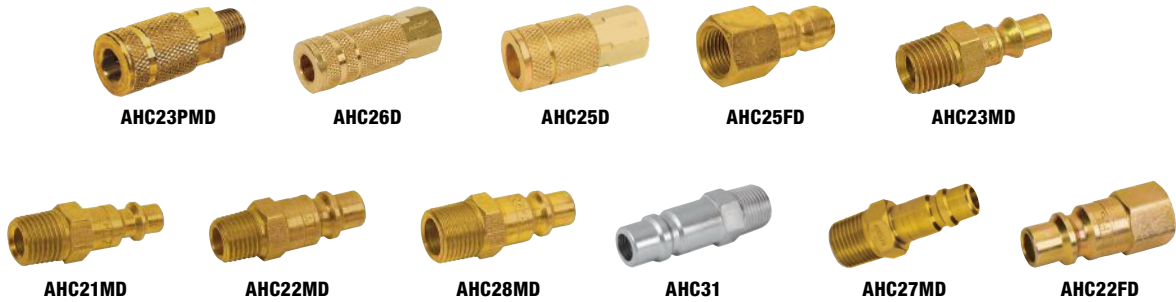

Air Line Quick Couplers

Body Size, inches	Style	Thread Size	Quick Coupler Male	Quick Coupler Female	Adapter Male	Adapter Female
1/4	Lincoln®	1/4"-18 NPT	—	AHC26D‡	AHC26MD‡	AHC26FD‡
1/4	Tru-Flate®	1/4"-18 NPT	—	AHC24D	AHC24MD‡	AHC24FD‡
3/8	True-Flate®	1/4"-18 NPT	—	AHC25D‡	AHC25MD‡	AHC25FD‡
1/4	ARO®	1/4"-18 NPT	AHC23PMD‡	AHC23D‡	AHC23MD‡	AHC23FD‡
1/4	Industrial Interchange	1/4"-18 NPT	AHC21PMD‡*	AHC21D‡	AHC21MD‡	AHC21FD‡
3/8	Industrial Interchange	1/4"-18 NPT	—	AHC22E‡*	AHC22MD‡	AHC22FD‡
3/8	Industrial Interchange	3/8"-18 NPT	—	AHC28D‡*	AHC28MD‡	AHC28FD‡
1/2	Industrial Interchange	3/8"-18 NPT	—	—	AHC31‡	—
1/2	Industrial Interchange	1/2"-14 NPT	—	AHC27D‡**	AHC27MD‡	AHC27FD‡
1/4	Rigid Mounting	1/4"-18 NPT	—	AHC21PD‡*	—	—
1/4	Hi-Flow	1/4"-18 NPT	—	AHCC98C‡	AHCCP97C‡	—
1/4	Hi-Flow HVLP	1/4"-18 NPT	AHCC91C‡	AHCC90C‡	—	AHCCP90C

*Conforms to Mil Spec. MIL-C-4109E.

**Rigid Mounting: brass "push-to-connect" type; use in place of AHC21 and AHC22 on rigid piping systems only.

All adaptors are plated steel to improve durability

Air Valves and Manifolds

AHC300 Multiline Air Manifold (Blue-Point®)

- Capacity of three air lines running at the same time
- Allows three workstations to use the same air supply
- Evenly distributes air through three different lines

IM10D Air Valve (Blue-Point®)

- Volume of airflow can be regulated with 1/4 turn of the control knob
- Male/female thread sizes

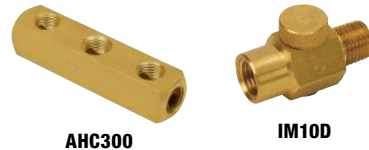

AHC300

IM10D



- Do not use wire brushes above their maximum rated RPM.
- ‡These products can expose you to chemicals which are known to the state of California to cause cancer and reproductive harm. See pages P1–P2 for details.
- Read Safety Precautions on pages W1–W4

GENERAL ACCESSORIES



ATHUBSCRUBKIT



ATHUBSCRUBSMPADS



ATHUBSCRUB



CL6



IM1PTMP6



IM10ZMP12



IM1PT

Abrasive Discs (Blue-Point®)

ATHUBSCRUBKIT† Hub Scrub Kit (Blue-Point®)

- Quickly and effectively removes rust and debris from hub surfaces
- 1/2" drive allows for use with an impact gun—simply attach like any standard impact socket
- High-quality tool sculpted from aircraft-grade aluminum
- The majority of hub cleaning tool products on the market require use with an air or cordless drill
- Enhances shop productivity by not having to change from an impact to a drill and back to an impact
- Improves wheel assembly with better torquing against a clean surface and improving balance by removing rust, dirt and other foreign materials from the lug threads, hub surface
- Includes ATHUBSCRUB, ATHUBSCRUBLG, ATHBSRBPADS (1 pk/3 pc), ATHUBSCRUBSMPADS (1 pk/3 pc), ATHUBSCRUBLGPADS (1 pk/3 pc) in a storage tray

ATHUBSCRUBLG‡ Large Truck Hub Scrubber (Blue-Point®)

ATHUBSCRUBLGPADS‡ Replacement Truck Pads, 4 pk (Blue-Point®)

- Fits 22 mm stud size on large trucks

ATHUBSCRUBSMPADS‡ Replacement Compact Vehicle Pads, 4 pk (Blue-Point®)

- Fits 15 mm stud size on smaller vehicles

ATHUBSCRUB Hub Scrubber with Pad (Blue-Point®)

- Invaluable tool for all wheel service applications
- Quickly removes rust and corrosion from studs, rotors, hubs and wheels
- Used with any 1/2" drive impact wrench
- Long-lasting, replaceable abrasive pads

ATHBSRBPADS Abrasive Pad, 4 pk (Blue-Point®)

- Four pack of replaceable abrasive pads

Lubrication Accessories

CL6 Cutting Oil

- Superior anti-weld and lubricating properties reduce heat buildup in drill bits, grinding burrs and other metal cutting tools
- 1 pt bottle

IM1PTMP6 16 oz Air Motor Oil (6 pk)

- Cleans all piston and rotary air motors, and helps prevent rust formation
- (6 pk) of IM1PT 16 oz bottles

IM10ZMP12 1 oz Air Motor Oil (12 pk)

- (12 pk) of 1 oz bottles

IM1PT 16 oz Air Motor Oil

- Improves performance and extends the life of power tools with regular use of Snap-on® motor oil
- Specially formulated to lubricate, clean and protect expensive components
- Used daily on all piston and rotary air motors
- 16 oz bottle

Tote Bags

CTTOTE Power Tool Tote Bag

- Wide opening for easy access to tools—extra padding for protection
- Durable 600 Denier exterior for strength
- Interior pockets and compartments for tool organization
- Padded handles for comfortable transport
- Reinforced bottom for strength
- Six external pockets for extra storage
- Approximate inside dimensions, open: 18" L x 8" W x 11-1/2" D (457 x 203 x 292 mm)

BPTOTE Tote Bag (Blue-Point®)

- Heavy-duty 600 x 300 D-polyester
- Water-resistant, rugged and versatile
- Wide top opening for easy access
- Multiple interior and external pockets for organization
- Overall dimensions: 16-1/2" L x 10-1/2" W x 12-1/4" H



CTTOTE



BPTOTE