

# SERIOUS TOOLS FOR CRITICAL IND

TOOL CONTROL & STORAGE



AVIATION TOOLS



TORQUE & TENSIONING



TOOLS@



# INDUSTRIES

*INNOVATING SINCE 1920*

HEIGHT



**HAND &  
SPECIALTY TOOLS**

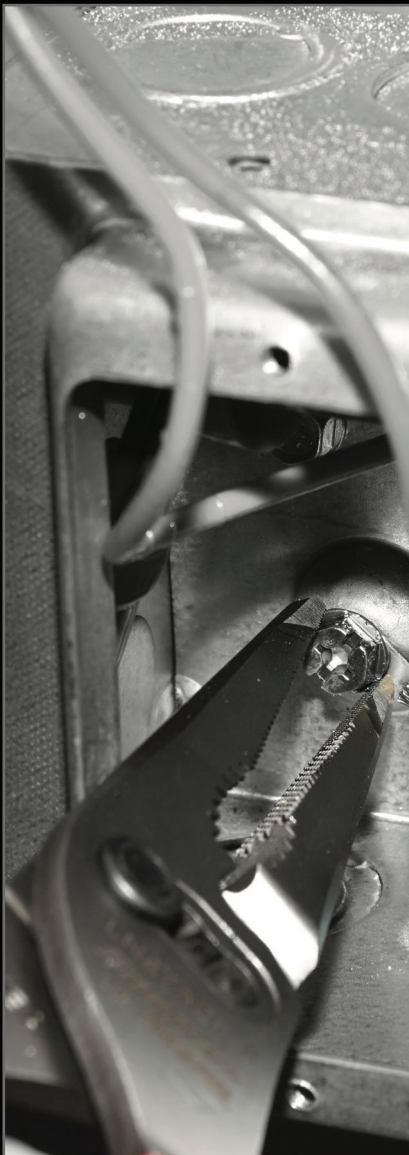

**POWER  
TOOLS**



**FLEET  
MAINTENANCE**

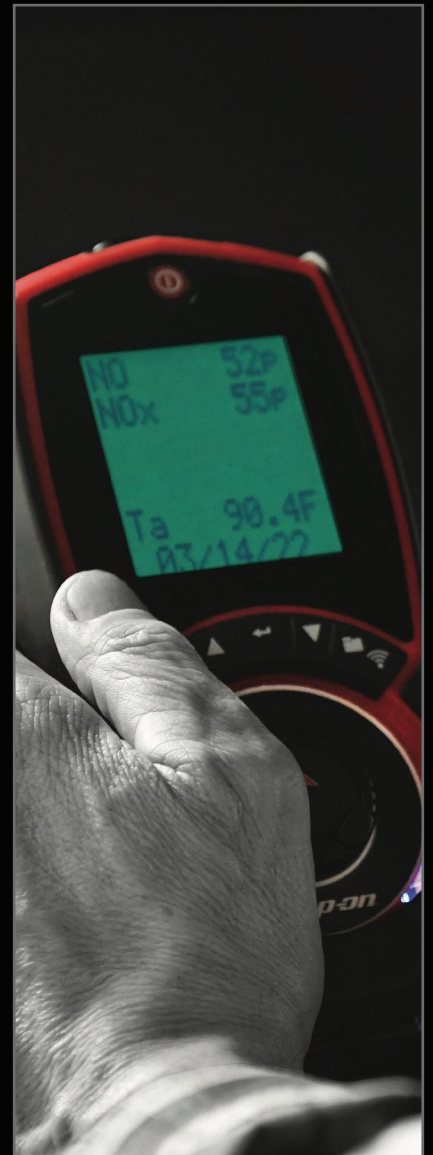

**QUICK REFERENCE**

# OUR FIVE-STAR APPROACH TO TOOL KITTING

---

## ORGANIZATION

Tons of options for organizing tools: bags, shadow boards, tool silhouette decals, foam inserts for portable cases, custom foam layouts for tool box drawers, and more. When you're highly organized, you're highly productive.

## TOOL MANAGEMENT

Management follows organization. Whether you require simple visual management, or a program to meet FOD and FME requirements, we can tailor a management program for virtually any need with our Level 5 Tool Control System offering.

## SOURCING AND INTEGRATION

Need a tool that requires additional sourcing beyond our standard offerings? No problem. We can do the sourcing for you, and integrate the components into your kit.

## TOOL IDENTIFICATION

At Snap-on®, we have in-house laser tool engraving capabilities to match your identification system – whether you're looking for etching on a specific kit, or serially marked tools.

## ON-SITE TOOL MANAGEMENT

Sometimes you need someone to actually go on-site, check inventories, manage updates, and handle replacements. Snap-on® is ready to assist you with all your tool needs.



## LOOKING FOR TOOL KITTING?

Contact your Account Manager  
or call 1.877.740.1900 for details.

# TOOL CONTROL



# TOOL CONTROL THAT PUTS YOU IN COMMAND

For technicians, lost tools can kill a productive workday with wasted time. That's why Snap-on has kept technicians organized and productive since 1920. Now, over 100 years later, Snap-on offers the most advanced form of tool control in the industry: Level 5 Tool Control System. From seamlessly integrated access control to fully automated systems that automatically monitor who has which tools and where they're working, the Level 5 Tool Control System improves every aspect of tool management. And it works with your crew, at the speed of work, to decrease downtime and improve productivity. That way everyone can concentrate on what matters most—the job at hand.

## LEVEL 5 TOOL CONTROL SYSTEM IS TILTING THE PLAYING FIELD.



### ORGANIZATION

The more organized you are, the easier it is to get the job done right. Starting with a complete tool audit conducted by a Snap-on® Solutioneer, we'll help you determine the level of tool control you need and design a specialized tool set with your specific applications in mind.



### VISIBILITY

Finding the right tool for the job can take time—even more so if they're hard to see. Our visibility solutions decrease the time to know the tool is missing and find tools you need. Our selection of high-visibility tool handles, custom color foam inserts, toolbox organizers, and pegboards don't just raise the visibility of your tools, they raise the productivity of your team.



### ACCESS CONTROL

Don't get locked in to using keys that can be lost or shared. Our tool storage units have Keyless Access Control, which means your teams have access to just the tools they need. You can configure the tool control to work with HID proximity badges or PINs. And with our proprietary software, you can control access from one system, or from your network. With our Access Control, you can keep productivity up while keeping unauthorized users out.



### ASSET MANAGEMENT

What if you could keep track of your key assets all from one place? With Level 5 software system, you can. It provides full reports on everything you want to keep tabs on. It will even update you when a tool needs to be restocked or ordered. Our solution is designed to preserve your assets and your sanity.



### AUTOMATION

When you minimize human error, you minimize FOD and FME, and maximize productivity. Our Automated Tool Control handles all tool control and tracking automatically. Whether it's by digitally scanning every drawer or by using RFID tags to track large equipment, our systems notice which tools have been removed or added, and track each tool by part number and user. Keep an eye on your productivity, without getting in the way of finishing the job.



**SPECIALIZED TOOL SETS**



ORGANIZATION



**KMC18GMTKG**

**General Maintenance Technician's Kit**

- Mobile so that tools may be easily deployed to any jobsite; rain or shine
- Black over red tool control foam ensures an easy way to check for the presence or absence of tools
- Contains over 200 individual tools and All-Weather Mobile Tool Chest
- 22.1" wheel base on the wide corners for stability
- Innovative latch system for secure lid closure
- Telescoping trolley handle with higher reach
- Over-top hinged lid can be used as a seat when the case is open
- Drawers fully extend on Snap-on's proprietary composite slides

**Kit Includes:** 102 Drive Tools and Sockets, 8 Screwdrivers, 70 Wrenches, 7 Pliers, 37 Miscellaneous Tools, 1 Multimeter, Foam **IKCFM0000047**, Case **KMC18062PBK** (black) or **KMC18062PGR** (green)

Stock No.	Description
KMC18GMTK	Black
KMC18GMTKG	Green



**KMOC23GMTK**

**General Maintenance Tool Kits**

**KMOC23GMTK (General Maintenance Tool Kit)**  
**KMOC23GMTKBA (Berry Amendment Compliant General Maintenance Tool Kit)**

- Outside dimensions are 24" wide x 15 deep x 18" high, in the closed position
- Fully extendable drawers with positive stops to prevent inadvertent removal
- All terrain wheels allow for use on grass, gravel, or paved surfaces
- Pressure relief valve regulates airflow during altitude changes
- Stackable design – even when fully loaded
- Snap-in Padlock Holder
- Meets or exceeds applicable military standards
- Telescoping trolley handle with 43" reach

**Maximum Mobility Tool Set**

**9060VMTB**

- Designed specifically for the mechanic on the go
- Rapid tool access and accountability helps protect valuable vehicles and equipment
- Snap-on® tool control foam system measurably increases productivity
- Tools are furnished in custom foam and loaded into removable drawers
- Rugged trolley handle and wheels for easy and secure mobility
- Seven removable drawers plus foam tray in top of case
- Two automatic pressure equalization valves
- Water, temperature, drop, and impact resistant design and construction

**Kit Includes:** 105 Drive Tools and Ratchets, 10 Screwdrivers, 60 Wrenches, 7 Pliers, 33 Miscellaneous Tools, Foam and Pelican 0450 Case



**9060VMTB**



**ORGANIZATION**

**SPECIALIZED TOOL SETS**

**General Mechanic's Tool Kits**

**General Mechanic's Tool Kits**

**Kit Includes:** 55 Sockets, 26 Wrenches, 6 Pliers, 5 Screwdrivers and 50 Miscellaneous/Specialty Tools Available in choice of Metal Tool Chest or Soft Sided Bag.

**Tool Set In Metal Tool Chest**

**GMTKBOXWT**

- 26", Nine drawer top chest
- Lock'n Roll® System prevents drawers from driving open during movement
- Rolled drawer edges for strength and safety
- High security tubular interchangeable locks



**GMTKBOXWT**

**Tool Set In Soft Sided Bag**

**GMTKTLBAGWT**

- Easy to carry and stow
- Zips open at top or end to allow individual tool pallets to be removed
- No sharp edges
- Rugged, heavy-duty materials made from 100% polyester-coated Cordura
- Contains five individual tools pallets inside see-through, zippered, protective vinyl pouches for security and convenience
- Two clear vinyl I.D. pockets on the outer surface - top and end
- Additional I.D. pockets-to contain tool inventory lists, pallet bills of material, DA form 2404, etc.
- Zippers align-for easy padlocking



Soft-sided bag available "Flightline Black"



**GMTKTLBAGWT**

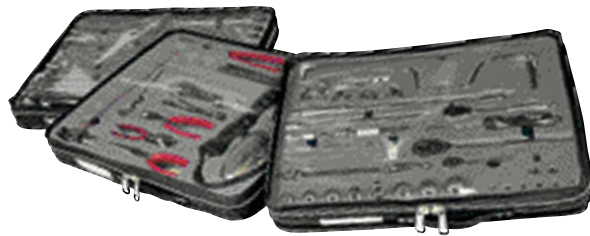

**Pallets from Soft-sided Bag**

Stock No.	Description	Box/Bag Size (W x H x D)	Loaded with Tools* - Weight, lb (kg)	Pallet Size (W x H)	Standard Color
GMTKBOXWT	General Mechanic's Tool Kit w/ tools & Foam in a 9 drawer KRA4059A Snap-on® Metal Chest	26" x 17-3/16" x 14-23/32"	107 (48.5)	Top Compartment Dimensions - 25-13/16"W x 13-3/4"D x 3-7/8"H	Snap-on® Red
GMTKTLBAGWT	5 Pallet, General Mechanic's Tool Kit w/tools - Flightline Black	24" x 18" x 11"	67 (30.3)	20 x 16"	Flightline Black

\* Tool weight may vary. Snap-on® reserves the right to change tool content.

**Standard Flightline Bags**

Stock No.	Description
R5184BK	Single Sleeve
FLF8000	4 Pallet FOD Bag - Top Load, No Pallet or Foam
FLF8200	4 Pallet FOD Bag - Clamshell Open, No Pallet or Foam
FLF8400	2 Pallet FOD Bag - Clamshell Open, No Pallet or Foam
FLF8800	5 Pallet FOD Bag, No Pallet or Foam
FOMFLPLT	Standard Foam Pallet Bag

Set cabinetry and components are subject to change and may not be exactly as illustrated.



- Must wear eye protection
- Read safety precautions on pages W1 to W4

# TOOL SETS & CUSTOM KITTING



ORGANIZATION

## Snap-on® Foam Tool Control Systems

Tool Control from Snap-on® Industrial is the most sophisticated and comprehensive Tool Control System in the world. From stationary installations to portable tool boxes in road service vehicles, Snap-on® offers solutions for every application. Our optional foam Tool Control System allows the USPS tool set to be custom fit into the tool boxes. Includes foam panels, with a form-fit cut-out for each tool in the set.



KRA4107FPB0

Contents subject to change. Consult your Account Manager for up-to-date set contents.

## USPS Tool Sets from Snap-on® Industrial

Snap-on® Industrial offers USPS Vehicle Maintenance Facilities the finest tool sets available in the industry. Featuring Snap-on® and Williams® branded products, these sets provide USPS repair facilities unprecedented quality, versatility, warranty, and service options. The optional foam tool inventory control system makes keeping track of tools easy and convenient, reducing tool loss, and increasing productivity.

**Developed exclusively for the needs of USPS vehicle repair facilities, this set represents the full Certified USPS Maintenance Tool Set.**

**Kit Includes:** Sockets, Wrenches, Screwdrivers, Hammers, Chisels, Pliers, C-clamps, Scrapers, Locking Pliers, Snap-ring Pliers, Hex Keys, Specialty Tools, and more!

Available in four components to suit each facility's unique needs:

Stock No.	Description
KRA4107FPB0	7 Drawer Roll Cabinet
KRA4114FPB0	4 Drawer Top Chest
USPSTCF-1	Tool Control Foam Kit
USPSTS-1	244 Piece Tool Set Only

### This Set Contains a Full Assortment Of:

- Sockets
- Wrenches
- Screwdrivers
- Hammers
- Chisels
- Pliers
- Tool Storage Chests and Cabinets
- C-Clamps
- Scrapers
- Locking Pliers
- Snap-ring Pliers
- Hex Keys
- Specialty Tools
- and more...

## CREATE CUSTOM TOOL CONTROL TO INCLUDE THE TOOLS YOU ALREADY OWN.



Snap-on can evaluate your current tools and storage unit on site with our True-Fit software and create custom foam layouts just for your application.

No taking tools offline for days for physical scanning.

No shipping tools off premise for silhouette development.

No back-and-forth.

Contact your Account Manager to get started today!

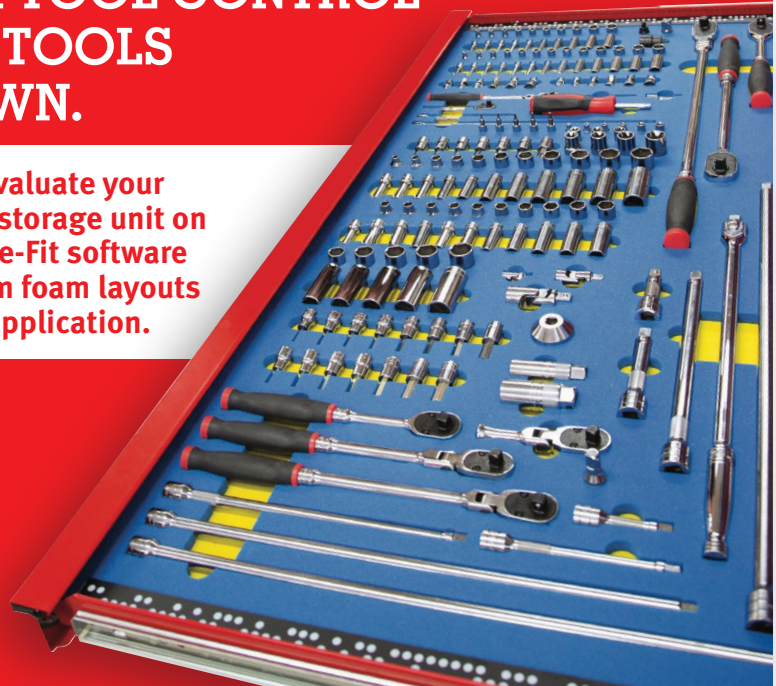



**ORGANIZATION**

**SPECIALIZED TOOL SETS**

**TOOL CONTROL**

**Master Maintenance Service Kit - Tools Only  
4338GS**

Own a variety of essential hand and power tools necessary to perform most maintenance operations safely and efficiently.

**Kit Includes:** All the tools in the General and Intermediate Kits plus larger pinch bars, hammers, adjustable spanner wrenches, c-clamps, 3/4" drive 12-point shallow sockets to 2-3/8", 3/4" drive extensions and ratchet, 1/2" drive shallow and deep impact sockets, 1" combination wrenches to 1-1/2", extended locking pliers, snap-ring pliers and 1/2" drive turbo sockets to 1".



4338GS

**Metric Set Building**

Nothing else gets the job done as safely and efficiently as having the right tools and having them when needed. To assist you in bringing this about, our many years of close association with the industry have been consolidated into these expertly compiled add-on sets.

**4102GM1 4000 Series Metric - Tools Only  
Build on your existing metric set to achieve a complete inventory of metric tools!**

**Set Includes:** Metric nut drivers, L-type hex wrenches, 1/4" drive 12-point deep and shallow sockets to 14mm, 3/8" drive 12-point deep and shallow sockets to 19mm, 12-point combinations wrenches to 22mm, four-way angle head wrenches, double end flare nut wrenches, box wrenches, and socket drivers.



4102GM1

**General Maintenance Service Kit - Tools Only  
4161GS**

**Kit Includes:** 3/8" drive hex drivers, universals to 3/4", combination wrenches to 1", expanded punch sizes, 1/2" drive ratchet, extensions, breaker bar, 1/2" drive shallow 12-point sockets to 1-5/16", open end wrenches to 1-5/16", box wrenches to 9/16", 1/4" drive 12-point deep sockets to 9/16", nut drivers and expanded pliers



4023SGACC

**4000 Series Maintenance Add-On Set  
4023GSACC**

- Set Includes: Tap and dies, rethreading tap and dies, extractors, pipe wrenches, strap wrenches, awls, nut splitter, ruler, mirror, and pick-up tools
- Set also has expanded files, snap-ring pliers, scrapers, pry bars, saws, and hammers
- Roll cab is not included
- Set contents are subject to change and may not be exactly as illustrated and listed



Contact your Account Manager to choose your Roll Cab and to add a custom foam insert.

Set cabinetry and components are subject to change and may not be exactly as illustrated.



- Must wear eye protection
- Read safety precautions on pages W1 to W4

**SPECIALIZED TOOL SETS**



ORGANIZATION

**3/4" Drive Impact Sockets & Cordless Impact Wrench Set**

**425IMCT**

- (17) pc. socket set features Snap-on Flank Drive® technology providing superior gripping power while guarding against rounding of fasteners
- Includes (1) 3/4" drive universal joint, (1) 3/4" drive 3" extension, (1) 3/4" 7" extension, (1) 3/4" 10" extension
- Includes 18V 3/4" Drive MonsterLithium Cordless Impact Wrench Set
- Portable, weather resistant case features a collapsible handle and rugged wheels
- Two-toned (red & black) Tool control foam holds tools securely
- 25 pieces



425IMCT



WPGENERAL-1

**General Service Set**

**WPGENERAL-1**

- Ideal selection of high-quality tools for general service in and around the wind farm
- 106 pc tool set comes in a rugged, waterproof, and virtually unbreakable hard case, packed in tool-control foam

**Set Includes:** 1/4" drive SAE shallow and deep sockets and drive tools, 3/8" drive SAE deep and shallow sockets and drive tools, 5pc screwdriver set, ratcheting box wrenches (midget and combination), five pair of pliers, hammers, punches, hacksaw and more



WPGENERAL-1



434HDC

**35 pc. 3/4" Drive 12-Point SAE General Service Set**

**434HDC**

- Flank Drive® wrenching system provides superior gripping power
- Precision-crafted from special alloy steel for strength and durability
- Nickel-chrome finish is easy to clean and helps protect against corrosion
- Portable, weather-resistant case features a retractable handle and rugged wheels
- Durable foam insert holds tools securely
- Applications include Oil & Gas Industries, Heavy-Duty Fleet, General Industry and Military

Set cabinetry and components are subject to change and may not be exactly as illustrated.



**ORGANIZATION**

**SPECIALIZED TOOL SETS**

**Industrial Essentials Tool Sets**

**ITKCARTBLACK - Tool set with Black cart**

**ITKCARTBLUE - Tool set with Blue cart**

**ITKCARTRED - Tool set with Red cart**

- Built to accommodate this tool set is the 36" Heavy Duty Shop Cart (KRSC242) that rolls smoothly and easily wherever you go
- Includes a power strip with (5) AC and (2) USB ports for secure charging in top compartment
- Includes SpeedDrawer for small parts organization. Top compartment provides openings to store long pry bars vertically
- Keeping track of tool inventory is essential and Snap-on tool control foam is a must
- This set comes pre-assembled with pre-cut foam for maximum organization, tool identification, inventory and storage
- Set cabinetry and contents are subject to change and may not be exactly as illustrated and listed



**ITKCARTBLACK**



- Must wear eye protection
- Read safety precautions on pages W1 to W4



**Industrial MRO Pro Tool Set**

Comes complete with KRL7022C roll cab (available in three colors).  
Includes standard SAE product only

**Tool set with foam conveniently pre-assembled inside roll cab**

- *ITKPLUSRAYB (Red Roll Cab)*
- *ITKPLUSBAYB (Black Roll Cab)*
- *ITKPLUSBLAYB (Blue Roll Cab)*

Set cabinetry and components are subject to change and may not be exactly as illustrated.



ORGANIZATION

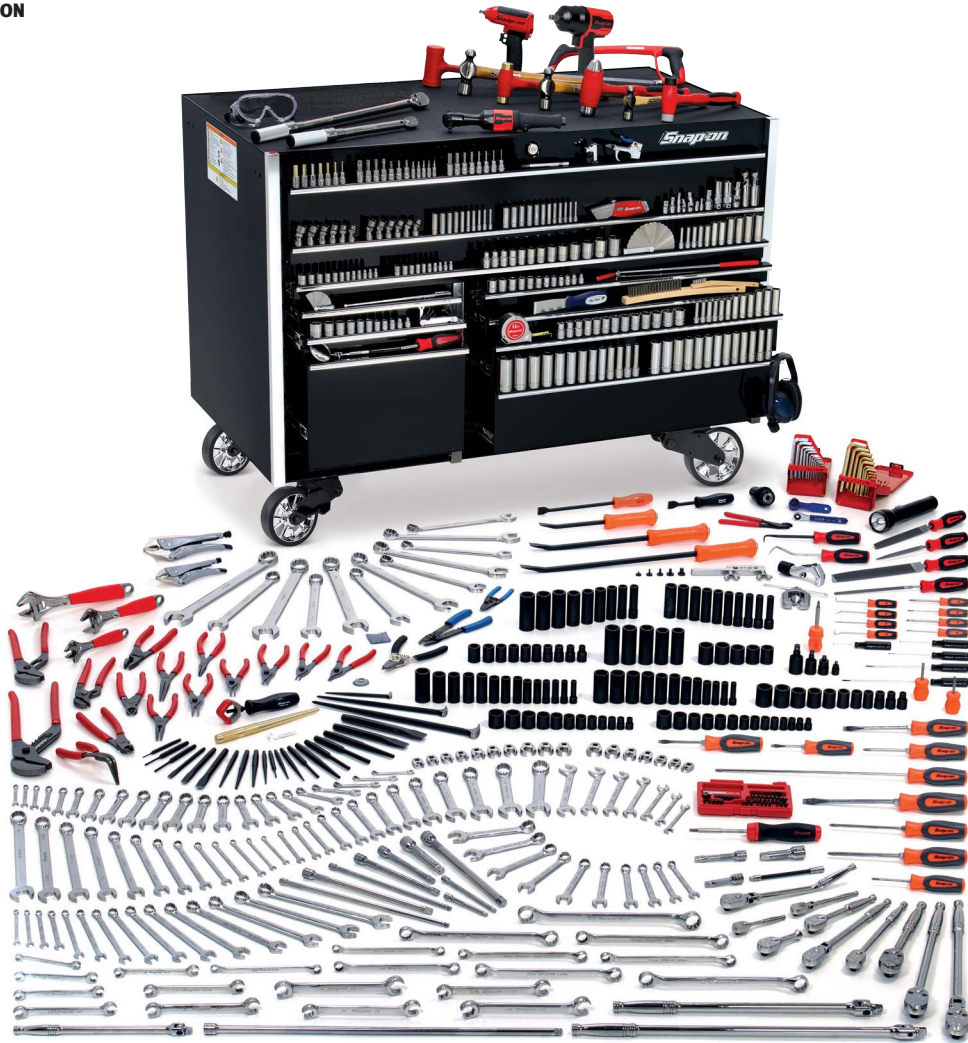

### Fleet Pro Tool Set

Comes complete with KRL7022C roll cab (available in three colors).  
Includes standard SAE and Metric product.

#### Tool set with foam conveniently pre-assembled inside roll cab

- FMTKPLUSRAYBM (Red Roll Cab)
- FMTKPLUSBAYBM (Black Roll Cab)
- FMTKPLUSBLAYBM (Blue Roll Cab)



• Must wear eye protection  
• Read safety precautions on pages W1 to W4



**Fleet Pro Master Tool Set**

Tool Set comes complete with KRL1023C roll cab (available in three colors).  
Includes standard SAE and Metric product.

**Tool set with foam conveniently pre-assembled inside roll cab**

- *FMTKHUGERAYBM (Red Roll Cab)*
- *FMTKHUGEBAYBM (Black Roll Cab)*
- *FMTKHUGEBLAYBM (Blue Roll Cab)*

Set cabinetry and components are subject to change and may not be exactly as illustrated.



## ORGANIZATION

# SET BUILDING

## U.S. Sets

### An Unequaled Opportunity

When we introduced our set building program it revolutionized the industry, for the first time there was a planned way to expand tool sets as work and responsibilities evolved and grew. It is designed to provide the most used tools in the most likely progression. As metric tools became the standard in the industry, we began offering a greatly expanded metric selection with a master set that tops anything else available.

Ask your Snap-on® Industrial Account Manager for more information on how you can build exactly the right tool set for your specific needs.

### How the Program Works

If you're building a set from the ground up, start with our **9100GSBO** Apprentice Set. It includes a balanced selection of 1/4", 3/8" and 1/2" square drive tools, wrenches, screwdrivers, pliers, punches and chisels — a basic set for routine maintenance. We've also put increased emphasis on getting you all the metric tools you need, as they are increasingly becoming the standard in many industries.

When your needs grow, the second tool group provides more than 100 additional standard and specialty tools for more advanced work. Each new tool group offers recommendations on the appropriate storage chests and cabinets to help you stay organized and productive. Through this method of steady, planned expansion, you can continue building your tool set until you've achieved the ultimate selection of matched hand tools and storage units.

### U.S. Apprentice Set

#### 9100GSBO Complete Apprentice Set

- Includes **9100GSO** and the **KRA2055FPBO** Top Chest

#### 9100GSO Apprentice Set

- More than 100 pieces for a well-balanced selection; tools only
- Does not include a top chest

#### 9100GSM Metric Plus Apprentice Set

- **9100GS** Set plus, **AWM110DK** Metric Hex Wrench Set (11 pc), **212FMY** Metric 12-Point Socket Set (12 pc) and **OEXM710B** metric 12-Point Combination Wrench Set (10 pc)
- Does not include a top chest



9100GSO

### U.S. Set 2

#### 9200GSB Complete U.S. Set 2

- Includes **9100GSO**, **9000GS2**, plus the **KRA4059FPBO** top chest

#### 9200AGSO U.S. Set 2

- Includes **9100GSO** and **9000GS2**
- Tools only; does not include tool storage

#### 9000GS2 Add-On Group 2

- More than 100 pieces
- Does not include a tool storage unit

Warning: In the set illustrations on this page and following pages, storage unit drawers are shown open for display purposes only. In use, storage unit could tip and cause injury or damage if a number of loaded drawers are extended.

U.S. and metric set cabinetry and contents are subject to change and may not be exactly as illustrated.



9200GSB

# TOOL CONTROL



- Must wear eye protection
- Read safety precautions on pages W1 to W4



U.S. Sets



9300GSBO

U.S. Set 3

**9300GSBO Complete U.S. Set 3**

- Includes 9200AGS and 9200GS30, plus the KRA4008FPBO Roll Cab and KRA4059FPBO Top Chest

**9000GS30 Add-On Group 3**

- More than 100 pieces in the add-on to 9200AGSO U.S. set
- Tools only; does not include tool storage

**9300GSO U.S. Set 3**

- Includes 9200AGS and 9000GS3
- Tools only; does not include tool storage

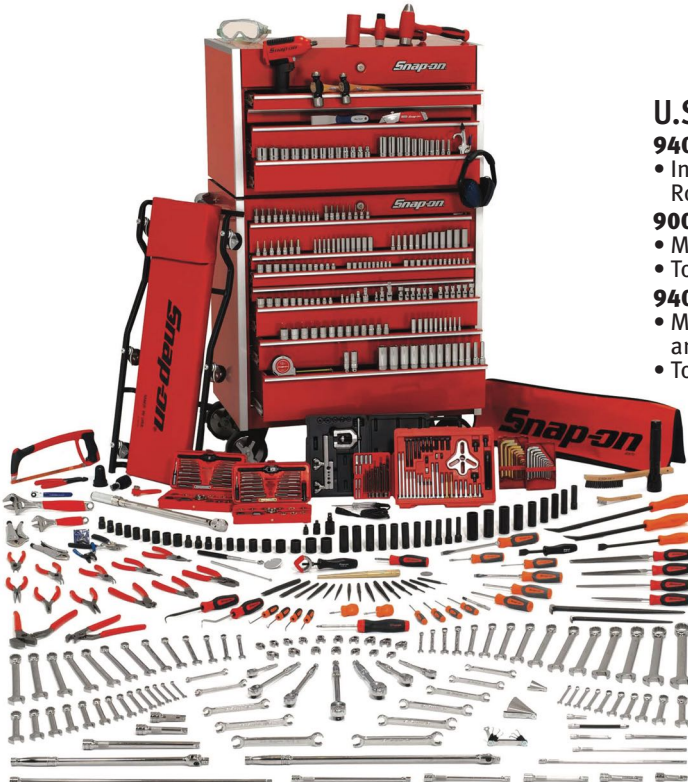

9400GSBO

U.S. Set 4

**9400GSBO Complete U.S. Set 4**

- Includes 9300GSO, 9000GS40 plus KRL756CPBO Roll Cab and KRL751FPBO Top Chest

**9000GS40 Add-on Group 4**

- More than 250 pieces in the add-on to 9300GSO
- Tools only; does not include tool storage

**9400GSO U.S. Set 4**

- More than 600 pieces, includes 9300GSO and 9000GS40
- Tools only; does not include tool storage

Set cabinetry and components are subject to change and may not be exactly as illustrated.



ORGANIZATION

SET BUILDING

U.S. Sets

TOOL CONTROL

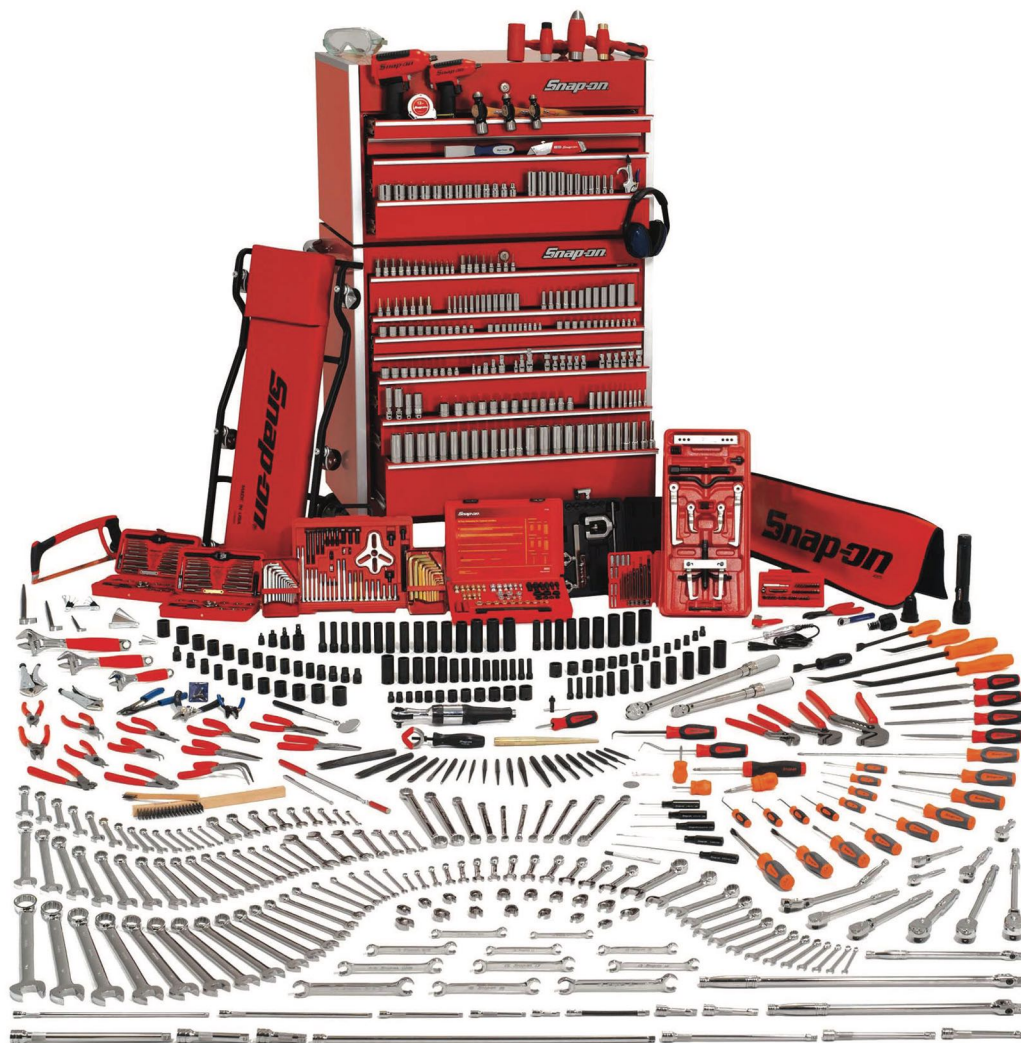

9500GSBO

### U.S. Set 5

#### 9500GSBO Complete U.S. Set 5

- Includes 9400GSO and 9000GS50, plus the KRL756CPBO Roll Cab and KRL751PBO Top Chest

#### 9500GSO U.S. Set 5

- More than 800 pieces, includes 9400GSO and 9000GS50
- Does not include tool storage

#### 9000GS50 Add-On Group 5

- More than 150 pieces in the add-on to 9400GSO
- Tools only; does not include tool storage

Warning: In the set illustrations on this page and following pages, storage unit drawers are shown open for display purpose only. In use, storage unit could tip and cause injury or damage if a number of loaded drawers are extended

U.S. and metric set cabinetry and contents are subject to change and may not be exactly as illustrated.

- Do not open more than one loaded drawer at a time
- Keep children away
- Close lid, lock drawers and doors before moving
- Apply brakes on locking casters when not moving the unit
- Do not step in or on drawers
- Secure units together with fasteners
- Do not pull; push to move
- Wear gloves when lifting by edges
- Keep feet and fingers clear of edges when stacking, hanging, or moving units
- Read additional safety precautions on pages W1 to W4



- Must wear eye protection
- Read safety precautions on pages W1 to W4



U.S. Sets



9600GSBO

U.S. Set 6

**9600GSBO Complete U.S. Set 6**

- Includes 9500GSO and 900GS60, plus KRL791PBO Tool Chest, KRL722PBO Roll Cab and KRA276A Wall Cabinet

**9600GSO U.S. Set 6**

- More than 1,000 pieces, includes 9500GSO and 900GS60
- Tools only; does not include tool storage

**9000GS60 Add-On Group 6**

- More than 250 pieces in the add-on to 9500GSO
- Tools only; does not include tool storage

Set cabinetry and components are subject to change and may not be exactly as illustrated.



ORGANIZATION

## SET BUILDING

### Metric Sets

TOOL CONTROL



9100GMBO

### Metric Set A

#### 9100GMBO Complete Metric Set A

- More than 150 pieces
- Includes 9100AGMO, plus KRA4059FPBO Top Chest

#### 9100AGMO Metric Basic Set A

- Tools only; does not include tool storage
- Includes a basic selection of ratchets, sockets, wrenches, screwdrivers, pliers, and accessories



9100AGMO



9200GMBO

### Metric Set B

#### 9200GMBO Complete Metric Set B

- Includes 9100AGMO and 9000GM20, plus KRA4059FPBO Top Chest, and KRA4008FPBO Roll Cab

#### 9200GMO Metric Set B

- More than 400 pieces includes all tools in 9100AGMO and 9000GM20 add-on set
- Tools only; does not include tool storage

#### 9000GM20 Add-On Group B

- More than 200 pieces
- Tools only; does not include tool storage



9000GM20



- Must wear eye protection
- Read safety precautions on pages W1 to W2



Metric Sets

Metric Set C

**9300GMBO Complete Metric Set C**

- Includes 9200GMO and 9000GM30, plus KRL751PBO Top Chest, and KRL756APBO Roll Cab

**9300GMO Metric Set C**

- More than 600 pieces
- Includes all tools in 9200GMO and 9000GM30
- Does not include tool storage

**9000GM30 Add-On Group C**

- More than 200 pieces
- Tools only; does not include tool storage



9300GMBO

Metric Set D

**9400GMBO Complete Metric Set D**

- Includes 9300GMO and 9000GM40, plus KRL751PBO Top Chest, KRL756CPBO Roll Cab, and KRA276D Wall Cabinet

**9400GMO Metric Set D**

- More than 800 pieces
- Includes all tools in 9300GMO and 9000GM40
- Does not include tool storage

**9000GM40 Add-On Group D**

- More than 175 pieces
- Tools only; does not include tool storage



9400GMBO



ORGANIZATION

# TOOL CONTROL SET BUILDING

TOOL CONTROL

## U.S. Tool Control Sets

Please refer to [b2b.snapon.com](http://b2b.snapon.com) for the full set listing

### Apprentice Set

Includes more than 100 pieces with complete Tool Control Foam System.

Stock No.	Description
KRA2055FPBO	Snap-on® Top Chest
9100GSO	9100 - Tools Only
VF9100GSB-UY	9100 - Foam Only (Blue over Yellow)

### Complete Set 2

Includes more than 200 pieces with complete Tool Control Foam System.

Stock No.	Description
9200AGSO	9200 - Tools Only
KRA4059FPBO	Snap-on® Top Chest
VF9200GSB-UY	9200 - Foam Only (Blue over Yellow)

### Complete Set 3

Includes more than 300 pieces with complete Tool Control Foam System.

Stock No.	Description
9300GSO	9300 - Tools Only
KRA4008FPBO	Snap-on® Roll Cab
KRA4059FPBO	Snap-on® Top Chest
VF9300GSB-UY	9300 - Foam Only (Blue over Yellow)

### Complete Set 4

Includes more than 600 pieces with complete Tool Control Foam System.

Stock No.	Description
9400GSO	9400 - Tools Only
KRL751PBO	Snap-on® Top Chest
KRL756CPBO	Snap-on® Roll Cab
VF9400GSB-UY	9400 - Foam Only (Blue over Yellow)

### Complete Set 5

Includes more than 800 pieces, with complete Tool Control Foam System.

Stock No.	Description
9500GSO	9500 - Tools Only
KRL751PBO	Snap-on® Top Chest
KRL756CPBO	Snap-on® Roll Cab
VF9500GSB-UY	9500 - Foam Only (Blue over Yellow)

### Complete Set 6

Includes more than 1000 pieces with complete Tool Control Foam System.

Stock No.	Description
9600GSO	9600 - Tools Only
KRL722BPBO	Snap-on® Roll Cab
KRL791APBO	Snap-on® Top Chest
VF9600GSB-UY	9600 - Foam Only (Blue over Yellow)

#### Shown:

- Blue Over Yellow (-UY)

#### Other Foam Colors Available:

- Yellow Over Red (-YR)
- Black Over Red (-BR)
- Black Over Yellow (-BY)

- Storage units can tip or strike you
- Do not open more than one loaded drawer at a time
- Keep children away
- Apply brakes on locking casters when not moving unit
- Do not step in or on drawers
- Secure units together with fasteners
- Read safety precautions on pages W1 to W4

### Intermediate Sets

(in blue over yellow tool control foam)

We offer many choices so you can find the system that best fits your exact needs.

#### Choose from a variety of ideas:

- Complete Tool Sets
- Tool Control Systems
- Tool Control Foam Inserts
- Portable Tool Control Systems
- High Visibility Tools
- Silhouetted Tool Boards
- Wall Cabinets
- Tool Cabinet Accessories



9200AGSO  
Shown with KRA4059FPBO



9600GSO set in KRL791APBO  
Tool Chest and KRL722BPBO  
Tool Cab (U.S. Set 6)



- Must wear eye protection
- Read safety precautions on pages W1 to W2



# TOOL CONTROL SET BUILDING

ORGANIZATION

## U.S. Tool Control Set Building: Complete Tool Set

Configuration sets are available with tool storage and tool control foam

See below for ordering information for each configuration

9100 SERIES	9100GSO	9100GSBO	9100GSBFMBRO	9100GSBFMBYO	9100GSBFMUYO	
<b>Description</b>	U.S. Apprentice set tools only	U.S. Apprentice set tools and tool storage	U.S. Apprentice set including tool storage with black over red tool control foam	U.S. Apprentice set including tool storage with black over yellow tool control foam	U.S. Apprentice set including tool storage with blue over yellow tool control foam	
<b>CONTENTS</b> Refer to pages N011-N023 for descriptions and listings for all tool sets		KRA2055FPBO	VF9100GSB-BR	VF9100GSB-BY	VF9100GSB-UY	
			KRA2055FPBO	KRA2055FPBO	KRA2055FPBO	
9200 SERIES	9200AGSO	9200GSB	9200GSBFMBR	9200GSBFMBY	9200GSBFMUY	9200GSBFMYR
<b>Description</b>	U.S. Set 2 tools only	U.S. Set 2 including tools and tool storage	U.S. Set 2 including tool storage with black over red tool control foam	U.S. Set 2 including tool storage with black over yellow tool control foam	U.S. Set 2 including tool storage with blue over yellow tool control foam	U.S. Set 2 including tool storage with yellow over red tool control foam
<b>CONTENTS</b> Refer to pages N011-N023 for descriptions and listings for all tool sets		KRA4059FPBO	VF9200GSB-BR	VF9200GSB-BY	VF9200GSB-UY	VF9200GSB-YR
			KRA4059FPBO	KRA4059FPBO	KRA4059FPBO	KRA4059FPBO
9300 SERIES	9300GSO	9300GSBO	9300GSBFMBRO	9300GSBFMBYO	9300GSBFMUYO	
<b>Description</b>	U.S. Set 3 tools only	U.S. Set 3 including tools and tool storage	U.S. Set 3 including tool storage with black over red tool control foam	U.S. Set 3 including tool storage with black over yellow tool control foam	U.S. Set 3 including tool storage with blue over yellow tool control foam	
<b>CONTENTS</b> Refer to pages N011-N023 for descriptions and listings for all tool sets		KRA4008FPBO	VF9300GSB-BR	VF9300GSB-BY	VF9300GSB-UY	
		KRA4059FPBO	KRA4008FPBO	KRA4008FPBO	KRA4008FPBO	
			KRA4059FPBO	KRA4059FPBO	KRA4059FPBO	
9400 SERIES	9400GSO	9400GSBO	9400GSBFMBRO	9400GSBFMUYO		
<b>Description</b>	U.S. Set 4 tools only	U.S. Set 4 including tools and tool storage	U.S. Set 4 including tool storage with black over red tool control foam	U.S. Set 4 including tool storage with blue over yellow tool control foam		
<b>CONTENTS</b> Refer to pages N011-N023 for descriptions and listings for all tool sets		KRL751PBO	VF9400GSB-BR	VF9400GSB-UY		
		KRL756CPBO	KRL751PBO	KRL751PBO		
			KRL756CPBO	KRL756CPBO		
9500 SERIES	9500GSO	9500GSBO	9500GSBFMBRO	9500GSBFMBYO	9500GSBFMUYO	9500GSBFMYRO
<b>Description</b>	U.S. Set 5 tools only	U.S. Set 5 including tools and tool storage	U.S. Set 5 including tool storage with black over red tool control foam	U.S. Set 5 including tool storage with black over yellow tool control foam	U.S. Set 5 including tool storage with blue over yellow tool control foam	U.S. Set 5 including tool storage with yellow over red tool control foam
<b>CONTENTS</b> Refer to pages N011-N023 for descriptions and listings for all tool sets		KRL751PBO	VF9500GSB-BR	VF9500GSB-BY	VF9500GSB-UY	VF9500GSB-YR
		KRL756CPBO	KRL751PBO	KRL751PBO	KRL751PBO	KRL751PBO
			KRL756CPBO	KRL756CPBO	KRL756CPBO	KRL756CPBO
9600 SERIES	9600GSO	9600GSBO	9600GSBFMBRO	9600GSBFMBYO	9600GSBFMUYO	9600GSBFMYRO
<b>Description</b>	U.S. Set 6 tools only	U.S. Set 6 including tools and tool storage	U.S. Set 6 including tool storage with black over red tool control foam	U.S. Set 6 including tool storage with black over yellow tool control foam	U.S. Set 6 including tool storage with blue over yellow tool control foam	U.S. Set 6 including tool storage with yellow over red tool control foam
<b>CONTENTS</b> Refer to pages N011-N023 for descriptions and listings for all tool sets		KRL722BPBO	VF9600GSB-BR	VF9600GSB-BY	VF9600GSB-UY	VF9600GSB-UY
		KRL791APBO	KRL722BPBO	KRL722BPBO	KRL722BPBO	KRL722BPBO
			KRL791APBO	KRL791APBO	KRL791APBO	KRL791APBO

## Complete Tool Sets

(Please refer to [b2b.snapon.com](http://b2b.snapon.com) for the complete tool listings and add-on options)

See Tool Storage section for available color options.

Set cabinetry and components are subject to change and may not be exactly as illustrated



VISIBILITY

# VISUAL KEYLESS ENTRY TOOL CONTROL

## LEVEL 5<sup>®</sup> TOOL CONTROL SYSTEM

### SNAP-ON<sup>®</sup> VISUAL CONTROL CABINET

#### NOW YOU CAN CLEARLY SEE WHERE YOUR TOOLS ARE

Features a clear, abrasion-resistant polycarbonate window that gives you a full view of your tools for instant accountability and inventory management. Available in 2 sizes, this cabinet can hold up to 100 tools securely with keyed or keyless entry. With an optional rolling cart or rolling cab, you can position the Visual Control Cabinet close to the work so your technicians always have the right tools ready to use.

**L5V5S49PBO**



Shown with optional foam insert and rolling cart L5V5CRTPBO

#### Colors Available



Red	Gloss Black	Royal Blue	Arctic Silver
PBO	PC	PCM	PKS

### FEATURES AND BENEFITS

#### PERFORMANCE

- Visually manage tools at the “Point of Use”
- Available in 34" and 49" sizes for a tool capacity of 70 to 100 tools
- VCC keeps tools chest high within the “strike zone” – reducing the need to bend and stretch for tools
- Full swing door hinge creates unobstructed entry while gas shocks keep the window in the upright position

#### SECURITY

- Makrolon<sup>®</sup> AR Polycarbonate window the same material used in jet fighter cockpits, for “at a glance” tool management and tool security
- Available with standard key locks or eLock keyless entry for maximum security without the need to distribute keys
- e-Lock is programmable for up to 3,000 users and can be networked with LockView<sup>®</sup> software

#### VERSATILITY

- Includes v-stand brackets with three versatile mounting options:
  1. Mount to a wall using the predrilled, 16" on center holes
  2. Mount to an optional 49" rolling cart using the predrilled holes and included hardware
  3. Mount to any 24" deep or larger roll cab using the predrilled holes and included hardware
- Interior tool control options include metal peg board or customized foam layouts
- Available in 4 color selections so you can organize by area, application or types of tools

Visit the Level 5 website to learn more.

[snaponlevel5.com](http://snaponlevel5.com)

TOOL CONTROL



**WARNING**



- Must wear eye protection
- Read safety precautions on pages W1 to W2

# LEVEL5<sup>®</sup>

TOOL CONTROL SYSTEM

## Standard VCC Models

Stock No.	Description
<b>49-Inch Models (~100 Tools)</b>	
L5V5S49	49" Keyed 5S Box w/V-stand
L5VP5S49	49" Keyless 5S Box with V Stand
<b>34-Inch Models (~70 Tools)</b>	
L5V5S34	34" Keyed 5S Box w/V-stand
L5VP5S34	34" Keyless 5S Box with V Stand

## Optional Accessories

Stock No.	Description
<b>Custom Foam Kits</b>	
FOMV5S34BR	34" Foam Kit Black over Red
FOMV5S34BY	34" Foam Kit Black over Yellow
FOMV5S34UY	34" Foam Kit Royal Blue over Yellow
FOMV5S49BR	49" Foam Kit Black over Red
FOMV5S49BY	49" Foam Kit Black over Yellow
FOMV5S49UY	49" Foam Kit Royal Blue over Yellow
<b>Peg Board Kits</b>	
L5V5SPB34-SD	34" Peg Board Kit
L5V5SPB49-SD	49" Peg Board Kit
<b>Rolling Carts</b>	
L5V5SCRT	VTC 5S Cart
<b>LockView<sup>®</sup></b>	
L5LVSG45	Keyless Entry Software - LockView <sup>®</sup>

## Dimensions (inches)

Stock No.	Description
<b>49-Inch Models (~100 Tools)</b>	
External Dimensions (H x L x D)	26.5 x 49.5 x 27
Storage Dimensions (D x L x W)	5.5 x 46.5 x 28.5
<b>34-Inch Models (~70 Tools)</b>	
External Dimensions (H x L x D)	26.5 x 34.5 x 27
Storage Dimensions (D x L x W)	5.5 x 31.5 x 28.5



### Colors Available

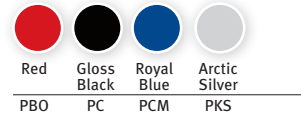

## HOW TO ORDER

1. Select the desired box with v-stand in either 49" or 34", keyed or keyless, and a color option from VCC models.
2. Select color from chart. Add suffix to base stock number.
3. Select interior tool control option, foam cut outs or metal peg board, from optional accessories
4. Select an optional rolling cart from optional accessories\*
5. Add LockView<sup>®</sup> software for networking keyless boxes (one copy per administrator, not per box)

\*KRA2400 series roll cab are also viable options. Reference the Snap-on<sup>®</sup> Industrial website or catalog.



Snap this code with your smartphone to watch the video!

To order product, contact your Account Manager or call the Snap-on<sup>®</sup> Industrial Customer Service Center 1-877-740-1900.  
To view our Industrial website go to [www.b2b.snapon.com](http://www.b2b.snapon.com)



VISIBILITY

# CONFIGURATIONS AND ACCESSORIES

# LEVEL5<sup>®</sup>

TOOL CONTROL SYSTEM

TOOL CONTROL



FOMV5S34BR

## VCC Tool Display Trays & Mounting Kits

Description	49" Stock No.	34" Stock No.
5S Tool Display Tray w/ Pegboard	L5V5S49PB	L5V5S34PB
5S Tool Display Tray	L5V5S49TRAY	L5V5S34TRAY
45 Degree V-stands, Set of 2	L5V5S45VS	
22.5 Degree V-stands, Set of 2	L5V5S22.5VS	

\*Includes Black on Red foam unless specified.  
Kit components are available separately.  
Ask your Account Manager for details.

### 5S Tools Display Tray Kits

Tool Display Tray Kits give you a full view of your tools and include everything you need to mount to a workbench, tool cabinet, or wall. Available in 2 sizes (49" and 34"), with the option of pegboard or a custom foam insert to meet a variety of workplace needs. See your Account Manager for details on custom foam configurations.

### V-Stands

V-Stands allow for custom mounting on a workbench, tool cabinet or wall. Tools can be positioned at the ideal angle for easy access and visibility by choosing between the 45-degree or 22.5-degree V-Stand set.



L5V5S45VS

### VCC Organization Solutions

Description	49" Stock No.	34" Stock No.
Custom Foam Kit*	FOMV5S49BY FOMV5S49UY	FOMV5S34BY FOMV5S34UY
Peg Board	L5V5SPB49-SDA	L5V5SPB34-SDA

\*Available in 3 color options: BR-Black on Red; BY-Black on Yellow; UY-Blue on Yellow



- Must wear eye protection
- Do not use chrome or industrial finish tools with impact drivers
- Keep hands away from pinch points when operating a pneumatic torque wrench
- Read safety precautions on pages W1 to W4

**LEVEL5**<sup>®</sup>  
TOOL CONTROL SYSTEM



**Pegboard Mounting Hardware**

- Wide variety of heavy duty, rubber-tipped, 1/4" steel hook, hanger and clip options

**L5V5S150MHW Pegboard Mounting Hardware (100 Piece)**

**L5V5S70MHW Pegboard Mounting Hardware (70 Piece)**



L5V5S70MHW

**Custom Foam Kits**

Each foam kit includes: Six sheets of top and base foam material, one roll of tracing paper — to custom design and organize your tool drawers.

Royal Blue Over Yellow	Black Over Red	Size, inches (mm)
TCK1827BUY	TCK1827BBR	18 x 27 (457.2 x 508)
TCK4020BUY	TCK4020BBR	40 x 20 (1,016 x 508)
TCK3627BUY	TCK3627BBR	36 x 27 (914.4 x 685.8)

**Bulk Tool Storage**

**At-a-Glance Storage**

- With durable chrome finish and open cage design, it's easy to take inventory of your valuables from any vantage point, without ever entering the cage

**Controlled Security**

- The cage features a keyless entry system and a secondary door handle that latches at the top and bottom so you can control access to the cage
- Convenient padlock security loop allows for easy audit control

**Keyless Entry System**

- Snap-on® Keyless Entry System allows for entry with badge or via keypad with at-the-box programming for up to 3,000 users
- System can be networked with LockView® software

**Easy Access**

- Double doors open to a full 270 degrees for easy access and an unobstructed view of the entire interior

**Storage Versatility**

- Roomy interior features 3 shelves to securely store portable tools, assembly parts or project components

**Portable**

- Portable model feature heavy-duty casters that swivel and lock for easy mobility



<b>Stock No.</b>	<b>L5BSCGP2460</b>
<b>Description</b>	Mobile w/Casters
<b>Country of Origin</b>	USA
<b>Keyless Entry System</b>	Yes
<b>Type of Entry</b>	Badge or Keypad
<b>At-the-Box Programming</b>	Yes
<b>Number of Users</b>	Up to 3,000
<b>Networkable</b>	With LockView® Software
<b>Last Access Identification</b>	Yes
<b>Double-Door Opening</b>	Yes, 270°
<b>Padlock Door Latch</b>	Yes
<b>Total Load Capacity</b>	900 lb
<b>Swivel and Locking Casters</b>	Yes
<b>Durable Chrome Finish</b>	Yes
<b>Outside Dimensions (W x D x H)</b>	62 x 28.5 x 68"
<b>Inside Dimensions (W x D x H)</b>	60" x 24" x 56"
<b>Warranty</b>	2 Year

**Also Available:**

**Bulk Storage Cage Lock Protective Shield  
L5BSLOCKSHLD**

- Protect bulk storage cage lock LED screen and key pad from damage
- Chrome plated, steel wire construction
- Clips on existing lock, no fasteners or modifications required
- Fits Snap-on® L5BSPROXKIT Keyless Entry Cage Lock

**Keyless Entry System Kit, Cage Retrofit  
L5BSPROXKIT**

- Retrofits to most wire cage designs

**Mobile Storage Cage  
L5BSCG2460**

- Without keyless entry

**Keyless Entry Software - LockView®  
L5LVSG5**

- Allows box to be connected to a laptop via USB cable
- See historical logs for box access
- Manage box user settings, group of users and access rights
- Prevent "jackpot" access by locking out boxes after a number to access attempts

**MAXIMUM SECURITY  
Also with Access Control**



**L5BSLOCKSHLD**

Shown with L5BSPROXKIT sold separately.



**L5BSPROXKIT**

## Level 5 LockView® Keyless Entry



# LEVEL5®

TOOL CONTROL SYSTEM

### Level 5 LockView® Keyless Entry

Snap-on's system secures your tool box, allowing you to control who has access to its contents. No keys to lose or share. Administrative access at the unit or through remote software lets you add and delete up to 3,000 authorized users, display an audit trail of past access, and more!

- Grants access to tool boxes with two access methods, Proximity ID card and and/or keypad PIN entry
- Access with single credential or dual credentials
- Battery power makes ideal for environments where tool boxes are on the move
- Powered by 6 D-cell batteries (not included) or power cord – Single set of batteries can last up to six months depending upon environment
- LED lights indicate if box is opened or closed
- At the box programming
- Last access indicator

### L5FPC60SCP Keyless Entry Flammable Liquids

#### Storage Cabinet

- All-welded, 18-gauge, powder-coated steel cabinet provides extra-rigid support for cans and pails
- Double-wall thermal barrier isolates flammable contents from surrounding area
- Dual vents, with built-in steel fire baffles, relieve internal pressure and allow flammable vapor to be piped away
- 2" raised, leak-proof door sill contains leaks and spills
- Keyless entry via badge or keypad, provides maximum security without the need to distribute keys
- LockView® networkable software allows access management from Administrators' PC; manages and monitors access in real time and creates audit trail
- Patented, fail-safe self-closing mechanism automatically closes cabinet after each use or in the event of fire; ensures that doors close tightly from top to bottom
- UL listed; Complies with NFPA Code 30; OSHA Regulations; Uniform Fire Code

### L5KRAPG3 Keyless Entry Retrofit Kit

- Add keyless entry to most KRA/Classic/Heritage roll cabs
- Easy and fast retrofit can be done on-site, on existing boxes
- Each kit includes detailed instructions and box modification templates
- Standard HID proximity card and keypad access

### L5LVSG5 Keyless Entry Software - LockView®

- Allows box to be connected to a laptop via USB cable
- See historical logs for box access
- Manage box user settings, group of users and access rights
- Prevent "jackpot" access by locking out boxes after a number to access attempts

### L5KTCPS Replacement KTC AC Power Supply

# LEVEL5<sup>®</sup>

TOOL CONTROL SYSTEM

## Selection Guide

### How to Order

Level 5 is offered in 13 base unit configurations built on Snap-on<sup>®</sup> KRA Roll Cab platforms. For complete specifications, please see the full-line Snap-on<sup>®</sup> Industrial Catalog.

- Step 1** Determine the base unit requirement based on footprint and capacity
- Step 2** Select color from chart. Add suffix to base stock number.
- Step 3** Order 1 copy of Keyless Entry Software per administrator (usually 1 copy per site).

### 1 - Base Unit

Classic Series KRA Platform	Footprint	Drawer Banks	Number of Drawers	Base Stock No.
KRA2423	73 x 24	3	17	L5KP2418
KRA2432	73 x 24	2	12	L5KP2432
KRA2422	55 x 24	2	10	L5KP2422
KRA2407	55 x 24	1	7	L5KP2407

Heritage Series KRA Platform	Footprint	Drawer Banks	Number of Drawers	Base Stock No.
KRA5311F	53 X 20	2	11	L5KP5311
KRA4813F	48 X 20	2	13	L5KP4813
KRA4107F	40 X 20	1	7	L5KP4107
KRA4008F	26 X 20	1	8	L5KP4008
KRA2007F	26 X 20	1	7	L5KP2007
KRA2005F	26 X 20	1	5	L5KP2005

### 2 - Select Color from chart. Add suffix to Base Stock No.

#### Colors Available

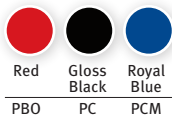

### 3- Software

Stock No.	Description
L5LVSG5	Keyless Entry Software - LockView <sup>®</sup>

To order contact your Account Manager or call the Snap-on<sup>®</sup> Industrial Customer Service Center 1-877-740-1901



- Must wear eye protection
- Do not open multiple drawers
- Images may be shown without actual warning labels
- Read safety precautions on pages W1 to W4

**MASTER SERIES KEYLESS ENTRY**



**LEVEL5<sup>®</sup>**  
TOOL CONTROL SYSTEM

**Keyless Entry Features**

- Access by time, user and date
- How long the user was in the box
- Records unauthorized access attempts by date, time and user
- Records the date, time, and user who performed a physical or visual inventory with findings
- Network-ready with your choice of Ethernet or wireless

- Works with your existing badge system or HID
- Connects to other boxes with slave units to create customized workstations
- Intuitive wizard - driven software provides centralized control for all boxes

**Additional Keyless Entry Features:**

**Power**

- 12V rechargeable battery for extended portability
- Battery level (fuel) gauge in LCD screen
- Messages alert users to recharge
- Indicates charging mode: plugged in, fast-charge or standby mode

**Additional Features**

- Programmable auto-relock time
- System upgradeable to 802.11N
- Supports up to 3,000 active users per box
- At the box programming
- Last access indicator

**Multi-Function Buttons**

- Allow programming at the box
- View all settings, make changes
- View audit trails
- Record visual or physical inventories
- Add and delete users easily

**Technical Support**

- Technical Support is provided through your Account Manager

**Networking**

- Networking allows easy system management from a central location LCD Screen
- Show date, time, user name, battery and system status



Level 5 is offered in eight base unit configurations built on Snap-on<sup>®</sup> KRL Roll Cab platforms. Complete specifications and options are detailed in the following pages.

To order contact your Account Manager or call the Snap-on<sup>®</sup> Industrial Customer Service Center 1-877-740-1900

[b2b.snapon.com](http://b2b.snapon.com) 1.877.740.1900

# LEVEL5<sup>®</sup>

TOOL CONTROL SYSTEM

## Selection Guide

### How to Order

Level 5 is offered in eight base unit configurations built on Snap-on<sup>®</sup> KRL Roll Cab platforms. For complete specifications, please see the full-line Snap-on<sup>®</sup> Industrial Catalog.

- Step 1** Determine the base unit requirement based on footprint and capacity from the chart.
- Step 2** Select color from chart. Add suffix to base stock number.
- Step 3** Choose your networking connections, either Ethernet or wireless.
- Step 4** Order 1 copy of Keyless Entry Software per administrator (usually 1 copy per site).
- Step 5** Choose the accessories that you need for your installation. If you plan to add and connect tool chests, drawer sections and side cabinets to create networked workstations, contact your Account Manager or Customer Service Center for information on slave modules and latches.

### 1 - Base Unit

Platform	Footprint	Drawer Banks	No. Drawers	Base Stock No.
KRL756	35-5/8 x 29"	1	8	L5P756B
KRL1056	35-5/8 x 29"	1	8	L5P1056B
KRL722	54-1/4 x 29"	2	11	L5P722B
KTL1022	54-1/4 x 29"	2	13	L5P1022D
KTL1023	72-7/8 x 29"	3	22	L5P1023D

### 2 - Select Color from chart. Add suffix to Base Stock No.

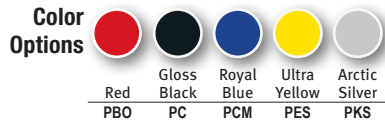

### 3 - Network Connection

Stock No.	Description	Contents
L5ETHERG3	Ethernet Module, Cable	Module with cable one required per box

### 4- Software

Stock No.	Description
L5LVSG5	Keyless Entry Software - LockView <sup>®</sup>

To order contact your Account Manager or call the Snap-on<sup>®</sup> Industrial Customer Service Center 1-877-740-1901

### 5 - Accessories

Stock No.	Description	Contents
L5SUG3	Slave Unit Control	One required per top box or side cabinet
L5KRLPG4	HID Prox Access Panel	Module with cable one required per box
L5BPG3	Battery Box & Batteries	Battery box with batteries and cable
L5PSG3	Power Supply	Replacement power supply with cable
L5YPSG3	Power Connector (back)	
L5KRLPKITG4	HID Retrofit Kit	Complete kit to retrofit a KRL bottom box with HID reader
L5SUAUXG3	Auxiliary Latch Module	-
L5L1PG3	1-Point Side Locker Lock Kit	-
L5L3PG3	3-Point Side Locker Lock Kit	-



- Must wear eye protection
- Do not open multiple drawers
- Images may be shown without actual warning labels
- Read safety precautions on pages W1 to W4

**SAFE & SECURE TOOL MANAGEMENT**



**LEVEL5**  
TOOL CONTROL SYSTEM

**Level 5™ Alpha Roll Cab**

A proven tool control system,  
upgradeable to ATC

**L5P541** (54" Single Bank)

**L5P361** (36" Single Bank)

- Includes keyless entry – Level 5 access control
- Features CAD-developed tool control foam for Level 5™ organization and visibility
- Features 8 full-length drawers
- Features stainless steel top
- Upgradeable to ATC



L5P541ES



**ORGANIZATION**



**VISIBILITY**



**ACCESS CONTROL**



**ASSET MANAGEMENT**

**Color Options**

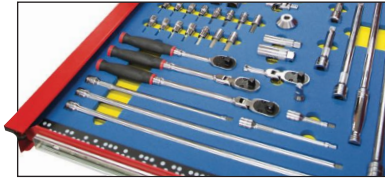
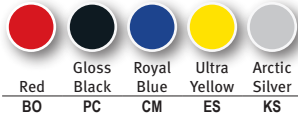

**CAD-Developed Tool Control Foam**

Superior organization for secure tool control management.



**Keyless Entry**

Secure and controlled access with employee badges.

**Upgrade to Automated Control**  
**Contact your Rep today!**

Automated Tool Control Upgrade  
Retrofit your Alpha box with Level 5 ATC top, providing the most advanced tool control system available

Stock No.	Description
L5A0298J30C	Gen4 ATC 36" AC SST
L5A0298J31C	Gen4 ATC 54" AC SST
L5A0298J32C	Gen4 ATC 36" Rechargeable SST
L5A0298J33C	Gen4 ATC 54" Rechargeable SST
L5A0298J35C	Gen4 ATC 36" AC Black
L5A0298J36C	Gen4 ATC 54" AC Black
L5A0298J37C	Gen4 ATC 36" Rechargeable Black
L5A0298J38C	Gen4 ATC 54" Rechargeable Black

**To upgrade, contact your Account Manager:**

- Customer purchases the ATC top
- Stainless top and keyless entry are removed
- ATC top is installed
- Original foam is retained, no upgrade necessary
- ATC administrative software required



**AUTOMATION**

## L5 CONNECT™ SOFTWARE

**L5CONNECT** - Complete software

5 Connect™ software puts you in control of key assets across the facility, designed to enable asset management and compliance, while embracing tool control processes and procedures in your organization.

### Accountability and user productivity

- Control tools and assets across the facility in a single interface
- Track tools that need serialization, calibration, and repair
- Enhance accountability with integrated data analysis tools and audit capabilities
- Quickly assess status across facility in a glance

### Customization to match your workflow

- Configure system structures to accommodate your workflow
- Customize built-in reports to suit your needs
- Implement relevant status monitoring and notifications

### Robust security and seamless integration

Leverage upgrades to security enhancements including latest networks security protocol compatibility

- Windows installers for all L5 Connect family software (Service, Admin Client, Smart Device –Toolbox and Locker, True-Crib)
- Robust REST API for versatile integration

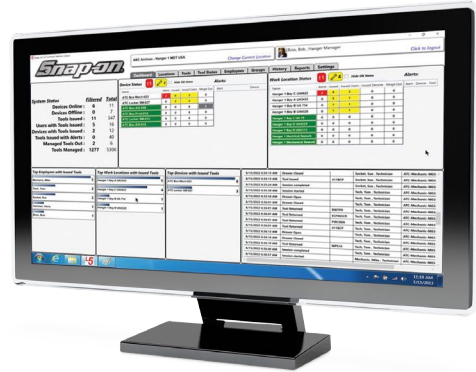

**CONTROL TOOLS AND ASSETS**  
across the facility in a single interface.

## Level 5™ True Crib Software

- Software that talks eliminating the need to repeatedly look at the computer screen between barcode scans
- Fastest, most accurate way to check tools in and out
- Software can communicate with the Snap-on® Keyless Entry System for the ultimate in positive tool control
- Provides audible and visual verification of items and function
- Easy to use, smart and secure



## Tool Management Accessories

- The Snap-on Level 5 Tool Control System offers tool management accessories like Scanning Equipment, Signature Pads, Printers and More to accommodate your workflows and tool control processes.



**Signature Pad**  
L5W1128080



**USB Barcode Scanner**  
L5W3021135



**Label Printer**  
L5W6480135



**Wireless Barcode Scanner**  
L5W6720492



- Must wear eye protection
- Do not open multiple drawers
- Images may be shown without actual warning labels
- Read safety precautions on pages W1 to W4

# LEVEL5<sup>®</sup>

TOOL CONTROL SYSTEM

## Customizable, scalable tool control starts with centralized access control.

Tool control systems control tool shrinkage and replacement cost. They also help reduce lost-tool downtime. In critical industries and applications such as aviation and nuclear power, tool control is an essential step toward eliminating FOD (Foreign Object Damage in aviation) and implementing FME (Foreign Material Exclusion in the power industry). Unlocked and open access tool boxes can result in FOD/FME problems. Snap-on<sup>®</sup> puts you in control with three choices. Our Level 5 Keyless Entry system (N031-N035) allows you to specify access to boxes, audit when they are used, and manage it all over a network.

Our Level 5 ATC system provides the simplest and most user-friendly solution for detecting tools issued from and returned to a tool box, providing a critical enhancement to your FOD/FME program. Using advanced digital imaging technology and proprietary software, the tool box automatically keeps track of its inventory by user, and records which tools are removed and replaced, and when.



### Level 5 ATC Advanced technology that makes tracking tools simple.

Level 5 ATC is a true tool control system. Based on the tool list that you supply, each drawer in the tool box is organized and each tool assigned to a unique space in the foam drawer liner. That information is then programmed into the scanning hardware fitted to the top of the box. As each drawer is opened and closed it is scanned digitally, and the image is instantly compared with the baseline stored image of that drawer. Any tool that has been removed or returned is identified and the computer makes an audible announcement: a tool has been removed or replaced.

Additionally, the computer tracks each tool removed and replaced by its part number and by user, and creates an audit trail in database format. Both the digital images and the data entries are stored for review in an audit trail of the last 15,000 transactions. Not only do you get detailed information, but you have access to the actual pictures of the drawer contents for verification.

### Plug and Play vs. Some Assembly Required

Some solutions to FOD and FME problem involve attaching RFID tags, sensors or bar codes to the tools to track them. Additional operations and attachments can create significant additional cost and limitations by:

- Interfering with the normal use of the tool
- Using up additional real estate in the drawers
- Having limited usability on small tools like sockets
- Dislodging and becoming a new source of FOD

### Level 5 ATC Features

- No individual tool scanning required
- No RFID tags to install or replace
- No limitations on tool size—if it fits in the drawer, it works
- Intuitive interface with easy-to-use touchscreen
- Audible voice confirmation of tool removal and replacement
- Automatic locking
- Large 13.3" monitor
- Errors announced and displayed for incorrect tool position or drawer not closed

The Snap-on<sup>®</sup> Level 5 ATC system is delivered with your predetermined set of tools already installed in one of two basic platforms, the **KRL1056** 36" framework, or the **KRL1021** 54" framework. Each is offered several color choices, three different drawer configuration options, with and without casters, and voltage is 110V and 230V European power per system.

To order, work with your Account Manager or Customer Service Center to determine:

- Tool Set Contents
- 36" or 54" platform
- Color choice
- Drawer configuration
- Casters/no casters
- Standard or extended warranty
- Administrative software, with or without remote HID scanner

Technical Support is just a phone call away! (800) 272-2033



AUTOMATION

# RECHARGEABLE AUTOMATED TOOL CONTROL

TOOL CONTROL

## LEVEL 5<sup>®</sup> TOOL CONTROL SYSTEM

### An automatic tool control system that's as mobile as the work you do.

It's no secret that the Snap-on<sup>®</sup> Level 5 Automated Tool Control System is the most comprehensive program of its kind in the industry. Using advanced digital imaging technology and proprietary software, ATC automatically keeps track of its inventory by user and records which tools are removed and replaced—all in real time. And now, you can take this revolutionary system where you need it, thanks to the on-board rechargeable batteries. Moving ATC closer to the action improves productivity, saving time and money.



### Rechargeable Batteries

Both 36-inch and 54-inch ATC platforms include 6 rechargeable, interchangeable batteries, providing up to 16 hours of battery life (two 8-hour shifts). The hot-swappable feature allows workers to easily replace an existing battery with a charged battery without impacting productivity.

### Recharge Options

Batteries can be fully recharged in 3.5 hours using the internal charging system by plugging in the ATC. An optional, stand-alone battery charger is available which charges up to 6 batteries in 4 hours. Extra batteries are available individually or in a set of 6.

### Safety and Protection

Snap-on<sup>®</sup> rechargeable batteries feature state-of-the-art circuit protection that prevents overload. For safety, the batteries will shutdown if they reach an upper heat limit, (well below critical stages) or if there is an accidental shortage.

### Battery Monitoring

The ATC system monitors the batteries so you don't have to. A visual indicator shows discharge levels and the system verbally announces low battery levels. When batteries are critically low, the ATC system safely shuts down the system and all components.

### Battery Tracking

Each battery is recorded in the ATC system by a serial number and is tracked like a tool. The ATC system records an event each time a battery is removed or replaced.



- Must wear eye protection
- Do not open multiple drawers
- Images may be shown without actual warning labels
- Read safety precautions on pages W1 to W4



# Selection Guide

## How to Order

The Snap-on® Level 5 ATC system is delivered with your predetermined set of tools already installed in one of two basic platforms, 36" or 54". Each is offered in various color choices, three different drawer configuration options, with and without casters, and voltage is 110V and 230V European power per system. To order, work with your Snap-on® Industrial Account Manager or Customer Service Center to determine:

- Step 1** Tool Set Contents—pick the tools you need and we will lay out the drawer arrangements
- Step 2** 36" or 54" Platform—we'll help you pick the right platform based on the number of tools in your set
- Step 3** Select color from chart. Add suffix to base stock no.
- Step 4** Drawer Configuration—pick one of three
- Step 5** Casters—with or without, depending on mobility requirements
- Step 6** Warranty—standard or extended
- Step 7** Order Administrative Software, with Remote HID Scanner

Configuration	36"			54"		
# of Drawers	6	7	8	6	7	8
With Casters Base Stock #	L5AA363	L5AA362	L5AA361	L5AA543	L5AA542	L5AA541
Without Casters Base Stock #	L5AA3S3	L5AA3S2	L5AA3S1	L5AA5S3	L5AA5S2	L5AA5S1

**Color Options**

Red BO	Gloss Black PC	Royal Blue CM	Ultra Yellow ES	Arctic Silver KS	Candy Apple Red JH	Extreme Green JJ	Electric Orange JK

## Software

Administrative software with employee badge scanner.

## Features and Specifications

- 1 year electronics warranty
- Extended warranty available
- 110V/230V AC power required
- Unlimited number of assigned users
- Networking through Ethernet or wireless
- 1 copy of ATC software required for each administrator

## Accessories

- KACL536PC** Cover for 36" Standard ATC
- KACL554PC** Cover for 54" Standard ATC
- KACL536RCPC** Cover for 36" Rechargeable ATC
- KACL554RCPC** Cover for 54" Rechargeable ATC
- L5A0298J21B** Battery Charger
- L5A0298J20A** 6 Pack Batteries
- L5A0298J19A** Individual Batteries

## Protect Your Investment with a Snap-on® Extended Warranty

Snap-on® offers one, two and three year Extended Warranties that will help keep your system fully mission capable, and includes services such as software updates, extra foam cutting and annual inspections

## Platform Available

- 36" single bank roll cab, approximate capacity 450 tools
- 54" single bank roll cab, approximate capacity 750 tools

Contact Your Account Manager for Part Numbers and Pricing.



AUTOMATION

# RECHARGEABLE AUTOMATED TOOL CONTROL

TOOL CONTROL



## Selection Guide

### Create Your Ideal System

The Snap-on® Level 5 Rechargeable ATC system is delivered with your predetermined set of tools already installed in one of two basic platforms, 36" or 54". Each is offered in up to four different drawer configurations and various color choices.

Configuration	36"				54"			
# of Drawers	6	7	8	9	6	7	8	9
Drawer Layout								
Base Stock No.	L5ARC363	L5ARC362	L5ARC361	L5ARC360	L5ARC543	L5ARC542	L5ARC541	L5ARC540

**Color Options**

Red	Gloss Black	Royal Blue	Ultra Yellow	Arctic Silver
BO	PC	CM	ES	KS

Select color from chart. Add suffix to Base Stock No.

Note: 9 drawer configuration is only available in Red and Royal Blue

### ATC Portal

Provides a secure, accurate, and flexible self-service inventory tracking experience.

A turnkey system of radio frequency identification (RFID) readers placed at a choke point, to track movement of RFID tags in and out of a controlled area for inventory management.



L5ATCPORTAL



- Must wear eye protection
- Read safety precautions on pages W1 to W4

# TOOL MANAGEMENT



## Take ATC to the Next Level

Track Specific “Serialized, Certified and Calibrated” Assets such as torque wrenches, calipers & gauges with the ATC ZoomID Detection System. Tags are read/scanned and recorded by the ATC Box cameras like a barcode. Each adhesive tag has a unique color and number sequence. (65,000 unique tag codes available). Plus, get an immediate visual of your tool control status with the FastFlag Status Display Lights System. This add-on works with your existing ATC software to give you feedback in real time.

## ZoomID - Automated Tool Detection System for ATC

### Color Barcoded Tags

- Tags adhere directly to the tool, without interfering with the tools fit or function
- Uses current ATC Gen4 hardware and L5 CONNECT software platform
- 65,000 unique tag codes available

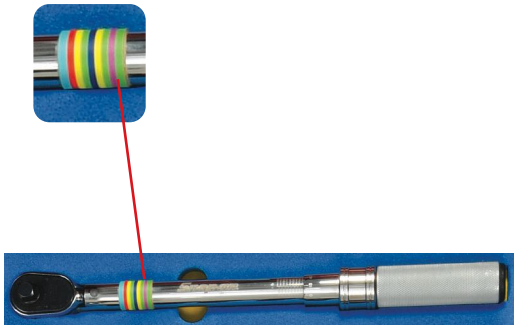

Stock No.	Kit Type	# of Tags
L5TAG01J00A	Starter Kit	212
L5TAG01J01A	Small Kit	212
L5TAG01J20A	Starter Kit	497
L5TAG01J21A	Medium Kit	497
L5TAG01J30A	Starter Kit	1,587
L5TAG01J31A	Large Kit	1,587
L5TAG01J40A	Add-on Kit	162
L5TAG01J41A	Add-on Kit	162
L5TAG01J50A	Add-on Kit	602
L5TAG01J51A	Add-on Kit	602
L5TAG01J52A	Add-on Kit	602
L5TAG01J70A	Add-on Kit	360
L5TAG01J71A	Add-on Kit	360
L5TAG01J72A	Add-on Kit	360

More Tag options available, see Tool Tag Catalog TL5TAG01J00A4 or call your Account Manager.

### Tag Reading Software (Sold per ATC box)

Contact Your Account Manager for Part Numbers and Pricing.

## FastFlag Status Display Light System for ATC



**Status Light**  
Provides Visual Feedback, in Real Time

**Red Light**  
Alert, Tools with Status, Wrong Tool, Bad Drawer Scan, Service Connection Lost

**Yellow Light**  
Box Unlocked, Tools Issued

**Green Light**  
All Tools Present, No Alerts, Box Locked

### FastFlag Status Display Light System for ATC

#### L5FASTFLAG

- Status Light - Provides visual feedback in real time
- Red Light Alert - Tools with status, wrong tool, bad drawer scan, service connection lost
- Yellow Light - Box unlocked, tools issued
- Green Light - All tools present, no alerts, box locked
- Kit includes light, mounting hardware and installation manual

# LEVEL5<sup>®</sup>

TOOL CONTROL SYSTEM

## Level 5 ATC Locker

Automated Asset Management at the Speed of Work

- Fully networkable and scalable with other Level 5™ ATC units; customizable reporting options
- Advanced RFID technology and proprietary software issues and records returns of Critical Industry workplace assets in real-time
- Track irregularly shaped items like extension cords, tools kitted in plastic or fabric carrying cases, personal protective equipment and more

- Heavy-duty metal shelves with foam bear the weight of larger tools and assets
- Track serialized items like torque wrenches, multimeters, micrometers, etc.
- Onboard current allows for secure recharging and storage of power tools
- Connects to Level 5™ administrative interface with same look/feel of operation







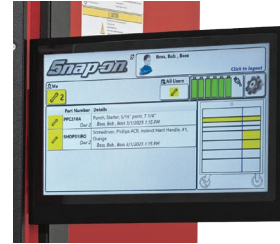

L5331J00CPBO

Illustration shown with tools (Tools not included).



TOOL CONTROL

### Color Options

						
Red	Black	Royal Blue	Ultra Yellow	Electric Orange	Extreme Green	Arctic Silver
PBO	PC	PCM	PES	PJK	PJJ	PKS

## ATC Locker Ordering and Install Process

1. Select Locker by Color and Location (NA/North America/US L5331J00CXXX, EU/Europe L5331J02CXXX)
2. Order Admin Software, One per Location includes card scanner. Contact Your Account Manager for Part Numbers and Pricing
  - If the customer already owns ATC boxes they DO NOT need to order new software, just update
3. Order RFID Starter Kit by Location (Domestic or International)
  - L5A0331J62B Domestic or L5A0331J63A International
  - Includes a variety of tags, adhesive and shrink tube
4. Optional (Highly Recommended)-RFID tag Reader L5A0331J20A
  - Installer will have one for initial install, customer will need one for future tag additions or tag replacements
5. ATC Install Techs will do initial set up of locker and item tagging



- Must wear eye protection
- Read safety precautions on pages W1 to W4

**PORTABLE TOOL STORAGE**



**Mobile Tool Case with Drawers**

**ECNAISNAPON**

- Configurable drawer layout with three interchangeable drawer sizes – 1", 2" or 3" (sold separately)
- Assortment boxes included hidden under removable top compartment tray
- Sealed waterproof design, with a pressure relief valve to regulate internal pressure during altitude changes
- Stackable design with two side handles and top handle for easy and safe lifting
- Includes rear wheels and telescoping handle for portability (optional pivoting 4-wheel adapter kit available separately)
- Drawers include positive stops to prevent inadvertent removal
- Keyed locking system with three padlock points for added security
- Weighs 33 lbs. empty, with 100 lb. maximum capacity; black

**Mobile Tool Case Accessories**

- Positive stops to prevent inadvertent drawer removal
- Made of strong and durable copolymer polypropylene

**ECNAIDRAW3.E 1" Drawer**

- 19.3" w x 12.1" d x 1.1" h

**ECNAIDRAW9.E 3" Drawer**

- 19.3" w x 12.1" d x 3.74" h

**ECNAIWHEELS Mobile Wheel Kit**

- Four pivoting wheels; 2 brakes

**ECNWL01 Plastic Assortment Box 6 Compartments**

- Clear plastic with 6 individually divided compartments
- 6-1/2" L x 4-5/8" W x 1-1/8" D

**ECNWL02 Plastic Assortment Box 13 Compartments**

- 6-1/2" L x 4-5/8" W x 1-1/8" D

**ECNWL04 Plastic Assortment Box 10 Compartments**

- 9-5/8" L x 5" W x 1-1/8" D



**ECNROCKSNAP**

**Mobile Tool Case**

**ECNROCKSNAP**

- Made of High Density Polyethylene, for strength and durability
- Provided with two tool pallets with elasticated loops, with bulk storage space below each pallet.
- Telescoping handle and 3-3/4" polymer wheels for ease of portability
- Includes two TSA keyed locks
- Includes rear wheels and a telescoping handle for portability
- Document holder and two small assortment boxes included
- Keyed locking system
- 33 lbs. empty, with a 100 lb. load capacity
- Exterior Dimensions 22-7/8" W x 17-15/16" H x 15" D

**3-Drawer Blow Molded Portable Chest**

**KRP183**

- They are made of durable, blow-molded polymer with a spacious top compartment to store larger items, plus three steel drawers to organize tools
- Drawers open and close smoothly on heavy-duty steel drawer glides
- Security features include drawers that lock when the lid is closed
- 13.9 lbs; 23" L x 10" W x 13.5" H
- Top compartment 22" L x 8.5" W x 5" H;
- Drawers 18" L x 7.5" W x 1.75" D



# PORTABLE TOOL STORAGE

TOOL CONTROL

## All Weather Mobile Tool Chest

Stackable for easy transport, even when fully loaded. Its wider wheelbase and telescoping handle makes for more stable and easier transport. Secure latching allows for better security, yet it is easy to use. Accommodates up to 8 drawers, in 2 different sizes, for the greatest flexibility of tool storage. And of course, nothing can protect your tools better from the elements.

### Fully Enclosed Ball Bearing Wheels on Wide Corners

- 22" wheelbase improves stability during transport
- Can open the lid without flipping the box over on its side
- Simple, fast field repair capability reduces downtime
- Solid rubber wheels absorb the shock of rough surfaces

### Four Bar Latches

- Prevents accidental opening
- Can be released with one hand
- Superior to swing latch offered on competitive cases

### Telescoping Trolley Handle

- Comfortable for people between the 5th and 95th percentile height

### Cover Swings Open on Top and Can Be Used As a Seat

- Made possible by durable butterfly hinges with stainless steel hardware
- Passivated stainless steel resists corrosion in harsh environments

### Drawers Fully Extend on Snap-on®'s Proprietary Composite Slides, and Rails

- Loaded drawers extend fully so the entire contents of the drawer may be easily viewed
- Three drawer sizes 1-1/4", 2-3/4" and 3"

### Meets/Exceeds Applicable Standards

- MIL 810 Environmental Resistance and Performance
- MIL 1916 Quality Standard Service Parts Available

## All Weather Open Top Mobile Tool Chest

The same great features as the All Weather Tool Chest but with a Open Top Compartment with Storage Space of 21.2 W x 15.4 H x 3.2 D when lid is closed

**KMOC18610RBK**  
Tools not included

Color Option



Black  
PBK



Stock No. *	Total # of Drawers	# of 1" Drawers	# of 2" Drawers
KMOC18610RBK	7	6	1
KMOC18420RBK	6	4	2
KMOC18230RBK	5	2	3
KMOC18040RBK	4	0	4



**KMC18043POR**



**KMC18062PTN**

Base Stock No.	Total # of Drawers	# of 1" Drawers	# of 2" Drawers
KMC18062	8	6	2
KMC18043	7	4	3
KMC18000	0		

Select color from chart. Add suffix to Base Stock No.

Color Options



Combat Tan Orange Combat Green Black  
PTN POR PGR PBK



## Accessories

Stock No.	Description
KMC18-1DRW	1" Deep Drawer for all Mobile Tool Chests
KMC18-2DRW	2" Deep Drawer for all Mobile Tool Chests
KMC18-3DRW	3" Deep Drawer for all Mobile Tool Chests
JIKMC18-7NS	Nonslip Drawer Liner kit for KMC18043 series only
TCK18043BR	Tool Control Kit for KMC18043

## All-Weather Tool Chest Safety Sling

### WFXTHSSAWTC

- Specially designed to safely hoist the Snap-on® KMC18 series of all-weather tool chests (Approved for use with the KMC18 series only)
- Made by Wear-Flex, the acknowledged leader in the field of synthetic slings for over 40 years
- Heat imprinted sewn-on bad that includes the rated capacity and sling serial number for easy identification to satisfy inspection records
- 500 lb. weight limit
- Includes attached use and care instructions



- Must wear eye protection
- Read safety precautions on pages W1 to W4

# TOOL STORAGE SYSTEM

## One Drawer at a Time

### Safety At Your Fingertips

Snap-on® Drawer Control is an interlocking mechanism that prevents you from opening more than one drawer at a time in each drawer bank. This valuable safety feature helps prevent fully loaded roll cabs from tipping over.

**Drawer Control is available for all Snap-on® Masters Series products. Call your Snap-on® Industrial sales representative for additional information.**

### How It Works

What makes Drawer Control work? A special interlocking mechanism connects all drawer slides within a given drawer bank. When one drawer is opened the interlocking shaft locks all the other drawer slides in the drawer bank, preventing them from opening. When all drawers are closed, the special interlocking mechanism releases all the drawer slides, allowing you to open any single drawer in the drawer bank. Smart AND safe.



### Easy To Order.

STANDARD UNITS with One-Drawer-at-a-Time Feature

Other boxes and colors available through Industrial Customer Service Center

You can order this feature on all new Snap-on® Masters series roll cabs and top chests. To order Drawer Control, simply contact our Industrial Customer Service Center (ICSC).

When all drawers are closed the special interlocking mechanism releases the drawer slides, allowing you to open any single drawer in the drawer bank.



### Drawer Control

Stock No.	Base Unit
KRDC751	KRL751
KRDC756C	KRL756C
KRDC1011A	KRL1011A
KRDC1022D	KRL1022D
KRDC1023D	KRL1023D
KRDC1056C	KRL1056D



When one drawer is opened the special interlocking mechanism connects the remaining drawer slides, preventing them from opening.

\*8-07188-28K KRA Retrofit Kit

Color Options



Gloss Red*	Gloss Black*	Royal Blue*	Ultra Yellow	Electric Orange*	Extreme Green	Arctic Silver	Candy Apple Red
PBO	PC	PCM	PES	PJK	PJJ	PKS	PJH

\* KRA4008 and KRA4007 only available in colors indicated

Complete selection and specifications for Snap-on® Master Series tool storage

[b2b.snapon.com](http://b2b.snapon.com) 1.877.740.1900

**Unprecedented Storage Options to Accommodate Any Storage Need**

**CUSTOMIZE. ORGANIZE. OPTIMIZE.**

- The Williams® Modular Industrial Storage Program is designed, engineered, and built specifically for industrial settings, processes, and systems. Heavy-duty steel construction, innovative safety, and security features, and workplace-specific configurations provide for customizable, scalable storage that meets even the most complex needs.

[www.modularindustrialstorage.com](http://www.modularindustrialstorage.com)

Colors Available:

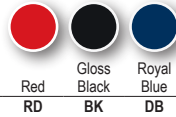

TOOL CONTROL



• Must wear eye protection  
• Read safety precautions on pages W1 to W4



**Available Security Options**

**Lock In/Lock Out Latch**

- Locks individual drawers into position, either closed or fully extended
- Recommended for truck and van storage applications



**Hinged Lock Bar**

- Features padlock hasp for additional protection and security of drawers and contents



**Work Surfaces**

- Available in a variety of shapes and materials





**Features Superior Design & Construction—  
Inside and Out**

- **Fully MIG welded and surface ground** on all eight corners, creating a cabinet that looks as good as it performs
  - **Heavy-duty 11-gauge plug-in guide rail** allows for quick adjustment to accept different drawer sizes and combinations
  - **Heavy-duty 11-gauge carriage** with 6 ball bearing rollers and 4 steel rollers ensures smooth operation of every drawer, even when loaded to the 400 lb. capacity
  - **Full height sidewalls** provide maximum cubic storage capacity, while reducing item spillover into adjacent compartments
  - **Full width 45° angle aluminum handles** for easy identification of contents
  - **Standard full length forklift base** provides a safe platform for installing cabinets or for moving them when reconfiguring workspace
  - **Removable kick panel** combines enhanced safety with a clean look
- (11-gauge fully welded optional pallet truck base available)

**Essential Drawer Features**

- 17 unique drawer sizes/depths
- Drawer heights in 20mm increments

	1	2	3	4	5	6	7	8	9	10	11	12	13	14	15	16	17
<b>Drawer Model Point Value</b>	80	100	120	140	160	180	200	220	240	260	280	300	320	340	360	380	400
<b>Drawer Front Height</b>	3"	3-7/8"	4-3/4"	5-1/2"	6-1/8"	7"	7-3/4"	8-1/2"	9-1/4"	10-1/8"	11"	11-3/4"	12-1/2"	13-1/4"	14-1/4"	14-7/8"	15-1/2"
<b>Drawer Inside Usable Height</b>	2-1/8"	3"	3-7/8"	4-3/4"	5-1/2"	6-1/8"	7"	7-3/4"	8-1/2"	9-1/4"	10-1/8"	11"	11-3/4"	12-3/8"	13-1/4"	14"	14-3/4"
<b>Drawer Side Wall Height</b>	2"	3"	3-7/8"	3-7/8"	3-7/8"	6"	6"	6"	8-1/2"	8-1/2"	8-1/2"	10-7/8"	10-7/8"	10-7/8"	10-7/8"	10-7/8"	10-7/8"

Taller drawers are available. Call your Snap-on® Industrial Account Manager for assistance.  
Drawer Capacity: 400-lbs UDL @ 100% extension

**Safe, Strong & Efficient Drawer Design**

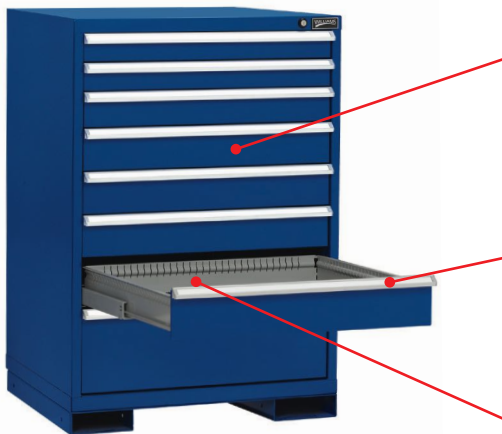

**Riveted Drawer Fronts & Handles**

- Stainless steel rivets provide 650 lbs. of shear strength per rivet for outstanding durability. A minimum of 4 rivets are used to fasten the drawer front to the body and the drawer pull to the drawer front, creating a stronger bond than screws can

**Full-Width Aluminum Handles with Safety Overlap and 45° Angle**

- Overlap helps prevent injury by eliminating sharp edges and pinch points
- Angled design allows improved handle label visibility

**100% View Drawer Extension**

- Full visibility and access to drawer contents via double roller tracks
- Six high-quality steel ball bearings and 4 roller bearings support 400 lbs. per drawer



**Safe Overlapping Handle**

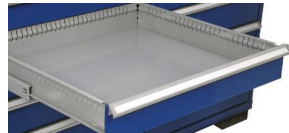

**Supports Up To 400 LBS.  
Per Drawer**



• Must wear eye protection  
• Read safety precautions on pages W1 to W4

**Cabinet Heights & Width Options**

**Choose from Six Cabinet Heights**

The Williams® Modular Industrial Storage Program features a large selection of cabinet housings to meet any demand. Choose from 6 heights to accommodate your company's personnel and space.

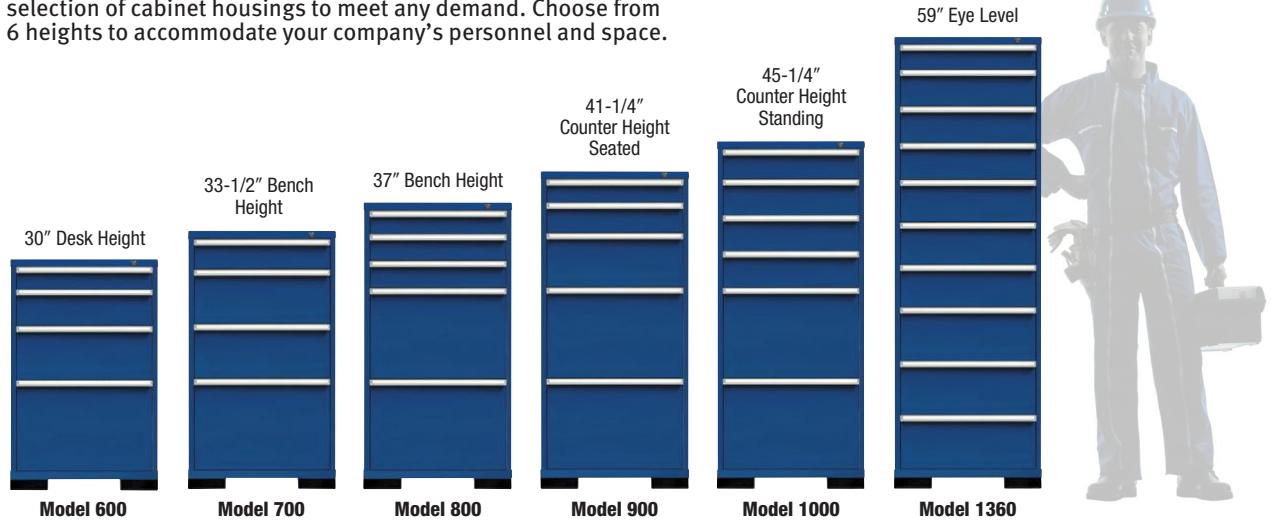

**Choose 5 Five Cabinet Widths**

Cabinets are available in five different widths. Choose widths to accommodate your specific storage needs. All cabinets are 27-3/4" deep and are available in all cabinet heights.

**Narrow-Wide (NW)**

**23" Wide Cabinets**

- Makes excellent work station pedestals or mobile cabinets where space is limited
- Accommodates 18" items



**Standard-Wide (SW)**

**29-1/4" Wide Cabinets**

- Recommended for most applications and provides the fastest pick-rates
- Accommodates items up to 24-1/2"



**Standard-Wide Plus (SWP)**

**32-1/2" Wide Cabinets**

- Recommended for most applications and provides the fastest pick-rates
- Accommodates 28" items



**Extra-Wide Plus (EWP)**

**46" Wide Cabinets**

- Recommended where parts or tools exceed 39"
- Accommodates 42" items

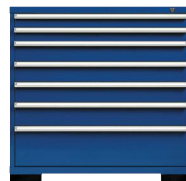

**Double-Wide (DW)**

**58-1/4" Wide Cabinets**

- Recommended for extra-long items
- Accommodates items up to 53-1/2" wide

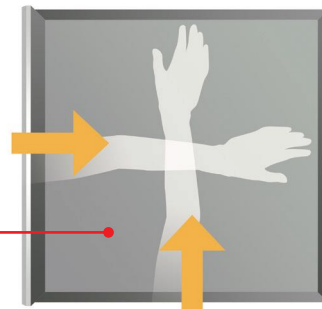
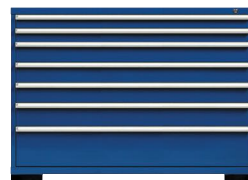

**Human-Engineered Drawers – Square Design**

- The square **Standard Wide (SW) drawer** was ergonomically designed to accommodate the reach of the average person from either the front or the side, increasing picking productivity. Picking stock or retrieving parts from the side keeps aisles clear for increased efficiency and productivity.

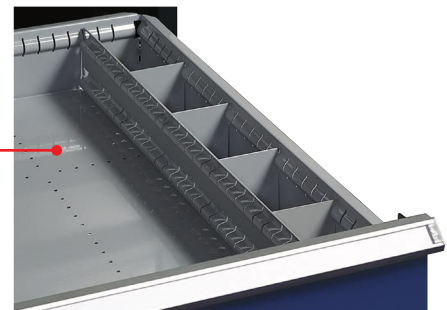

**More Storage Space**

The innovative **Standard Wide Plus (SWP)** cabinet is an exclusive, providing up to 22% more storage than our SW (standard wide) cabinets or competitors' products.

## Drawer Configurations to Meet Every Need

### Choose from five cabinet heights

• Custom configurations are also available. Contact your Snap-on® Representative for details.

#### Desk Height - 30" Tall

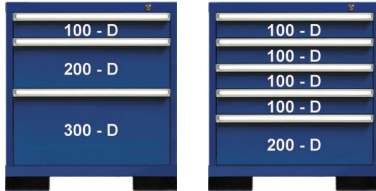

SW600F3DB

SW600F52DB

#### Bench Height - 33" Tall

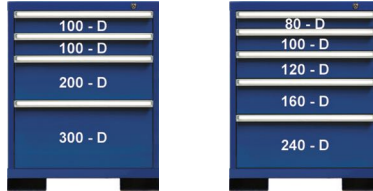

SW700F4DB

SW700F55DB



#### Counter Height (Seated) - 41" Tall



SW900F5DB



SW900F6DB



SW900F74DB



SW900F9DB

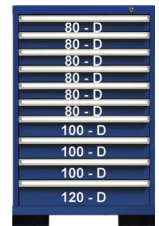

SW900F10DB

#### Counter Height (Standing) - 45" Tall



SW1000F5DB



SW1000F6DB



SW1000F8DB



SW1000F10DB

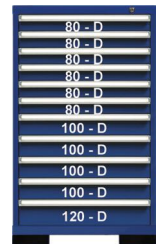

SW1000F11DB

#### Eye Level Height - 59" Tall



SW1360F6DB



SW1360F72DB



SW1360F9DB



SW1360F10DB



SW1360F11DB

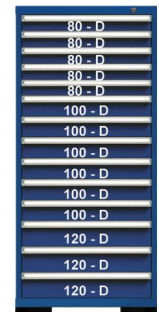

SW1360F14DB



• Must wear eye protection  
• Read safety precautions on pages W1 to W4

Drawer Accessories Maximize Storage Space

Maximum Storage in Minimum Space!

Grooved Plastic Trays and Small Parts Containers

- Drawers are easily configured to perfectly match a wide variety of storage needs, from small parts such as fasteners and connectors, to delicate measuring equipment, cutting tools and electronic parts. Small parts containers and grooved plastic trays create custom layouts and drawer interiors to meet your specific needs.



Grooved Plastic Trays

- Designed to protect side-sensitive tooling
- Available in 3 sizes

SLC50077

- Size 2 (2-7/8")

SLC50078

- Size 3 (1-7/8")

SLC50079

- Size 4 (1-3/8")



SLC50077

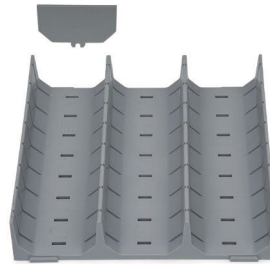

SLC50078



SLC50079



SLCA80A



SLCA80B



SLCN80



SLCN80-DIV



1-1/8

1-7/8

Plastic Bins - A Series

- Modular design made of tough plastic with a usable height of 2"
- Two sizes available

SLCA80A

- 2-1/2" x 2-1/2"

SLCA80B

- 2-1/2" x 5"

Plastic Bins - N Series

- Modular design made of tough plastic with a usable height of 2"

SLCN80

- 6" x 6"

SLCN80-DIV

- 6" x 6" (subdivided into four 3" x 3" compartments)

Label Holders

- Transparent label holders clip onto plastic bins, grooved trays, and steel dividers
- Available in three sizes

SLC50093

- 1-1/8"

SLC50094

- 1-7/8"

SLC50192

- 1-1/8"

## Custom Drawer Layouts for Better Organization



SLC80-P

### Slotted Partitions

- Powder-coated steel partitions subdivide drawers from front to back

Stock No.	SLC80-P	SLC100-P	SLC120-P	SLC180-P	SLC240-P	SLC300-P
Height (inches)	2"	3"	3-7/8"	6"	8-1/2"	10-7/8"
Use with Drawer Number	80	10	120, 140, 160	180, 200	240	300 and up

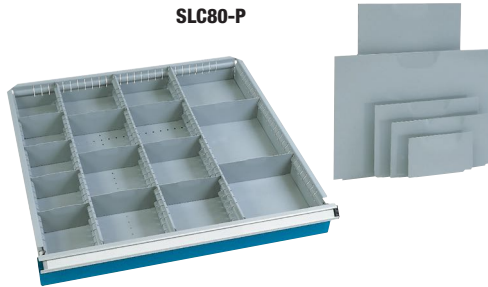

SLC80-P

### Steel Dividers

- Powder-coated steel dividers further separate drawers when used with slotted partitions
- Dividers slide into slots of partitions or drawer sidewalls to form compartments

Usable width of compartment (inches)	1-7/8"	2-5/8"	3-1/2"	4-1/4"	5-1/8"	5-7/8"	7-3/8"	9-1/8"	12-1/4"
Number of units (spaces)	3U	4U	5U	6U	7U	8U	10U	12U	16U

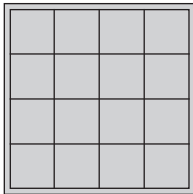

Layout No. 1

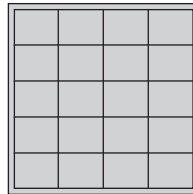

Layout No. 3

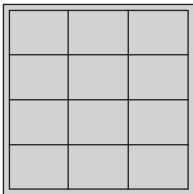

Layout No. 5

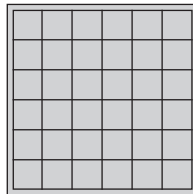

Layout No. 9

### Standard Drawer Layouts

- Most popular drawer layouts shown
- Custom drawer layouts available

#### Layout No. 1

- 16 compartments
- 3 slotted partitions - 12 divider plates 8U

#### Layout No. 3

- 20 compartments
- 3 slotted partitions - 16 divider plates 8U

#### Layout No. 5

- 12 compartments
- 2 slotted partitions - 6 divider plates 10U
- 3 divider plates 12U

#### Layout No. 9

- 36 compartments
- 5 slotted partitions - 20 divider plates 5U
- 10 divider plates 6U

## Options for Even Greater Security and Safety



### Hinged Lock Bar

- Features a padlock hasp for additional protection and security of drawers and contents

### Lock In/Lock Out Latch

- Locks individual drawers into position, either closed or fully extended
- Recommended for truck and van storage applications



• Must wear eye protection  
• Read safety precautions on pages W1 to W4

**More Ways To Customize, Organize, Optimize**

**Shelving Units**

Organize bulky items by adding shelving storage to your cabinets. Their rugged, all-welded construction assures smooth operation, durability and years of dependable heavy-duty service. And because they're adjustable, you can rearrange the shelves to flexibly adapt to your storage needs for years to come.

- **18-gauge shelf** notched to fit snugly around upright posts, preventing small items from falling through any gaps to the shelf below.
- **Powder-coat epoxy paint** baked on to provide a high gloss finish.
- **Shelf reinforcement** adds an additional 400 lbs. of load capacity.
- **Patented 11-gauge shelf support** frames the system and supports heavy loads.
- **Clear Vue doors** (optional) made from plexiglass keep your equipment in sight and secure.

**Choose From Various Sizes**

Shelving units are available in different widths, depths and heights to meet your specific storage needs.

**Widths:** Narrow-Wide (NW) – 23-1/4"  
 Standard-Wide (SW) – 29-1/4"  
 Standard-Wide Plus (SWP) – 32-1/2"

**Depths:** Shallow-Depth (SD) – 23-1/2"  
 Standard-Depth (S) – 27-3/4"

**Heights:** 78" and 84"

**Choose Options and Accessories**

Select between shelves and drawers, or a combination of the two, for the interior. You can also further customize the shelving unit with solid doors, Clear Vue doors, a fork lift base and extra shelves. Available in standard colors of Dark Blue (DB), Red (RD), and Black (BK).

**Workstations**

Every workplace needs a place to work. We deliver highly customizable workstations to fit your specific needs. They can be stationary or mobile, can have shelves, cabinets, or risers, and can be topped with a variety of work surfaces. You can even add footrests. With this much customization, you'll be able to get the job done...your way.

**Tops**

- Solid maple work surfaces are available in a variety of shapes and sizes
- Stainless tops also available upon request

Stock No.	Description
NWMAPLETOP	NW Maple Top 30D X 24L
SWMAPLETOP	SW Maple Top 30D X 30L
SWPMAPLETOP	SWP Maple Top 30D X 33L
EWPMAPLETOP	EWP Maple Top 30D X 48L
DWMAPLETOP	DW Maple Top 30D X 60L
MAPLETOP3048	Maple Top 30D X 48L
MAPLETOP3060	Maple Top 30D X 60L
MAPLETOP3072	Maple Top 30D X 72L
MAPLETOP3090	Maple Top 30D X 90L

**Handles & Wheels**

- Make your storage mobile with our selection of handles and wheels

Stock No.	Description
SLC50226	Caster Kit Set 4
SLC50227	Caster Kit Set 4 and Handle Kit



Shown with optional drawers and Clear Vue doors

SW78FS2D5DB



SW78FS2D5DB-CV

Colors Available:

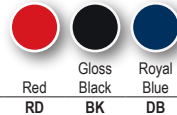

**Available in a range of lengths**

- Available in 48", 60", 72", 84", 90", 120" and 144"
- Fully welded and crafted out of heavy gauge steel
- Supports up to 25,000 lbs
- Riser shelves are available in steel (painted or stainless) or maple.
- Mobility workstations let you bring the work environment to the job, instead of going back and forth to and from the workstation

**Build It Your Way**

- Workstations are available in five heights and can be configured with various options such as an open leg or panel leg, casters, steel or maple work surfaces, risers, drawers, and more.



**OLEG700-FRS24-SW700F55DB-WSMAPBT6030-FA**  
 Workbench with one bench leg and pedestal break-down

OLEG700 = Open Leg (33-1/2" high)  
 FRS24 = Footrest Stringer 24" wide  
 SW700F55DB = Standard Wide, forklift base, 5 drawers, blue  
 WSMAPBT6030 = Workstation Maple Bench Top 60"L x 30"D  
 FA = shipped factory assembled



SLC50227



VISIBILITY

# LASER ENGRAVERS

TOOL CONTROL



LASV10W

## Laser Engravers

The LASV10W and LASV20W Systems are the latest in cutting-edge fiber laser technology for industrial laser marking/ID/traceability applications. The characteristic of this laser system is the excellent beam quality necessary for marking/engraving a broad range of materials. This system requires no chemicals during use, simplifying operations, and eliminating the need for potentially hazardous materials and special handling. No MSDS is necessary.

- Best results on any metal: steel, titanium, aluminum (bare, anodized or coated), as well as plastics (such as ABS, Lexan, PES, PET, PVC), polycarbonate and more.
- Applications include tools, automotive, aerospace, medical device, electronics, semiconductor, corporate jewelry awards, firearms manufacturing, and many more.

Stock No.	Description
LASV10WPAC	10W Laser Engraver Package
LASV20WPAC	20W Laser Engraver Package
LASRING.DIV	STEPPER MOTOR DRIVEN ROTARY DE
LASV10W-PD	PNEUMATIC DOOR LASV10W/20W
LASV10W-TRN	On-Site TRAINING AND INSTALLATION CONUS 10W/20W

Laser Engraver package includes: LASER, MOBILE BASE, FUME EXTRACTOR, POWER CONDITIONER, VIRTUAL SET UP, Shipped to CONUS address.



All units work on both 110 and 230 Volts, 50/60 Hz • Snap-on® Industrial follows a policy of continuous product improvement.

- Specifications are subject to change without notice.
- LASV10W is a class 4 laser source. Laser interaction with organic or inorganic material can cause TOXIC FUMES and PARTICLES.
- The operator shall provide interlocks, indicators and other appropriate safety features, in full compliance with 21 CFR 1040 and/or other applicable national and local regulations.



- Must wear eye protection
- Read safety precautions on pages W1 to W4

# PORTABLE TOOL STORAGE



## Micro Cases

Great for rugged activities - not for swimming or submerging.

- Easy open latch, includes carabiner
- Stainless steel hardware with rubber liner that doubles as O-ring seal
- Water resistant, crushproof, and dust proof
- Automatic Pressure Equalization Valve balances interior pressure, keeps water out



PCD1020100

Specifications	PCD1020100	PCD1040100	PCD1060100
<b>Exterior Dimensions</b>	6.82 x 4.75 x 2.12" (17.3 x 12.1 x 5.4 cm)	7.50 x 5.06 x 2.12" (19 x 12.8 x 5.4 cm)	9.37 x 5.56 x 2.62" (23.8 x 14.1 x 6.7 cm)
<b>Interior Dimensions</b>	5.31 x 3.56 x 1.68" (13.5 x 9 x 4.3 cm)	6.50 x 3.87 x 1.75" (16.5 x 9.8 x 4.4 cm)	8.25 x 4.25 x 2.25" (20.9 x 10.8 x 5.7 cm)
<b>Weight</b>	0.55 lb (0.25 kg)	0.7 lb (0.32 kg)	1 lb (0.45 kg)



PCD1450130

PCD1460110

PCD1510110

PCD1520110

PCD1550110

## Medium Cases

- Open cell core with solid wall design is strong, light weight, watertight, crushproof, and dust proof
- Easy open Double Throw latches and O-ring seal with Automatic Pressure Equalization Valve
- Comfortable rubber over-molded handle and stainless steel hardware and padlock protectors
- Cases do not include tools or foam inserts \* Model 1510 Carry-On Case is the FAA maximum carry-on size, and includes retractable handle and wheels with stainless steel bearings



OD Green



Yellow

\*Model 1510 Carry-On Case is the FAA maximum carry-on size, and includes retractable handle and wheels with stainless steel bearing

Model	Stock No.	Color	Exterior Dimensions	Interior Dimensions	Lid/Bottom Depth, inches (cm)	Weight
1450	PCD1450110	Black	16.00 x 13.00 x 6.87" (40.6 x 33 x 17.4 cm)	14.62 x 10.18 x 6.00" (37.1 x 25.8 x 15.2 cm)	1.75/4.25 (4.4/10.8)	5.51 lb (2.5 kg)
	PCD1450130	OD Green				
	PCD1450240	Yellow				
1510	PCD1510110	Black	22.00 x 13.81 x 9.00" (55.9 x 35.1 x 22.9 cm)	19.75 x 11.00 x 7.60" (50.1 x 27.9 x 19.3 cm)	1.79/5.79 (4.5/14.7)	11.99 lb (5.44 kg)
	PCD1510130	OD Green				
1520	PCD1520110	Black	19.78 x 15.77 x 7.41" (50.2 x 40 x 18.8 cm)	18.06 x 12.89 x 6.72" (45.9 x 32.7 x 17.1 cm)	1.79/4.93 (4.5/12.5)	8.29 lb (3.76 kg)
	PCD1520240	Yellow				
1550	PCD1550110	Black	20.62 x 16.87 x 8.12" (52.4 x 42.8 x 20.6 cm)	18.43 x 14.00 x 7.62" (46.8 x 35.5 x 19.3 cm)	1.75/5.87 (4.4/14.9)	10.58 lb (4.8 kg)
	PCD1550240	Yellow				

## Pelican Large Cases

**PCD1600110**

**PCD1620110**

**PCD1650110**

### Large Cases

- Retractable extension handle and strong polyurethane wheels with stainless steel bearings
  - Open cell core with solid wall design is strong, lightweight, watertight, crushproof, and dustproof
  - Easy open Double Throw latches and O-ring seal with Automatic Pressure Equalization Valve
  - Comfortable rubber over-molded handle and stainless steel hardware and padlock protectors
  - Cases do not include tools or foam inserts
- \* Model 1600 does not include retractable handle or wheels

Model	Stock No.	Color	Exterior Dimensions	Interior Dimensions	Lid/Bottom Depth, inches (cm)	Weight
1600*	PCD1600240	Yellow	24.25 x 19.43 x 8.68" (61.6 x 49.3 x 22 cm)	21.43 x 16.50 x 7.87" (54.4 x 41.9 x 20 cm)	1.75/6.12 (4.4/15.5)	13 lb (5.9 kg)
1610	PCD1610110	Black	24.83 x 19.69 x 11.88" (63 x 50 x 30.2 cm)	21.78 x 16.69 x 10.62" (55.3 x 42.4 x 27 cm)	2.05/8.57 (5.2/21.8)	19.5 lb (8.85 kg)
	PCD1610130	OD Green				
1620	PCD1620110	Black	24.64 x 19.39 x 13.78" (62.6 x 49.2 x 35 cm)	21.48 x 16.42 x 12.54" (54.5 x 41.7 x 31.8 cm)	2.01/10.53 (5.1/26.7)	21.2 lb (9.62 kg)
	PCD1620130	OD Green				
1650	PCD1650110	Black	31.59 x 20.47 x 12.45" (80.2 x 52 x 31.6 cm)	28.57 x 17.52 x 10.62" (72.5 x 44.5 x 27 cm)	1.81/8.84 (4.6/22.4)	24.03 lb (10.9 kg)
	PCD1650130	OD Green				

**WARNING**

- Must wear eye protection
- Read safety precautions on pages W1 to W4



**Pelican Storm Cases**

- Press & Pull Latches, double-layered, soft-grip handle, padlockable hasps, and Vortex® Valve
- Built to withstand impact, temperature, moisture, and rough transit
- Anti-shear teeth keep lids from shifting during impact
- Uniquely designed hinges with feet to allow sturdy upright standing
- Cases furnished in black. For other color options, contact your Snap-on® Industrial Representative

Stock No.	Interior Dimensions L x W x H inches	Exterior Dimensions L x W x H inches	Empty Weight (lb)	Wheels	Retractable Handle	Airline Carry-on	NSN Available
HIM20500000	9.5 x 7.5 x 4.25	11.8 x 9.8 x 4.7	2.7	No	No	Yes	Y
HIM21000000	13 x 9.2 x 6	14.2 x 11.4 x 6.5	4.2	No	No	Yes	Y
HIM22000000	15 x 10.5 x 6	16.2 x 12.7 x 6.6	4.9	No	No	Yes	Y
HIM23000000	17.0 x 11.7 x 6.2	18.2 x 13.4 x 6.7	5.8	No	No	Yes	Y
HIM24000000	18.0 x 13.0 x 6.7	19.2 x 15.2 x 7.3	6.5	No	No	Yes	Y
HIM25000000	20.5 x 11.5 x 7.2	21.7 x 14.1 x 8.9	11	Yes	Yes	Yes	Y
HIM26000000	20.0 x 14.0 x 7.7	21.2 x 16.0 x 8.3	8.5	No	No	No	Y
HIM27000000	22.0 x 17.0 x 8.0	24.6 x 19.7 x 8.6	11.1	No	No	No	Y
HIM27200000	22.0 x 17.0 x 10.0	24.6 x 19.7 x 11.7	16.8	Yes	Yes	No	Y
HIM27500000	22.0 x 17.0 x 12.7	24.6 x 19.7 x 14.4	18.5	Yes	Yes	No	Y
HIM29500000	29.0 x 18.0 x 10.5	31.3 x 20.4 x 12.2	20.8	Yes	Yes	No	Y
HIM29750000	29.0 x 18.0 x 13.8	31.3 x 20.4 x 15.5	22.5	Yes	Yes	No	Y
HIM31000000	36.5 x 14.0 x 6.0	39.8 x 16.5 x 6.7	15.2	Yes	No	No	Y
HIM33000000	50.5 x 14.0 x 6.0	53.8 x 16.5 x 6.7	19	Yes	No	No	Y