



HEIGHT GAGES

ELECTRONIC HEIGHT GAGES

2000 ALTISSIMO® ELECTRONIC HEIGHT GAGES

0-24"/600MM

Altissimo® Electronic Height Gages are innovative, easy-to-use, and loaded with Starrett-exclusive functions for easy-to-program measuring routines that run smoothly and reliably.



FEATURES

- A unique, ergonomically shaped base, hardened and ground, that fits your grip just right to easily move the gage and press the hot key
- Hot key allows you to select measuring results on the fly
- 0-24" Measuring Range
- Smart probe that can measure I.D. or O.D. without attachments
- Electronically adjusted probe force
- Large, easy-to-read interactive LCD with unique scanning meter for monitoring probe position
- Electronically adjustable beeper volume
- Bold screen icons indicate the current routine
- Three electronically adjustable resolutions
- Retains the last calibrated diameter of the measuring probe, even after the gage is shut down
- Dynamic bi-directional probing with point and scan modes
- Easy operation with speed wheel, which also has fine-adjust feature
- Locking mechanism for scribing
- Five measurement modes: (ID/OD, Center, TIR, Max/Min, Continuous Display)
- Instant inch/millimeter conversion
- Two selectable Datums and Presets
- Auto Power Off after two hours with retention of probe calibration
- Automatic calculation of eight measurement routines:
 - Center
 - Diameter
 - Height
 - Max
 - Min
 - TIR
 - Distance to last feature
 - Distance between last two points
- Rechargeable NiMH batteries with 100 hours of continuous life
- Seven setup functions:
 - Probe Calibration (2)
 - Beeper Volume
 - Display Resolution
 - Probe Force Adjustment
 - Printer On/Off
 - Force Calibration
- Optional probe kit features a variety of probes for many applications
- Gages include carbide probe, probe holder and probe calibration block
- RS232 data output port
- Starrett capacitive measurement system ensures the accuracy and reliability you expect
- Excellent value – loaded with features and competitively priced



Large, easy-to-view /understand display shows the diameter of a hole or boss



Display showing TIR



Interactive LCD with unique scanning meter for easy probe position viewing

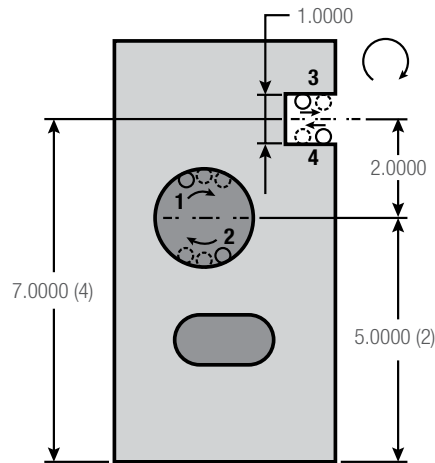

Altissimo includes many routines including diameter of a bore (1 and 2), width of a slot or a rib (3 and 4), distance from datum to center of a hole or slot and distance between features

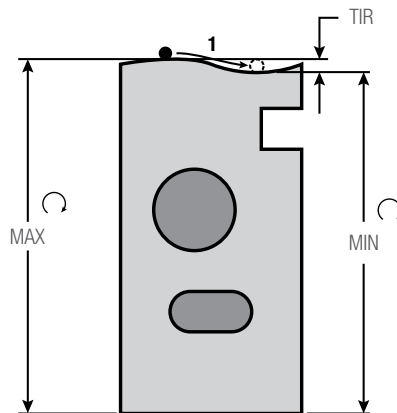

TIR mode can measure the high or low point of a diameter or other surface. The datum can then be set to the max or min value.

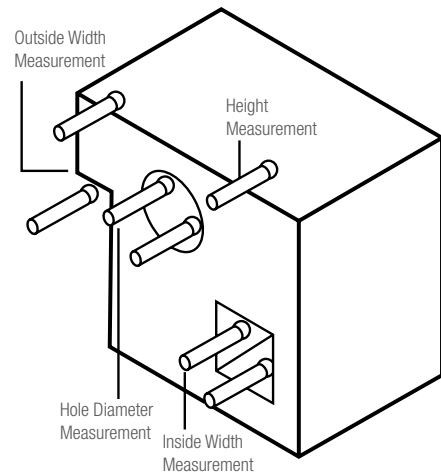

Specifications	
Measuring Range	24"/600mm (Extendible to 30"/750mm by rotating the probe holder 180°)
Resolution	.0001"/.0005"/.001" (0.002mm/0.01mm/0.02mm)
Accuracy	±.0003" (0.008mm)
Repeatability	±.0002" (±0.002mm)
Power Source	NiMH Rechargeable Batteries (120V AC/60Hz Charger/Adapter included). Operation time: 100+ hours, Recharging time: 10 hours
Included	.1875"/4.8mm Dia. Carbide Probe, Probe Holder
Accessories	AC Charger/Adapter, Probe Calibration Block
Dimensions	Length 11" (279mm), Width 7-3/4" (197mm), Height 36-1/2" (927mm)
Weight	40 lb (18 kg)
Perpendicularity	.0004" (0.010mm)



ELECTRONIC HEIGHT GAGES

ALTISSIMO® ELECTRONIC HEIGHT GAGES



Altissimo Electronic Height Gages with Standard Components		
Cat. No.	EDP	Description
2000-24	67008	Height Gage
PT27937	67009	Carbide Probe .1875" (4.8mm) Dia. (Standard)
PT27940	67010	Probe Holder (Standard)
PT27944	67011	Probe Calibration Block (Standard)
Accessories for Altissimo Electronic Height Gages		
Part No.	EDP	Description
S2000AZ	66997	Accessory Set Includes:
PT27948	67012	Probe Tip, 5-Way Adapter
PT23942	65255	.040" (1mm) Carbide Contact Point
PT23914	64222	.078" (2mm) Carbide Contact Point
PT23943	65256	.120" (3mm) Carbide Contact Point
PT27952	67013	Contact Wrench
PT27945	67014	.400" (10.2mm) Cylindrical Probe
PT27950	67015	Circular Carbide Scriber
PT27949	67016	Depth Gage Attachment
PT27946	67017	Holder for Dovetail Indicators
PT62011	67018	Replacement Battery Pack, NiMH 6V
PT62015	67002	Power Supply Charger for USA and Canadian Configuration
PT62130	67003	Power Supply Charger for United Kingdom Configuration
PT62131	67004	Power Supply Charger for European Configuration
2000SCM	69907	Cable to 7612 or 7613 Multiplexer
2000SCKB	69908	USB cable to PC (In focused window)
2000SCU	29728	Cable to PC Running Data Collection SPC Software - USB

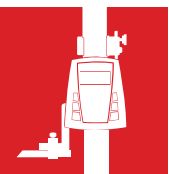

ELECTRONIC HEIGHT GAGES

3751 ELECTRONIC HEIGHT GAGE (WITHOUT OUTPUT)

0-6"/150MM

This height gage is light, portable and easy to use for vertical measurements within its range.

3751 Electronic Height Gage (0-6"/150mm Range)		
Cat. No.	EDP	Description
3751AZ-6/150	12221	Height Gage, in Case
Accessories and Cables for 3751 Electronic Height Gage		
Part No.	EDP	Description
PT99492	65650	One 3-Volt Batteries, CR2032
PT08680A	51383	Depth Attachment for 6" (150mm) Height Gages
947	56756	Wood Case Only



READABILITY FEATURES

- Easy-to-read LCD .32" high characters

ACCURACY AND LONG LIFE DESIGN FEATURES

- Hardened, stainless steel bar for long life
- Depth attachment PT08680A available for measuring depth of holes, slots, and recesses
- Fine adjustment thumb roll for precision measurements
- Rounded nose scriber cuts clean, sharp lines with smoothness and less pressure
- Lock to hold the slide in position
- Hardened, ground, and lapped base with finger grooves provides ease of movement
- Easy access to single long-life battery, 3-volt CR2032
- Vertical bar is back from the edge of the nose for better stability
- Scriber can reference zero from the bottom of the base to get the full 6" (150mm) usable range
- Linear Accuracy: $\pm .001"$ ($\pm 0.02\text{mm}$)
- Resolution: $.0005"$ (0.01mm)

ACTION FEATURES WITH THREE CONTROL BUTTONS

- Inch-millimeter conversion
- Zero at any position
- Manual ON/OFF plus a built in automatic OFF after 5 minutes of nonuse



NEW!

HEIGHT GAGES

ELECTRONIC HEIGHT GAGES

3754 ELECTRONIC HEIGHT GAGES

The 3754 Electronic Height Gage is a full featured, versatile and economic solution for most height measurement applications. All measuring information from these tools can be entered directly into Starrett Data Collection Systems for analysis, data collection and hard copy documentation. It is available in 0-12" and 0-24" ranges.

FEATURES

- Large (.380"/9.65mm), easy to read LCD display reads to .0005" or 0.01mm
- Large positive keypad
- Relative scale
- Fine adjust
- Furnished with two (2) 3-volt batteries (CR2032) and carbide tip scriber
- Improved battery cover

On/Off Button
(auto off after 30 minutes of nonuse)

± Button
Toggles polarity or direction change

Hold Button
Retains current reading at any position

Primary: In/mm
Toggles Inch or metric readout

Secondary: LIMITS
min/max tolerance specifications at any position

Shift Set Button
Toggles between Primary and Secondary Functions

Primary: ZERO/ABS
Toggles Zero at current position or absolute

Secondary: PRESET Button
Install any reading at any position

3754-12/300

3754 Electronic Height Gage				
Cat. No.	EDP	Range	Accuracy	Resolution
3754-12/300	72625	0-12" (300mm)	0.001"	.0005"
3754-24/600	46003	0-24" (600mm)	.002" (>18")	.0005"

Cables, Accessories, Cases for 3754 Electronic Height Gages		
Cat. No.	EDP	Description
PT61120	65446	3-volt battery, CR2032 (2), required
928	55249	Wood case only for 12" gage
945	56684	Wood case only for 24" gage
733SCKB	69888	USB cable to PC (In focused window)
733SCU	69898	USB cable to PC running SPC Data Collection software
733SCM	69893	Cable to 7612 or 7613 Multiplexer

Furnished without case unless otherwise ordered.

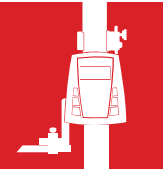

HOW TO READ A STARRETT 50-DIVISION VERNIER HEIGHT GAGE GRADUATED IN INCHES AND MILLIMETERS (DIRECT READING)

INCH READING

- Refer to the left side bar graduations and the inch vernier plate. Inches are numbered in sequence over the full range of the bar. Each bar graduation is .050". Every second graduation between the inch lines is numbered and equals .100".
- The vernier plate is divided into 50 parts, each representing .001". Every fifth line is numbered – 5, 10, 15 ... 45, 50 – for easy counting.
- To read the gage, first count how many inches and how many .050" lines lie between the zero line on the bar and the zero line on the vernier plate and add them.
- Then count the number of graduations on the vernier plate from its zero line to the line that coincides with a line on the bar. Multiply the number of vernier plate graduations you counted by .001" and add this figure to the number of inches and .050" lines you counted on the bar. This is your total reading.

EXAMPLE

- ★ In the photo, the vernier plate zero line is five inches (5.000") plus .750" beyond the zero line on the bar, or 5.750". The 25th graduation on the vernier plate coincides with a line on the bar (as indicated by stars). $25 \times .001$ (.025") is therefore added to the 5.750" bar reading, and the total reading is 5.775".

MILLIMETER READING

- Refer to the right side bar graduations and millimeter vernier plate. Each bar graduation is 1.00mm. Every tenth graduation is numbered in sequence – 10mm, 20mm, 30mm, etc. – over the full range of the bar. This provides for direct reading in millimeters.
- The vernier plate is divided into 50 parts, each representing 0.02mm. Every fifth line is numbered in sequence – 0.10mm, 0.20mm, 0.30mm ... 0.80mm, 0.90mm – providing for direct reading in hundredths of a millimeter.
- To read the gage, first count how many millimeters lie between the zero line on the bar and the zero line on the vernier plate.
- Then find the graduation on the vernier plate that coincides with a line on the bar and note its value in hundredths of a millimeter. Add the vernier plate reading in hundredths of a millimeter to the number of millimeters you counted on the bar. This is your total reading.

EXAMPLE

- ★ In the photo, the vernier plate zero line is 146 millimeters beyond the zero line on the bar, and the 0.68mm graduation on the vernier plate coincides with a line on the bar (as indicated by stars). 0.68 millimeters is therefore added to the 146 millimeter bar reading, and the total reading is 146.68 millimeters.

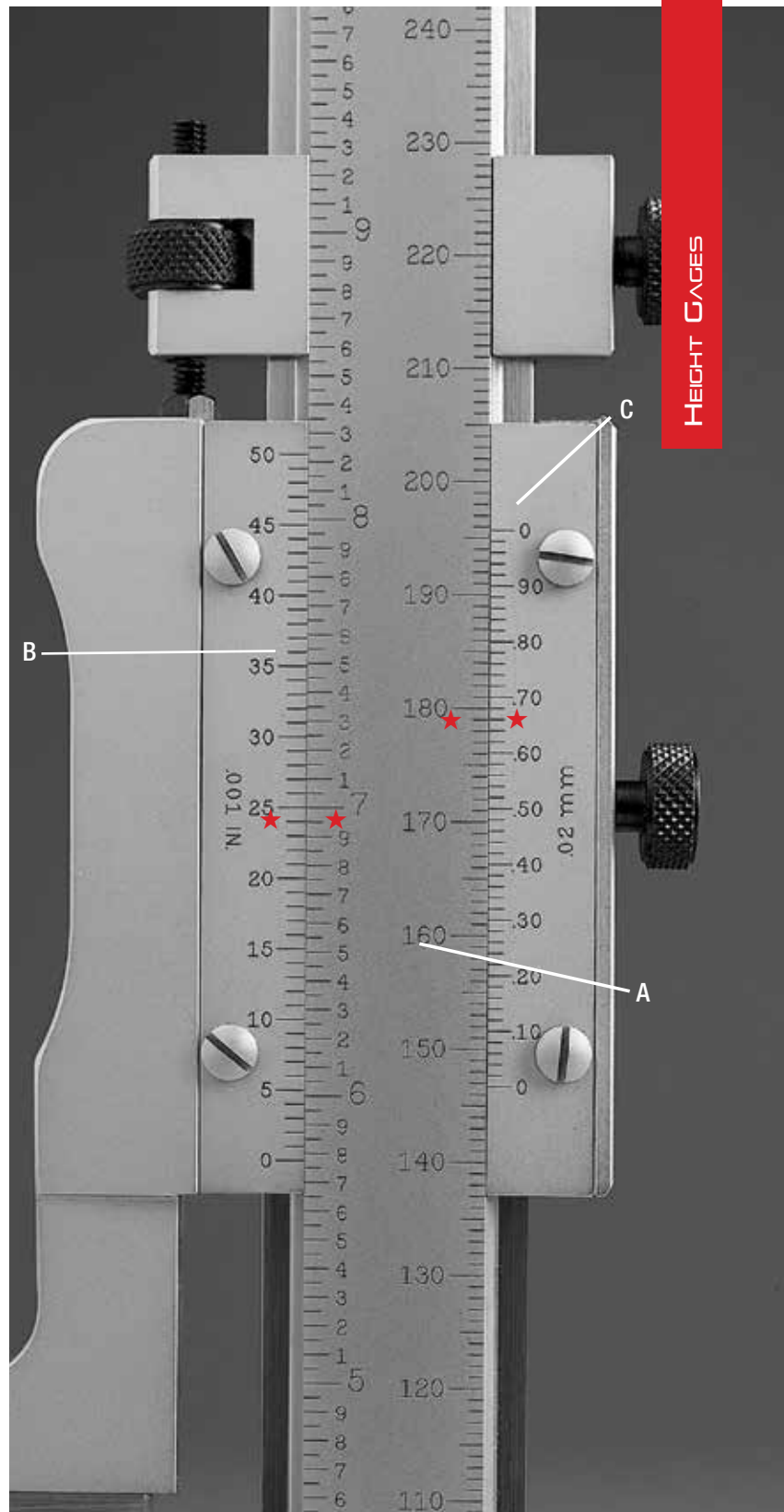

Open-face long Vernier with 50 widely spaced graduations for easy reading. Flush-fitting Vernier and master bar eliminates parallax.

A. Master Bar
B. Inch Vernier Plate
C. Millimeter Vernier Plate



VERNIER HEIGHT GAGES

254, 254M MASTER VERNIER HEIGHT GAGES

0-72"/0-900MM

254EM MASTER VERNIER HEIGHT GAGES

0-24"/0-600MM

This Master Vernier Height Gage is an accurate, rugged and reliable tool that gives precise and dependable measurements over long ranges. It has an easy-to-read vernier, is stronger, and is offered in greater ranges than other height gages.

READABILITY FEATURES

- Long, 50-division vernier scales permits half as many bar graduations as single vernier tools. These widely spaced graduations provide easy reading to .001" or 0.02mm
- Flush fitting of the vernier scales to the main scale eliminates parallax
- Vernier scales are adjustable
- Black lines and figures against Starrett satin chrome finish make reading easy
- Scriber and base are designed for direct reading from zero (bottom of base)

EASE-OF-HANDLING FEATURES

- Quick-adjust release on the slide allows for fast positioning
- Extremely fine adjustments by a knob on the base isolating the column and slide from external pressures
- Additional remote fine adjustment located on top of the bar for sizes 36" (900mm) and larger
- Special master bar design and the balanced design and weight of the base eliminates vibration
- Master bars on models up to 24" and 600mm are hardened and stabilized
- Base is hardened, ground, and lapped square with the bar and has finger grooves to provide ease of movement
- Vertical bar is positioned near the center of the base for balance and stability
- Versatile tool will scribe lines, mount dial indicators or electronic probes, and accept depth attachments
- Tool can also be used with our 359 Protractor for checking angles

254 Master Vernier Height Gages (.001" Graduation)			
Cat. No.	EDP	Range	Approximate Base Dimensions
254Z-12	51219	0-12"	5-7/8" x 3-7/8"
254Z-18	51220	0-18"	7-1/2" x 4-1/2"
254Z-24	51221	0-24"	
254Z-36	51222	0-36"	10" x 6-1/2"
254Z-48	51223	0-48"	
254Z-60	56183	0-60"	
254Z-72	56184	0-72"	
254M Master Vernier Height Gages (0.02mm Graduation)			
Cat. No.	EDP	Range	Approximate Base Dimensions
254MZ-300	56214	0-300mm	150mm x 95mm
254MZ-450	56215	0-450mm	190mm x 115mm
254MZ-600	56216	0-600mm	
254MZ-900	56217	0-900mm	250mm x 165mm
254EM Master Vernier Height Gages (.001"/0.02mm Graduation)			
Cat. No.	EDP	Range	Approximate Base Dimensions
254EMZ-12	51224	0-12"/300mm	5-7/8" x 3-7/8"
254EMZ-18	51225	0-18"/450mm	7-1/2" x 4-1/2"
254EMZ-24	51226	0-24"/600mm	
Accessories for 254, 254M and 254EM Master Vernier Height Gages			
Part No.	EDP	Description	
PT22357	12295	Auxiliary Straight Carbide Scriber	
PT28131	67007	Auxiliary Circular Carbide Scriber	
PT05409A	51227	Depth Gage Attachment	

Hardened bars on all sizes through 24" and 600mm
Furnished with Auxiliary Straight Carbide Scriber. Shown with optional Auxiliary Circular Carbide Scriber.



Quick-adjusting screw release allows rapid slide movement to desired area, then precisely position with the fine adjustment knob



Precise positioning with fine-adjustment knob on the base isolates column and slide from external pressures

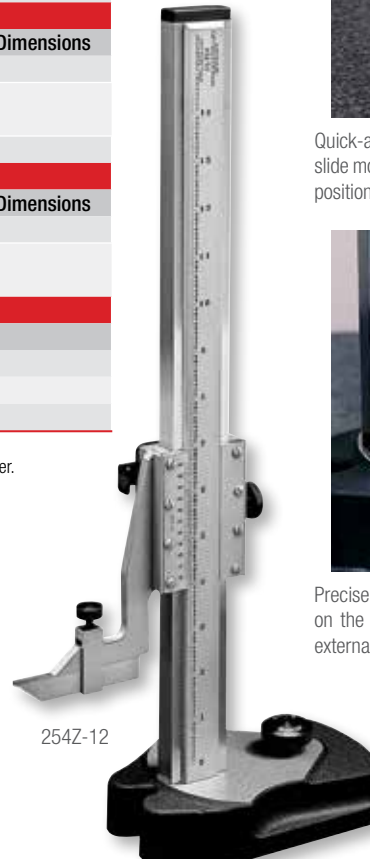

254Z-12

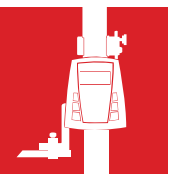

VERNIER HEIGHT GAGES

255, 255M VERNIER HEIGHT GAGES

0-18"/0-300MM

255EM VERNIER HEIGHT GAGES

0-18"/0-450MM

This tool is the "baby brother" of the 254 Master Vernier Height Gage. It is essentially the same tool, but a much lighter version for normal use where heavy duty applications are not practical. The 18" and 450mm models weigh 3-1/4 lb (1.5kg). No other height gage features this favorable combination of design, weight and accuracy.

READABILITY FEATURES

- Long, 50-division vernier scales that can be read to .001" or 0.02mm without a magnifying glass
- Flush-fitting of the vernier scales to the main scale eliminates parallax
- Easy-reading sharp black lines and figures against Starrett satin chrome finish background
- The scribe and the base are designed so that the gage will read directly from zero

EASE-OF-HANDLING FEATURES

- Slides easily for quick adjustment and has a screw type adjusting nut on the bar for precise positioning
- The design of the hardened and stabilized bar plus the balanced design and weight of the base eliminate vibration
- The base is hardened, ground, and lapped and is hand shaped for sure grip and easy movement
- The vertical bar is positioned near the center of the base for balance and stability
- Ability to scribe lines, measure with dial indicators or electronic probes and accept depth attachments
- The auxiliary scribe is a circular carbide scribe – cuts sharp, clean lines smoothly – rotatable for wear

255 Vernier Height Gages (.001" Graduation)					
Cat. No.	EDP	Range	Bar Approximate (Width x Thickness)	Base Approximate (Length x Width)	Description
255Z-12	51229	0-12"	15/16" x 7/32"	4-7/16" x 2-9/32"	In Case
255-12	51230				Without Case
255Z-18	51231	0-18"	15/16" x 7/32"	4-7/16" x 2-9/32"	In Case
255-18	51232				Without Case
255M Vernier Height Gages (0.02mm Graduation)					
Cat. No.	EDP	Range	Bar Approximate (Width x Thickness)	Base Approximate (Length x Width)	Description
255MZ-300	56218	0-300mm	24mm x 5.5mm	113mm x 58mm	In Case
255M-300	56219				Without Case
255EM Vernier Height Gages (.001"/0.02mm Graduation)					
Cat. No.	EDP	Range	Bar Approximate (Width x Thickness)	Base Approximate (Length x Width)	Description
255EMZ-18	65160	0-18"/450mm	15/16" x 7/32"	4-7/16" x 2-9/32"	In Case
255EM-18	65161		(24mm x 5.5mm)	(113mm x 58mm)	Without Case
Accessories for 255, 255M and 255EM Vernier Height Gages					
Part No.	EDP	Description			
PT13791	71460	Straight Scriber			
PT27710	67187	Carbide Scriber (3/16" x 25/64" x 2-3/4")			
PT08962A	51233	Depth Gage Attachment			

Furnished with Straight Scriber.

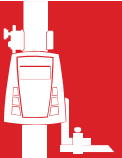
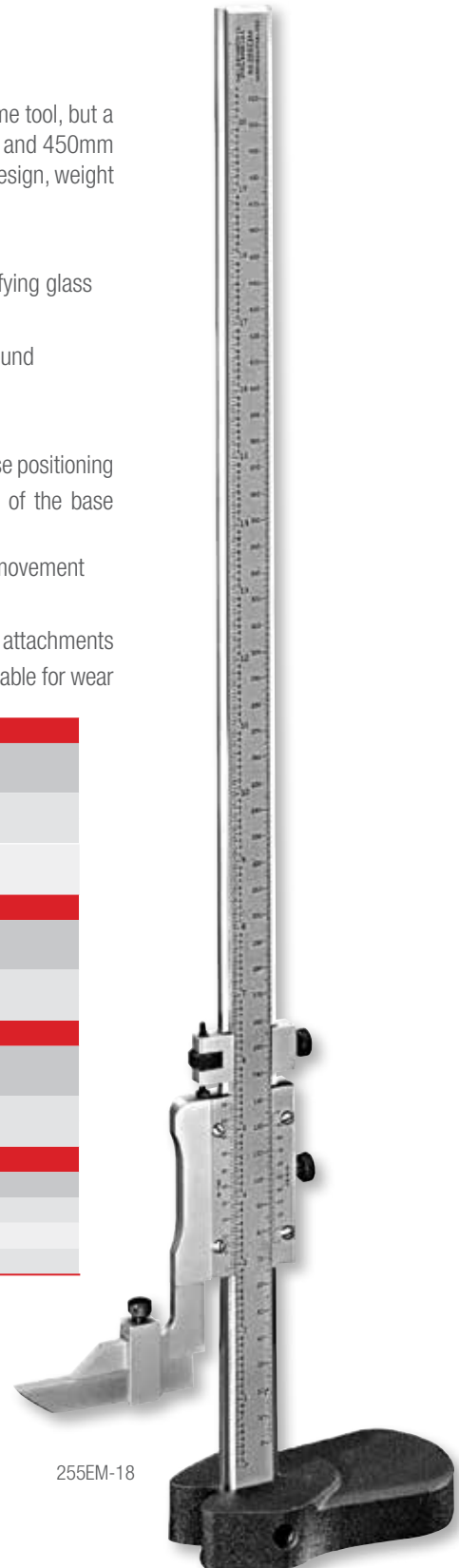

DIAL HEIGHT GAGES

3250 DIAL HEIGHT GAGES

0-6"/0-150MM

The compact 3250 Dial Height Gage is a very useful tool for machinists and inspectors. Applications include scribing lines for layout, height measurement (with or without dial test indicator), and depth measurement (with optional attachment). It is simple to use, reliable, accurate, and fits into most toolboxes.

3250 Height Gages				
Cat. No.	EDP	Range	Dial Grads	Description
3250Z-6	69865	0-6"	.001"	Dial Height Gage, English
3250MZ-150	69861	0-150mm	0.20mm	Dial Height Gage, Metric
PT08680A	51383			Depth Attachment

FEATURES & SPECIFICATIONS

- Sharp, clear dial graduations of .001" or 2mm in one revolution
- Sharp, black graduations on the satin chrome finish bar every .100" or 1mm
- Fine adjustment thumb roll for precision measurements
- Vertical bar set back from the edge for better stability
- Hardened, ground, and lapped base with finger grooves for control and ease of movement
- Base clearance allows the gage to measure full gage range of 0 - 6" or 150mm
- Dial lock screw
- Lock to hold the slide in position
- The auxiliary scribe has a rounded nose for cutting clean, sharp lines with smoothness and less pressure
- Hardened, stainless steel bar, rack, gears, scribe, and scribe carrier
- Positive spring-loaded double pinion anti-backlash control
- Includes metal case



3250-6



3250-6 in case

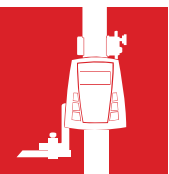

DIGI-CHEK™ HEIGHT GAGES

DHG DIGI-CHEK™ II HEIGHT MASTER

RANGES UP TO 85" AND 2150MM

These are the world's fastest and most precise height masters, ideal for those who need the highest degree of accuracy over an extremely long vertical range.

DIGI-CHEK II Height Master (1-85" Range)		
Cat. No.	EDP	Capacity
DHG 25.	93265	1-25"
DHG 37.	93266	1-37"
DHG 49.	93267	1-49"
DHG 61.	93268	1-61"
DHG 73.*	93269	1-73"
DHG 85.*	93270	1-85"

DIGI-CHEK II Height Master (25-2150mm Range)		
Cat. No.	EDP	Capacity
DHG 625.	93271	25-625mm
DHG 1025.	93272	25-1025mm
DHG 1225.	93273	25-1225mm
DHG 1550.	93274	25-1550mm
DHG 1800.*	93640	25-1800mm
DHG 2150.*	93275	25-2150mm

* Setup charge extra depending on location.

Optional Equipment for DIGI-CHEK II Height Master		
Cat. No.	EDP	Description
HG 525.60 (Inch)	92579	Reverse Reading Blocks
HG 501.3M (Millimeter)	91486	
HG 525.61 (Inch)	92577	1" or 25mm base blocks for use with reverse reading blocks to set dial bore gages
HG 501.4M (Millimeter)	91487	
CS 9133.	92320	Finished wood case for reverse reading and base block

Specifications for DIGI-CHEK II Height Master		
Description	Inch System	Metric System
Tolerance (Stack)	expressed in μin	expressed in μm
	Maximum: 2.5L + 10 (in inches)	.0025L + .25 (in mm)
	Minimum: -10	- .25
Parallelism: Gage Surfaces to Base and Each Other	15 μin	0.4 μm
Resolution	10 μin or 20 μin	0.5 μm or 1.0 μm
Repeatability of Readout	$\pm 20 \mu\text{in}$	0.5 μm or 1.0 μm
Digital Readout	1/2" high figures	12.5mm
Readout Pedestal Height	38"	970mm
Power Supply	Switchable: 115 V 60 Cycle or 220 V 50 Cycle	
Certificate of Calibration (Extra Cost)	expressed in μin	expressed in μm
Uncertainty of Calibration of Stack	10 + 2.0L (in inches)	.25 + .002L (in mm)
Uncertainty of Calibration of Readout	$\pm 30 \mu\text{in}$	$\pm 0.75 \mu\text{m}$

$\mu = .000001 \times \text{unit of measure}$

The accuracy of the surface that supports the gage must be taken into account when determining the accuracy of any measurements.

- Can be used in the laboratory or on the shop floor
- Lower inspection costs by saving time – within 10 seconds the tool can be set into position
- The gage block stack is free-standing, so it will adapt to temperature differences in a reasonable time period
- 1" or 25mm range of adjustment
- Reverse reading block allows readings from the underside of the master gage blocks
- The large, remote digital readout can be placed in the most convenient location and adjusted for best readability
- The housing is heavy and extremely stable with hardened and lapped three-point bearings
- Standard equipment: pedestal stand for readout unit, DIGI-CHEK II plastic dust cover and wood shipping/storage case



SIMPLE, TWO STEP OPERATION IN LESS THAN 10 SECONDS.

1. Set rapid positioner (A) to within .005" (0.15mm) (3 seconds).
2. Final setting (5 seconds).



NEW!

DIGI-CHEK™ HEIGHT GAGES

258, 258M DIGI-CHEK™ HEIGHT GAGES

.100"-24.100"/2-602MM

These gages combine the accuracy of Starrett-Webber Gage Blocks with a precision micrometer head and digital readout.

258 DIGI-CHEK Height Gages (.100"-24.100" Range)						
Cat. No.	EDP	Range	Graduation			
			Scales	Digital Readout	Micrometer Head	Gage Accuracy
DHG12-258	93005	.100"-12.100"	Inches	.001"	.0001"	±.0002"
DHG18-258	93006	.100"-18.100"		.001"	.0001"	±.0002"
DHG24-258	93357	.100"-24.100"		.001"	.0001"	±.0002"
258M DIGI-CHEK Height Gages (2-602mm Range)						
Cat. No.	EDP	Range	Graduation			
			Scales	Digital Readout	Micrometer Head	Gage Accuracy
DHG300-258	93007	2mm-302mm	Millimeters	0.01mm	0.002mm	±.005mm
DHG450-258	93008	2mm-452mm		0.01mm	0.002mm	±.005mm
DHG600-258	93358	2mm-602mm		0.01mm	0.002mm	±.005mm

Finished wood case for 12" (300mm) and 18" (450mm) also available, at additional cost. These finished wood cases are NOT suitable for shipping. Use suggested shipping materials. Certificate of Calibration available at additional cost. Questions and repair regarding Digi-Chek gages should be referred to the Starrett-Webber Division, Tel.: 440-835-0001. The accuracy of the surface that supports the gage must be taken into account when determining the accuracy of any measurements.

READABILITY FEATURES

- Satin chrome scales mounted beside the gage block column for quick reference to the nearest 1" or 25mm reading
- Digital readout reads in .001" or 0.01mm and has a range of 1" or 25mm
- Reads directly from the micrometer head to .0001" or 0.002mm. The micrometer head (our 469) has black figures on the satin chrome thimble. The graduations are staggered for easy counting.
- Both the micrometer head and digital readout are mounted on top of the gage, directly in line with the operator's vision

EASE-OF-HANDLING FEATURES

- The micrometer head has a speeder knob for rapid positioning
- Both over and under heights can be checked directly from the gage blocks in a single setting. Because reference surfaces are provided on the top and bottom of each block, adjacent blocks are in the exact same plane. This eliminates the need to add or subtract block thickness.
- Readings can also be taken from either left, center, or right of the gage block column
- Parts can be checked from .100" or 2mm in height
- The gage block column design permits wringing a 1" block between two blocks in the column. This is convenient for setting and checking other gages such as inside micrometers, end measuring rods, dial bore gages, etc.

ACCURACY AND LONG-LIFE FEATURES

- Gage is housed in a heavily flanged frame for stability and the base has three-point hardened, ground, and lapped bearing pads, making it virtually tip-proof. Gage blocks are assembled in a free-standing system that allows the blocks to conform to temperature variations independently of the frame, thereby reading the same as the workpiece.
- The highly accurate micrometer spindle is one piece, with hardened and stabilized measuring threads
- A 10" riser block is available for increased height capacity

HEIGHT GAGES

DGH12-258 with digital display



DGH12-258 with analog display

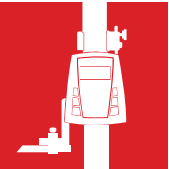

HEIGHT GAGE ACCESSORIES

DEPTH GAGE ATTACHMENTS FOR HEIGHT GAGES

These attachments replace standard scribes and measure the depths of holes and slots, recesses; inside of jigs, fixtures; and over high projections.

They have adjustable rods which are held in the desired position by a knurled binding nut. The ends have a slight radius for point contact on the work.

Right: PT08680A
Middle: PT08962A
Left: PT05409A



Depth Gage Attachments for Height Gages			
Part No.	EDP	Rod Length	Fits Starrett Height Gage No./Size
PT08962A	51233	6" (150mm)	255 8", 12", 18", 300mm, 450mm
PT05409A	51227	8" (200mm)	254 12", 18", 24", 300mm, 450mm, 600mm and all Metric and English 259, 180 and 240, 3752 120 (300mm) and 240 (600mm), 755 240 (600mm)
PT08680A	51383	6" (150mm)	751

HEIGHT GAGES

258RRB, 258RRBM REVERSE READING BLOCKS FOR 258 DIGI-CHEK™ HEIGHT GAGE

Used on 258 DIGI-CHEK™ Height Gages for the precise calibration of working gages and for setting dial bore gages. The block fits in alternate inch positions, its tongue entering the odd numbers and its groove entering the even numbers of the gage block stack.

258RRB and 258RRBM Reverse Reading Blocks		
Cat. No.	EDP	Description
HG 258.RRB	92433	Fits 12", 18" and 24" Gages
HG 258.RRBM	92434	Fits 300mm, 450mm and 600mm Gages

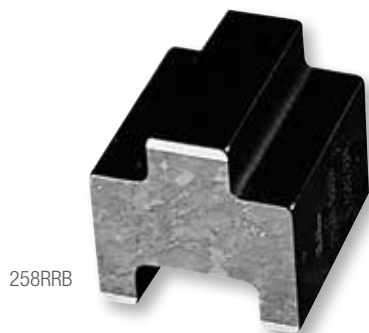

258RRB

258R, 258MR RISER BLOCKS FOR 258 DIGI-CHEK™ HEIGHT GAGE

Increases the range of Inch reading 258 DIGI-CHEK™ Height Gages by 10" and metric reading 258 DIGI-CHEKS™ by 250mm. Heavily flanged for rigidity and stability. Both top and base have three ground and lapped pads to match the pads on the DIGI-CHEK™ base. Retaining plate prevents the DIGI-CHEK™ from being pushed or sliding off the pads. Attractive black wrinkle finish. If desired, riser blocks can be stacked one on top of another.

258R Riser Blocks (10" Blocks)			
Cat. No.	EDP	Accuracy	For:
HG 258.R	99865	±.000040"	12" Gage
HG 258.RA	99866		18" Gage
258MR Riser Blocks (250mm Blocks)			
Cat. No.	EDP	Accuracy	For:
HG 258.MR	99867	±0.001mm	300mm Gage
HG 258.MRA	99868		450mm Gage



258R



HEIGHT GAGE ACCESSORIES

252 HEIGHT TRANSFER GAGES

0-48" / 0-1200MM

The 252 Height Transfer Gage is ideal for use with test indicators or electronic amplifiers to accurately transfer height settings from gage blocks, height gages and other standards.

252 Height Transfer Gages					
Cat. No.	EDP	Range	Fine Adjustment (Approximate)	Base Size - L x W (Approximate)	Gage Rod Dimension
252Z-14	55890	0-14" (350mm)	3/8" (9.5mm)	5-3/4" x 3-1/2" (145 x 90mm)	9" L x .375" Dia. (225 x 9.5mm) with steps
252Z-24	51216	0-24" (600mm)		7-1/2" x 4-1/2" (190 x 115mm)	
252Z-48	51217	0-48" (1200mm)		9" x 6" (225 x 150mm)	

Larger sizes available on special order.
Starrett 708, 709, 711, 650 Test Indicators; 25, 81, 196, 655, 656 Dial Indicators and supplementary attachments also available.
Gage furnished with 9" (225mm) Rod and PT06784-A Gage Holding Rod in wood case.

ACCURACY AND LONG-LIFE FEATURES

- Extreme rigidity provides the vibration-proof stability necessary to permit precise repeat readings with indicators of the highest amplification
- Extremely rigid, rectangular box-type hollow column mounted integrally on a heavy base
- Adjusting mechanism is located in the base so the column and indicator are isolated and not affected by external factors, such as heat or hand pressure

EASE-OF-OPERATION FEATURES

- Hand-fitting base design for sure-grip handling and easy movement
- Bottom of the base has three ground and lapped pads for stability and smooth movement on the surface plate
- Adjustable slide, incorporating a snug for holding test indicators or electronic gage heads, has rapid vertical manual adjustment
- Thumb screw allows slide to be locked
- Knob on base allows fine vertical adjustment of the slide unit relative to the fixed column. This permits the slide with its test indicator to be quickly and precisely adjusted to the desired setting.

TOOL AND GAGING HOLDERS

- A snug on the slide provides two holes (.375" [9.5mm] and .156" [4mm]) for holding gage rods or scribers. A 9" (225mm) rod furnished with the gage is especially useful for reaching confined areas or reaching heights greater than the range of the gage.
- The rod has a major diameter of .375" (9.5mm) and stepped diameters of 1/4" (3.2mm) and 7/32" (5.5mm) at one end and 5/16" (8mm) at the opposite end
- 708 and 709 Test Indicators can be mounted on this rod using PT22428 swivel clamp. 196 Universal Back-Plunger Indicators can be mounted using Starrett snugs, Part PT18718 or PT18724 (snugs not furnished).
- PT06784-A Gage Holding Rod is included to accommodate the 715-1 Gaging Head when the Transfer Gage is used with the 717 Electronic Gage. A wire retaining clip keeps electronic gage head cables from deflecting the gage-holding rod.
- 25, 81, 655 and 656 Dial Indicators also can be used on the height gage by means of a PT06784-A Gage Rod (furnished)
- Other useful attachments (extra) are surface gage spindles (57C or 57D, 12" [300mm]) and 18" [450mm] – which are extremely useful for scribing and layout



Pictured with 717 Gage Amplifier and 715-12 lever probe.

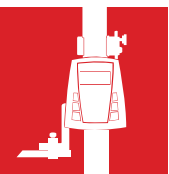

HEIGHT GAGE ACCESSORIES

STRAIGHT SCRIBERS FOR STARRETT HEIGHT GAGES*

All steel scribers are hardened to approximately HRC 62 and have a rounded tip which cuts sharp, clear lines smoothly, with less pressure, on any material.



Straight Scribers for Starrett Height Gages				
Part No.	EDP	Point	Size	Fits Starrett Height Gage No./Size
PT14343	71511		1/4 x 1/2 x 3" (6.4 x 12.7 x 75mm)	254 12", 18", 24", 300mm, 450mm, 600mm
PT13816	52367	Hardened Tool Steel	1/4 x 1/2 x 6" (6.4 x 12.7 x 150mm)	254 Metric and English
PT13817	52368		1/4 x 1/2 x 10" (6.4 x 12.7 x 250mm)	259 18" and 24"
PT16566	72288	Hardened Tool Steel	5/8 x 3/8 x 3-5/8"	254 36", 48", 60", 72", 900mm
PT13791	71460	Hardened Tool Steel	3/16 x 25/64 x 2-3/4" (4.8 x 10 x 69.9mm)	255 8", 12", 18", 300mm, 450mm
PT22357	12295	Carbide	1/4 x 7/16 x 3" (6.4 x 11.1 x 75mm)	3752

CIRCULAR CARBIDE SCRIBERS*

This circular scriber cuts a sharper, cleaner line with less pressure than any other scriber. It resists breakage and chipping but can be rotated for wear.

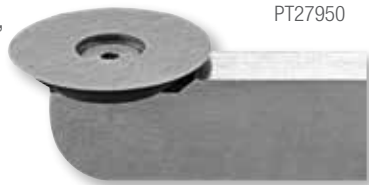

PT27950

Circular Carbide Scribers				
Part No.	EDP	Point	Size	Fits Starrett Height Gage No./Size
PT27724	67185	Circular Carbide	1/4 x 1/2 x 3" (6.4 x 12.7 x 75mm)	254 12", 18", 24", 300mm, 450mm, 600mm
PT27708	67186		1/4 x 1/2 x 6" (6.4 x 12.7 x 150mm)	254 Metric and English 259 18", 24"
PT27710	67187	Circular Carbide	3/16 x 25/64 x 2-3/4" (4.8 x 10 x 69.9mm)	255 8", 12", 18", 300mm, 450mm
PT27950	67015	Circular Carbide	1/4" (6.4mm) Diameter Shank	2000, 2001 Altissimo
PT28131	67007	Circular Carbide	1/4 x 7/16 x 3" (6.4 x 11.1 x 75mm)	3752, 752

3259-AC DIGITAL HEIGHT GAGE SCRIBER CARRIER HOLDER

Scriber carrier for use with 3259 Height Gages to allow attachment of standard quarter inch by half inch tall accessories.



3259-AC

3259-AC Digital Height Gage Scriber Carrier Holder		
Cat. No.	EDP	Description
3259-AC	69859	Digital height gage scriber carrier holder

STEM-MOUNT INDICATOR ATTACHMENT FOR HEIGHT GAGES

This attachment replaces the standard scriber and provides a way to mount dial indicators or LVTD style probes having 3/8" diameter shafts onto your height gage. By using the lower stem of the indicator as an attachment point, the indicator can be used to guarantee the amount of down pressure on the part is the same as the original set zero position.



PT99441

Stem-Mount Indicator Attachment for Height Gages

Part No.	EDP	Description
PT99441	52991	Stem-mount indicator attachment

INDICATOR ATTACHMENT

DOVETAIL STYLE

Replaces standard scriber. Provides means to attach dovetail equipped test indicators or electronic probes to height gages. Allows indicator to be used to ensure the down pressure on the part is the same as the original set zero position.



PT99454

Dovetail Style Indicator Attachment

Part No.	EDP	Description
PT99454	68713	Indicator attachment, dovetail style

*Starrett Originals





PRECISION MAKES THE DIFFERENCE

PURE PRECISION.

Introducing the HDV300 Video-based measurement system. The power of an optical comparator, meets the precision of digital video.



Starrett®

(978) 249-3551 • starrett.com

Follow us!

