



DEPTH GAGES

DEPTH GAGES

5004 ELECTRONIC DEPTH GAGES

0-24"/0-600MM

- Ideal for large part measurement up to 24" (600mm)
- Three movable bridge attachments provide additional large part measurement capacity

5004 Electronic Depth Gages

Cat. No.	EDP	Range/Size	Description
5004BZ-12/300	14583	0-12" (0-300mm)	Electronic depth gage
5004BZ-16/400	14584	0-16" (0-400mm)	Electronic depth gage
5004BZ-20/500	14585	0-20" (0-500mm)	Electronic depth gage
5004BZ-24/600	14586	0-24" (0-600mm)	Electronic depth gage
5004BZ-32/800	14587	0-32" (0-800mm)	Electronic depth gage

Accessories for 5004 Depth Gages

Part No.	EDP	Range/Size	Description
PT06133	12825	16" (400mm)	Movable bridge attachment for use with 5004 Depth Gages
PT06134	12826	20" (500mm)	Movable bridge attachment for use with 5004 Depth Gages
PT06135	12827	24" (600mm)	Movable bridge attachment for use with 5004 Depth Gages
PT06136	12828	1.024" (26mm) overall length	Offset attachment for use with 5004 Depth Gages

Smart Cables for 5004 Depth Gages

Cat. No.	EDP	Description
798SCKB	69889	USB cable to PC (In focused window)
798SCU	73321	SmartCable USB for 798, 5004B
798SCM	69894	Connect to 7612, 7613 Gage Mux

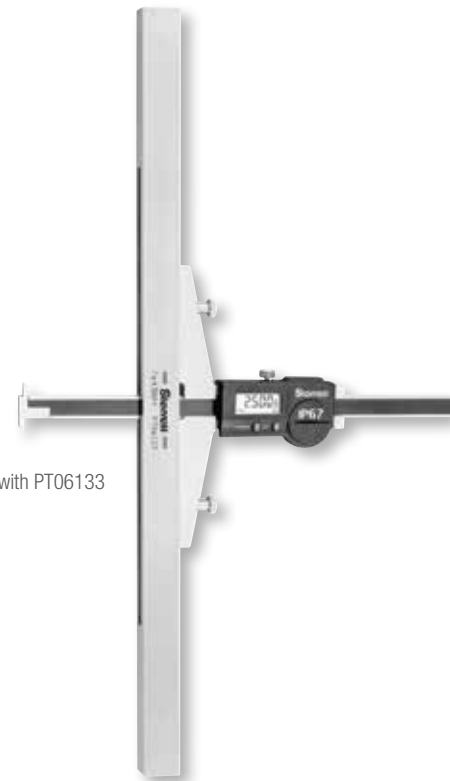
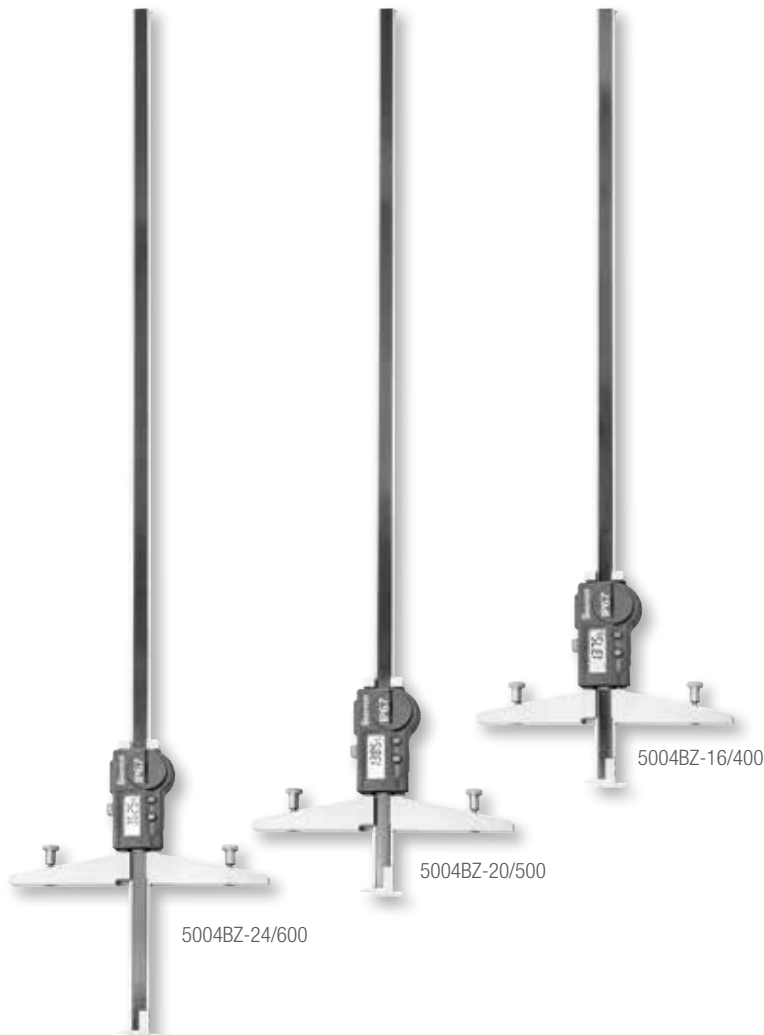

5004BZ with PT06133

FEATURES AND SPECIFICATIONS



- Hardened stainless steel construction
- Coolant resistant
- Mode and Set buttons control a wide range of functions: On/Off, Absolute/Relative display, Inch/Metric display, Preset and Hold
- RS232 data transmission port
- Furnished with one CR2032 lithium battery that will provide over a year of life with normal use
- Protective wooden case
- Resolution: 0.0005"/0.01mm
- Includes offset attachment PT06136
- IP67 protection

IP PROTECTION



An IP number is composed of two numbers, the first referring to protection against solid objects and the second against liquids.

First number 6: Totally protected against dust

Second number 7: Protection against submersion in water under standardized conditions of pressure for 30 minutes



DEPTH GAGES

3753A ELECTRONIC DEPTH GAGES

0-12"/0-300MM

The 3753 is light and easy to use for depth measurements within its range.

READABILITY FEATURES

- Clear, easily-read numbers, properly sized for the tool

DESIGN FEATURES FOR ACCURACY AND LONG LIFE

- Linear accuracy: $\pm .001"$ ($\pm 0.03\text{mm}$)
- Resolution: $.0005"$ (0.01mm)
- Exclusive Starrett-designed microprocessor chip
- Hardened stainless steel body and slide for long life
- Fine adjustment thumb roll for precision measurements
- Lock to hold the slide in position
- Hardened base is 3-15/16" (99mm) long, but optional base extensions of 7" and 12" (175 and 300mm) are available. Spacing between holes is 2-3/4" (70mm).
- A hook attachment is furnished with the gage, making it possible to take readings from the edge of a workpiece to edges of slots, grooves, shoulders, and other I.D. length dimensioning. The removable hook has the screw permanently attached to prevent loss.
- One-year minimum battery life with furnished 3-volt battery, CR2032

ACTION FEATURES WITH THREE CONTROL BUTTONS

- Inch/millimeter conversion
- Zero at any position
- Manual ON/OFF plus a built in automatic OFF after 15 minutes of nonuse



3753 with 180 extension



3753 shown with optional 3648-180 base extension attachment

DEPTH GAGES

3753A Electronic Depth Gages		
Cat. No.	EDP	Description
3753A-6/150	12258	0-6"/150mm Range, Depth Gauge in Case
3753A-8/200	12259	0-8"/200mm Range, Depth Gauge in Case
3753A-12/300	12260	0-12"/300mm Range, Depth Gauge in Case

Accessories for 3753A Electronic Depth Gages		
Cat. No.	EDP	Description
3648-180	12261	180mm Base Extension
3648-260	12262	260mm Base Extension
3648-320	12263	320mm Base Extension
PT99492	65650	Two 3-Volt Batteries, CR2032



DEPTH GAGES

3753B ELECTRONIC DEPTH GAGES

0-12"/0-300MM

The 3753B Electronic Depth Gauge is a versatile, easy-to-use tool for measuring depth, slot width, small sections and other applications.

3753B Electronic Depth Gages		
Cat. No.	EDP	Description
3753B-6/150	12690	0-6"/150mm Range, Depth Gauge in Case
3753B-8/200	12692	0-8"/200mm Range, Depth Gauge in Case
3753B-12/300	12694	0-12"/300mm Range, Depth Gauge in Case
Accessories for 3753B Electronic Depth Gages		
Cat. No.	EDP	Description
3648-180	12261	180mm Base Extension
3648-260	12262	260mm Base Extension
3648-320	12263	320mm Base Extension
PT63388	72517	Computer Interface Cable to PC (USB)
PT99492	65650	Two 3-Volt Batteries, CR2032
798SCKB	69889	USB cable to PC (In focused window)
798SCU	73321	SmartCable USB for 798, 5004B
798SCM	69894	To 7612 or 7613

FEATURES AND SPECIFICATIONS



- Hardened, stainless steel bar for long life
- Removable hook attachment for measurements from the edge of a work piece to the inside or outside edge of slots, grooves, etc.
- Lock to hold the slide in position
- Fine adjustment thumb roll for precision measurements
- Large, easy to read LCD, .310" character height
- IP67 level of protection against coolant, water, dirt and dust
- Induction type linear encoder system
- Patented non-contact RS-232 data output
- CR2032 3-volt battery (>1 year batter life under normal use)
- Inch/mm conversion
- Zero at any position
- Automatic off after 30 minutes of nonuse without loss of position upon reactivation
- Linear Accuracy: $\pm .001"$ (0.03mm)
- Resolution: $.0005"$ (0.010mm)



3753B-6/150



3753B-12/300

IP PROTECTION

An IP number is composed of two numbers, the first referring to protection against solid objects and the second against liquids.

First number 6: Totally protected against dust

Second number 7: Protection against submersion in water under standardized conditions of pressure for 30 minutes



DEPTH GAGES

450, 450M DIAL DEPTH GAGES

0-12"/0-300MM

These depth gages are ideal for the individual mechanic. They are light, reliable and accurate for measurements to .001" or 0.02mm and will fit into most toolboxes.

450 Dial Depth Gages (.001" Graduation)			
Cat. No.	EDP	Range	Description
450-6	56766	0-6"	6" Gage without Case
450-12	56768	0-12"	12" Gage without Case
450M Dial Depth Gages (0.02mm Graduation)			
Cat. No.	EDP	Range	Description
450M-300	64276	0-300mm	300mm Gage without Case
Accessories for 450 and 450M Dial Depth Gages			
Cat. No.	EDP	Description	
PT22287	65861	7"/175mm Base Extension	
PT22288	65862	12"/300mm Base Extension	
450ZZ-6	56776	6" Case Only	
450ZZ-12	56777	12" Case Only	

READABILITY FEATURES

- Sharp, easy-to-read dial graduations of .001-.100" or 0.02-2mm in one revolution
- Sharp, black graduations on the satin chrome finished bar, every .100" or 1mm

EASE-OF-HANDLING AND VERSATILITY FEATURES

- Lock screw for dial bezel
- Lock screw for holding the measuring rod in position
- Optional base extensions of 7" and 12" (175 and 300mm) are available to increase the base span on both models
- Removable hook attachment permits readings from the edge of a workpiece to edges of slots, shoulders, etc.

ACCURACY AND LONG-LIFE FEATURES

- Hardened, stainless steel base, measuring bar, rack and gears
- Positive split gear anti-backlash control



Left: 6" model
Below: 12"/300mm base extension



DEPTH GAGES

448, 448ME VERNIER DEPTH GAGES

0-12"/0-300MM

These are easy-to-use, very accurate depth gages. They are designed for measuring the depths of holes, slots, and recesses and for inspecting jig, fixtures and die work. They are also ideal for measuring from a plane surface to toolmakers' buttons for locating center distances. Readings are in .001" and 0.02mm.

- Heads are hardened, ground and lapped
- Measuring blades are hardened and ground and have accurate and sharp machine divided graduations
- All English graduations read to .001", with the bar being graduated in .025" increments
- All metric graduations read to 0.02mm, with the bar being graduated in 0.5mm increments
- Screw type adjusting nut allows for fine measuring adjustment
- Slide lock nut to hold measurement position
- Vernier plates are adjustable

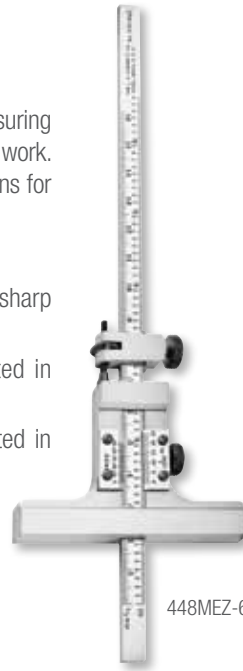

448MEZ-6

Inch Reading/Graduation – .001"

Cat. No.	EDP	Range	Blades Furnished	Base Length x Width
448Z-6	52306	0-6"	One (6")	
448Z-12	52308	0-12"	One (12")	2-3/4 x 1/4"
448Z-612	52310	0-12"	Two (6" and 12")	

Inch and Millimeter Reading/Graduation – .001" and 0.02mm – Both Edges

Cat. No.	EDP	Range	Blades Furnished	Base Length x Width
448MEZ-6	52312	0-6" (150mm)	One (6"/150mm)	
448MEZ-12	52314	0-12" (300mm)	One (12"/300mm)	2-3/4 x 1/4" (70 x 6.35mm)
448MEZ-612	52316	0-12" (300mm)	Two (6"/150mm and 12"/300mm)	

237, 237M STEEL RULE DEPTH GAGES

0-6"/0-150MM

These very handy depth gages can be used to quickly obtain measurements in 64th of an inch or 1/2mm by simply adjusting the rule to the required depth.

- The gage consists of a nicely finished, hardened steel head and an accurate, machine divided, tempered steel rule. These rules are either our 610N (6") or our 635N (150mm) models.
- Gage can be smoothly adjusted to the required measurement and then locked into position by a knurled nut
- Base is cut out on one side, adjacent to the rule, permitting easier readings and more accurate measurements
- 6" hook rule (236HC, EDP 51077) also available, permitting easier readings from the edge of a workpiece to the edges of slots, shoulders, etc. Graduated in 32nds, 64ths.

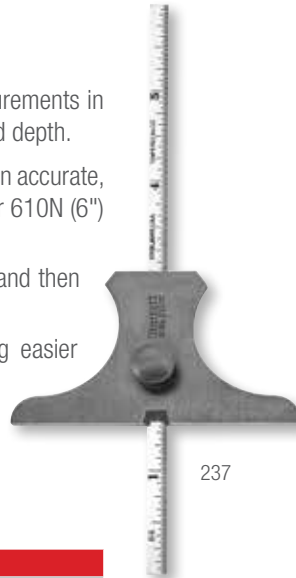

237

237 Steel Rule Depth Gages (0-6" Range)

Cat. No.	EDP	Graduation	Head Length x Width
237	51080	32nds, 64ths	2-5/8 x 1/8"

237M Steel Rule Depth Gages (0-150mm Range)

Cat. No.	EDP	Graduation	Head Length x Width
237M	51081	mm, 1/2mm	66 x 3mm

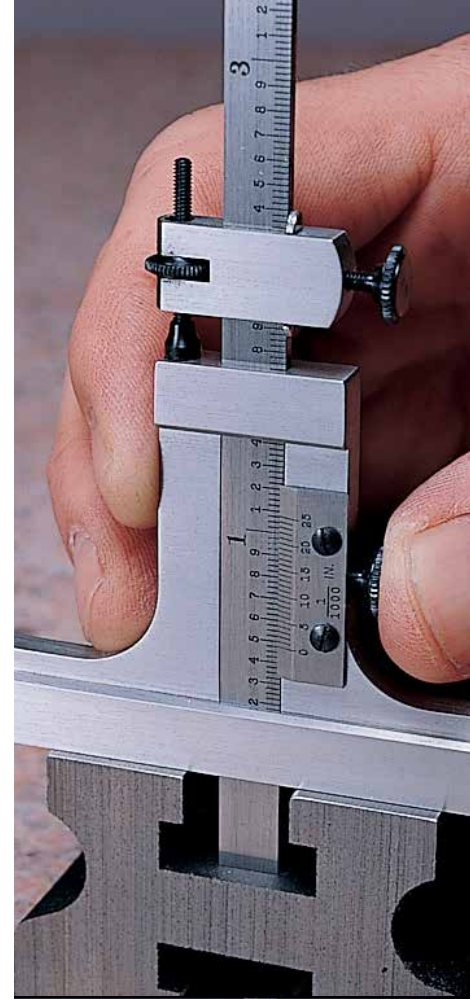

DEPTH GAGES

236, 236H COMBINATION STEEL RULE DEPTH AND ANGLE GAGES

0-6"

236

This depth gage has an added feature permitting its use as a protractor for measuring angles. It is a simple, handy tool that is a welcome addition to any machinist's toolbox.

- The head is graduated both left and right to 30, 45, and 60 degrees. The rule can be set to any of these angles by swinging the rule until the line on the turret coincides with the desired angle.
- Head is made of hardened steel, ground, and nicely polished – 2-5/8" (66mm) long and 1/8" (3mm) wide
- One side of the base is cut out to permit easier and more accurate readings
- The center of the head is recessed so that the tool will lay flat to permit more accurate measurements
- Tempered rule has been accurately machined divided, is smoothly fitted to the head, and can be locked in position by a knurled nut.

236H

These versatile gages can be used for calipering, as a depth gage by simply reversing the rule, as a protractor, and as a hook rule when removed from the tool.

Features are the same as the 236 except that a hook rule and an extra 6" (150mm) long rod are furnished with this gage. The rod has a 5/64" (2mm) diameter so it can measure the depth of small holes, slots, and recesses that the rule will not enter.

236 and 236H Combination Steel Rule Depth and Angle Gages (0-6" Range)				
Cat. No.	EDP	Graduation	Angle Degrees	Description
236	51074			6" Combination Gage
236HA	51075	32nds, 64ths	30, 45, 60	6" Combination Gage with Hook Rule
236HB	51076			6" Combination Gage with Hook Rule and Rod
236HC	51077	32nds, 64ths	None	6" Hook Rule Only*
236HD	51078	None	None	6" Rod Only

Also available on request with C610N-6 satin chrome rule.
 * Hook rule only for 236, 236H, 237, 493 and 493B.

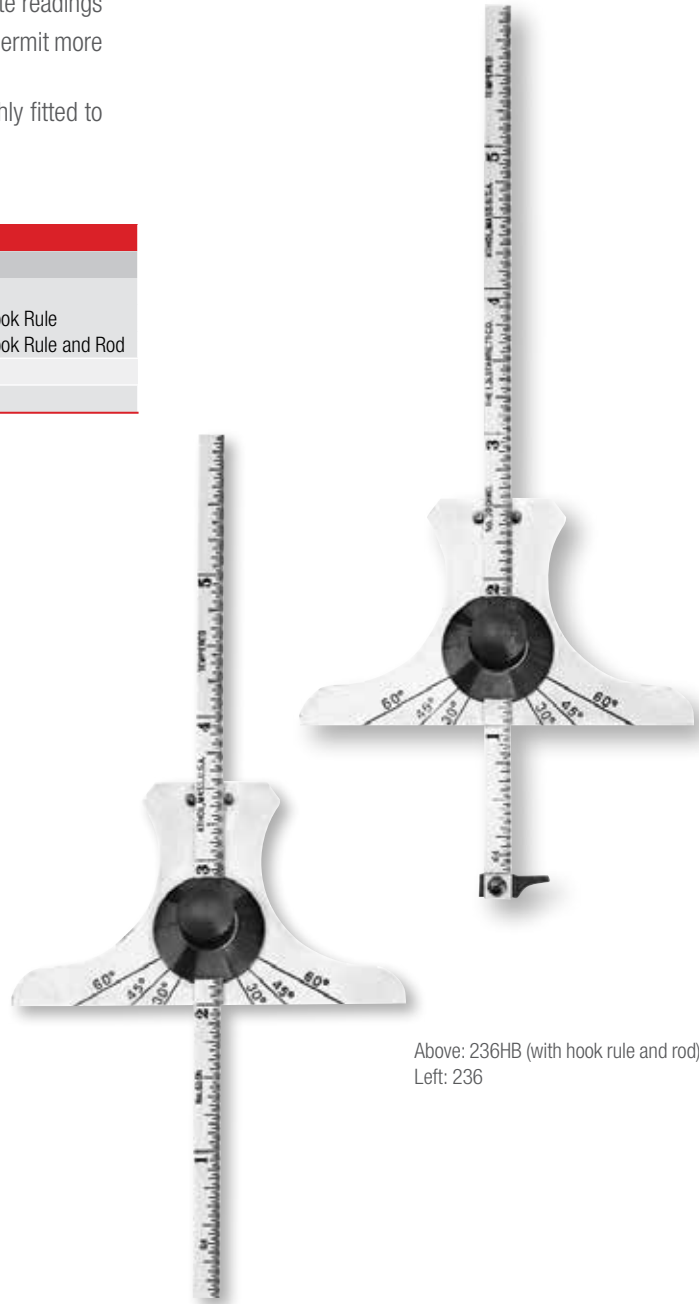

Above: 236HB (with hook rule and rod)
 Left: 236



DEPTH GAGES

DIAL DEPTH GAGES

These depth gages are direct reading tools, referencing from their hardened and ground bases. All bases are 2-1/2" (64mm) long. They are quicker and more convenient to use than any other type of depth gage within their ranges and accuracy. Electronic Indicators can be furnished by special order.

640, 640M DIAL DEPTH GAGES

0-1/2"/0-10MM

640 DIAL DEPTH GAGES

The contact is slightly up into the base at rest. In action, the inspector sets the contact at zero, which is usually at the bottom of the base. Then the top button is pushed down to contact the work and the measurement is taken.

640R DIAL DEPTH GAGES

These gages are the same as the 640 except they have reverse movement (no push button) and can easily be used with one hand. Simply set on zero and apply the contact to the work and read the measurement.



640

640 Dial Depth Gages

640 Dial Depth Gages				
In Case				
Cat. No.	EDP	Range	Graduation	Dial Reading
640JZ	52705	0-1/2"	.0005"	0-50
640RJZ	52709			
640MJZ	55997	0-10mm	0.01mm	0-100
640MRJZ	56001			

643 DIAL DEPTH GAGE

0-.125"

This gage has a knife-edge base and a needle point contact which has been hardened and ground. The knife-edge base has a cutout so the conical point can be precisely positioned for close work. Point is 1/2" (12.7mm) long with a 40° included angle.

In action, the inspector gently pushes against a surface plate or other calibrated surface. If needed, rotate the bezel dial's zero indication with the needle. Zero is then set and can be locked via the locking screw.



643

643 Dial Depth Gages

In Case		Without Case		Range	Graduation	Dial Reading
Cat. No.	EDP	Cat. No.	EDP			
643JZ	52714	643J	52715	0-.125"	.0005"	0-25-0

Electronic version available from Special Order Division.



DEPTH GAGES

644, 644M DIAL DEPTH GAGES

0-3"/0-75MM

These gages are for longer ranges, and are accurate and simple to use. Put the contact on the work to be measured and push the gage head down until the base stops at the reference point and take your reading.

Furnished with three rounded-end contact points to cover the range. Flat end contact points are also available on special order.

The zero setting can be checked with the shortest contact in place by pushing down on a flat surface.

644 Dial Depth Gages						
In Case		Without Case		Range	Graduation	Dial Reading
Cat. No.	EDP	Cat. No.	EDP			
644JZ	52718	644J	52719	0-3"	.001"	0-100
644MJZ	56027	644MJ	56028	0-75mm	0.01mm	0-100



648 DEPTH GAGE BASES

Depth gage base with 25SC38 Stem Collet to fit 3/8" (9.5mm) stem dia. (as per AGD). Split bushings for adapting stem diameter are available but not included.

648 Depth Gage Bases		
Cat. No.	EDP	Base Size
648-4	65850	4" (100mm)
648-6	65851	6" (150mm)
648-8	65852	8" (200mm)

648 Depth Gage Bases will also accommodate the 644 Dial Depth Gage.



DEPTH GAGES

642, 642M TOP READING DIAL DEPTH GAGES

0-8.6"/0-215MM

This dial depth gage uses the back-plunger indicator to provide an upward-facing dial for easier readout. The operator selects the extension and contact point required, zeros the tool on a master and then reads any deviation of the work directly on the dial.

- Indicator does not have to be repositioned to get the full range available
- Choice of 2-1/2" (60mm) or 4" (100mm) base
- Two contacts and five extensions extend the range to 8.6" or 215mm
- Charts are supplied showing combinations of contacts and extensions required to achieve certain lengths



Above: 642AZ side view
Below: top view



642 Top Reading Dial Depth Gages*					
Cat. No.	EDP	Range	Graduation	Dial Indicator Range	Approx. Base Length
642Z	65103	0-8.6"	.001"	.200"	2-1/2"
642AZ	65104	0-8.6"	.001"	.200"	4"
642MZ	65105	0-215mm	0.01mm	5mm	60mm
642MAZ	65106	0-215mm	0.01mm	5mm	100mm

*With maximum extension added and contact options

