

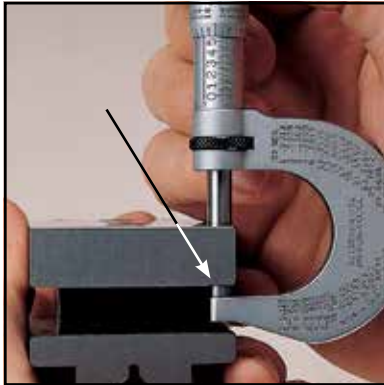

MICROMETERS

STARRETT RELIABLE PRECISION MICROMETER DESIGN AND MANUFACTURING FEATURES

MICROMETERS



Tapered Frame – a Starrett original feature – permits measurements in narrow slots and tight places. Standard with Starrett.

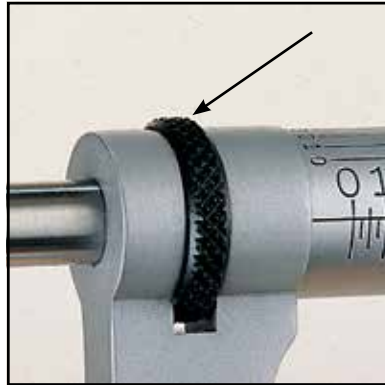

Ring-type lock nut convenient to use. Permits locking of spindle at any reading.

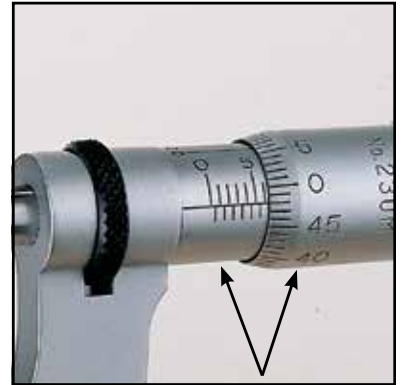

Easy to read with distinct black figures against satin-chrome finish.



Staggered graduations, advanced design, a Starrett original feature. Quick reading figures on inch reading micrometers. Every graduation numbered for quick, positive identification. Easy to read with distinct black figures against satin-chrome finish.



Friction thimble, smooth uniform pressure independent of "feel."



Ratchet stop/speeder for consistent measurements and to speed opening or closing of tool.

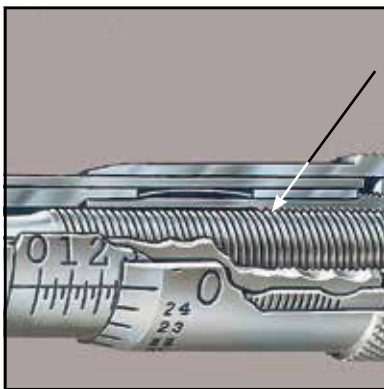

Extra Hard Threads with Extreme Lead Accuracy. Special high carbon steel gives harder threads which are hardened, stabilized, and precision ground from the solid to ensure long and accurate life.

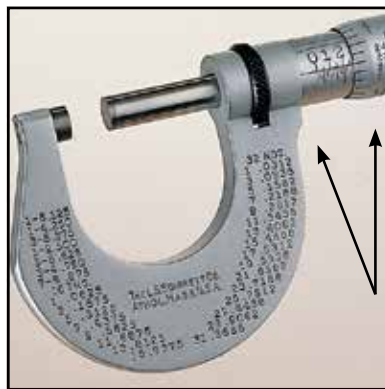

Balanced design; plus no-glare satin chrome finish makes the tool easy to hold and read, as well as resistant to stains, corrosion and wear.

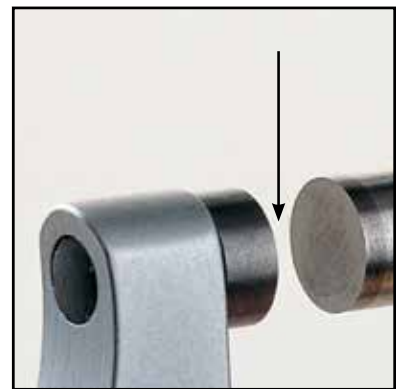

Micro-Lapped "Mirror" Finish on the measuring faces – a Starrett original feature that ensures more accurate measurements. Available with carbide faces or hardened, high-carbon steel faces.

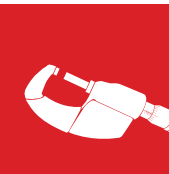

MICROMETER QUALITY AND ACCURACY

Product quality and accuracy cannot be valid unless referenced to a quality and accuracy standard.

All Starrett precision measuring tool standards meet or exceed accuracy and performance specifications of national and international standards and are traceable to the National Institute of Standards and Technology.

The Starrett Company does not rely on statistical sampling inspection. Every precision measuring tool is individually inspected.

All Starrett micrometers have the same accurate heads as outlined in the chart. Inaccuracies because of size can be minimized if the tools are set accurately to standard, and measurements are carried out in a similar position with similar pressure.

HOW TO ADJUST STARRETT MICROMETERS

Adjustments to Starrett Micrometers are rarely needed; however, if it becomes necessary, they can be readily adjusted in two easy operations as follows:



1. If any play should develop in the spindle screw threads due to wear of the spindle nut after long use, first back off the thimble, insert the spanner wrench in the slot of the adjusting nut and tighten just enough to eliminate play. Illustration shows how easily this is done.

2. After carefully cleaning all dirt or grit from the measuring faces of anvil and spindle, bring them together and insert the spanner wrench in the small slot of the sleeve. Then turn the sleeve until the line on the sleeve coincides with the zero line on the thimble as shown.

Starrett Micrometer Accuracy Standards (Unless Otherwise Noted on the Catalog Page)			
Type	Range	Readout	Accuracy
Mechanical	1"	.001"	±.0001"
	1"	.0001"	±.00005"
	25mm	0.01mm	±0.002mm
	25mm	0.001mm	±0.002mm
Electronic	1"	.00005"	±.0001"
	25mm	0.001mm	±0.002mm

KEY TO STARRETT MICROMETER NUMBERING SYSTEM

Key to Starrett Micrometer Numbering System

Prefixes

R	Reverse Reading
S	Micrometer Set
T	.0001" Reading
V	0.001mm or 0.002mm Reading, as specified

Suffixes

F	Friction Thimble
L	Lock Nut
M	Metric
N	Non-Rotating
P	Plain
R	Ratchet Stop
S	Speeder
TN	Threaded Hub and Check Nut
W/SLC	Standard Letter of Certification
X	Micro-lapped Carbide Measuring Faces
Z	With Case
ZZ	Case Only

MEASURING TIPS FROM OUR EXPERIENCE

- Most obvious to everyone is to keep the work to be measured and the micrometer anvil and spindle faces clean.
- For very fine measurements, the micrometer should be set to zero or to a standard by your "feel", by the friction thimble, or by the ratchet, whichever you will be using.
- The most popular micrometer option has been the ratchet speeder because it does three things well: it speeds opening and closing, it applies uniform pressure from the ratchet, and it allows for using the thimble for individual "feel".
- The speeder is helpful because it takes forty turns to cover the range of a typical English-reading tool and fifty turns to cover the range of a metric-reading tool.
- Large micrometers especially should be set to a standard in the same approximate position in which they will be used, that is, vertical or horizontal, to minimize any frame flexure influence.
- Too much speed in approaching the work will result in an inaccurate measurement.
- If the micrometer has been set to a flat standard, you can get approximately .0001" (0.0025mm) difference when measuring over a round because the same pressure is being applied to a point or line contact.
- Carbide or hardened steel measuring faces are a matter of choice. Carbide wears longer but many craftsmen think they get a better "feel" with highly finished steel measuring surfaces.
- Insulating pads on micrometers are a matter of personal preference. With the Starrett balanced micrometer design, there is no need for insulation. Insulation from hand heat is usually more beneficial on long sections, such as end measuring rods.



HOW TO READ A STARRETT MICROMETER

GRADUATED IN THOUSANDTHS OF AN INCH

.001"

The pitch of the screw thread on the spindle is 40 threads per inch. One revolution of the thimble advances the spindle face toward or away from the anvil face precisely 1/40" or .025 inches.

The reading line on the sleeve is divided into 40 equal parts by vertical lines that correspond to the number of threads on the spindle. Therefore, each vertical line designates 1/40" or .025 inches. Lines vary in length for easy reading. Every fourth line, which is longer than the others, designates a hundred thousandth. For example: the line marked "1" represents .100" and the line marked "2" represents .200", etc.

The beveled edge of the thimble is divided into 25 equal parts with each line representing .001" and every line numbered consecutively. Rotating the thimble from one of these lines to the next moves the spindle longitudinally 1/25 of .025", or .001". Rotating two divisions represents .002", etc. Twenty-five divisions indicate a complete revolution of .025" or 1/40 of an inch.

To read the micrometer in thousandths, multiply the number of vertical divisions visible on the sleeve by .025", and to this add the number of thousandths indicated by the line on the thimble which coincides with the reading line on the sleeve.

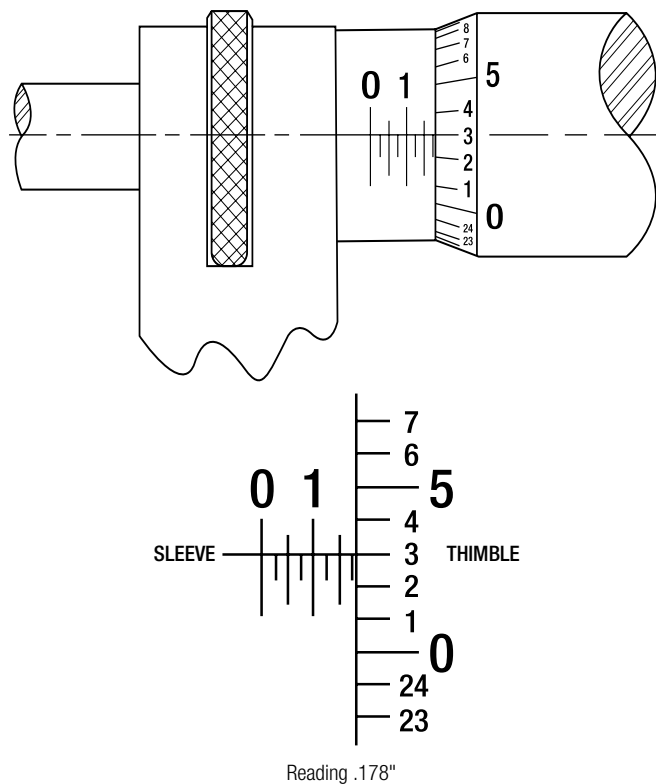

EXAMPLE:

The "1" line on sleeve is visible, representing 100"
 There are 3 additional lines visible, each representing .025"; 3 x .025" = .075
 Line "3" on the thimble coincides with the reading line on the sleeve,
 each line representing .001"; 3 x .001" = .003"
 The micrometer reading is 178"

GRADUATED IN TEN-THOUSANDTHS OF AN INCH

.0001"

Starrett micrometers graduated in ten-thousandths of an inch read like micrometers graduated in thousandths, except that an additional reading in ten-thousandths is obtained from a vernier scale on the sleeve.

The vernier consists of ten divisions on the sleeve, which occupy the same space as nine divisions on the thimble (Fig. B). Therefore, the difference between the width of one of the ten spaces on the vernier and one of the nine spaces on the thimble is one-tenth of a division on the thimble, or one ten-thousandth (.0001").

To read a ten-thousandths micrometer, first obtain the thousandths reading, then see which of the lines on the vernier coincides with a line on the thimble. If it is the line marked "1" on the sleeve, add one ten-thousandth, if it is the line marked "2", add two ten-thousandths, etc.

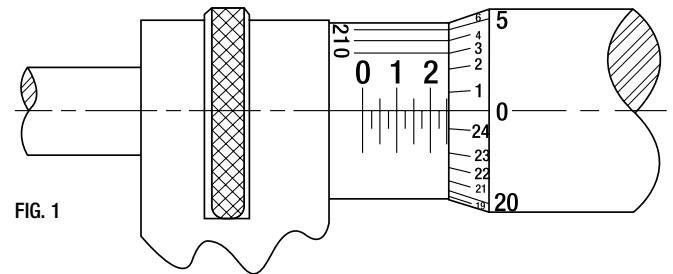

FIG. 1

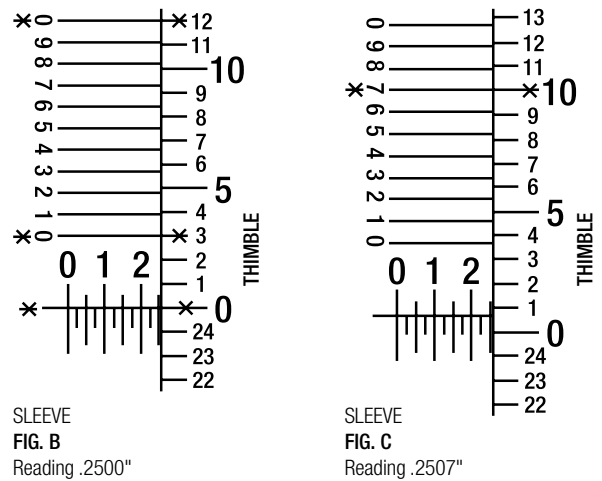

FIGURE C – READING .2507"

The "2" line on sleeve is visible, representing 200"
 There are two additional lines visible, each representing .025" 050"
 The reading line on the sleeve lies between the "0" and "1" on the
 thimble indicating that a vernier reading must be added ---
 The "7" line is the only line on the vernier that coincides with a line on
 the thimble, representing 7 x .0001" = .0007"
 The micrometer reading is 2507"



GRADUATED IN HUNDREDTHS OF A MILLIMETER

0.01MM

The screw head pitch is one-half millimeter (0.5mm). One revolution of the thimble advances the spindle face toward or away from the anvil face precisely 0.5mm.

The reading line on the sleeve is graduated above the line in millimeters (1.0mm) with every fifth millimeter being numbered. Each millimeter is also divided in half (0.5mm) below the reading line. Two revolutions of the thimble to advances the spindle 1.0mm.

The beveled edge of the thimble is divided into fifty equal parts, with each line representing 0.01mm and every fifth line being numbered. Rotating the thimble from one of these lines to the next moves the spindle longitudinally 0.01mm; rotating two divisions represents 0.02mm, etc.

To read the micrometer, add the number of millimeters and half-millimeters visible on the sleeve to the number of hundredths of a millimeter indicated by the thimble graduation indicated by the reading line.

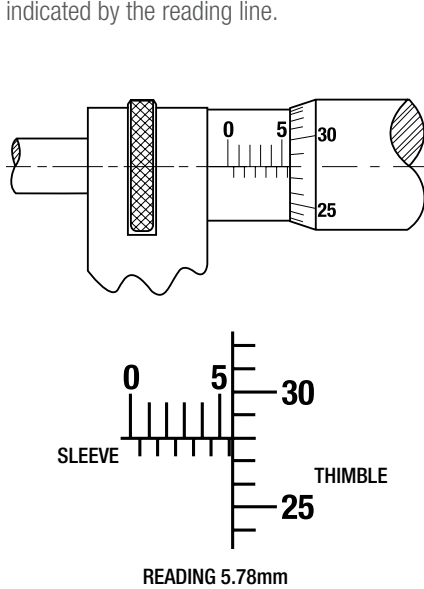

EXAMPLE:

The 5mm sleeve graduation is visible 5.00mm
 One additional 0.5mm line is visible on the sleeve 0.50mm
 Line 28 on the thimble coincides with the reading line on the sleeve, so $28 \times 0.01\text{mm} = 0.28\text{mm}$
 The micrometer reading is 5.78mm

GRADUATED IN TWO-THOUSANDTHS OF A MILLIMETER

0.002MM

Metric vernier micrometers graduated in 0.002mm are used like those graduated in hundredths of a millimeter (0.01mm), except that an additional reading in two-thousandths of a millimeter (0.002mm) is obtained from a vernier scale on the sleeve.

The vernier consists of five divisions on the sleeve, which occupy the same space as nine divisions on the thimble (Fig. B). Therefore, the difference between the width of one of the five spaces on the vernier and one of the nine spaces on the thimble is one-fifth or two-tenths of a division on the thimble, or two-thousandths (0.002mm).

To read a 0.002mm micrometer, first obtain the hundredth of a millimeter (0.01mm) reading, then see which of the lines on the vernier coincides with a line on the thimble. If it is the line marked "2" add 0.002mm, if it is the line marked "4" add 0.004mm, etc.

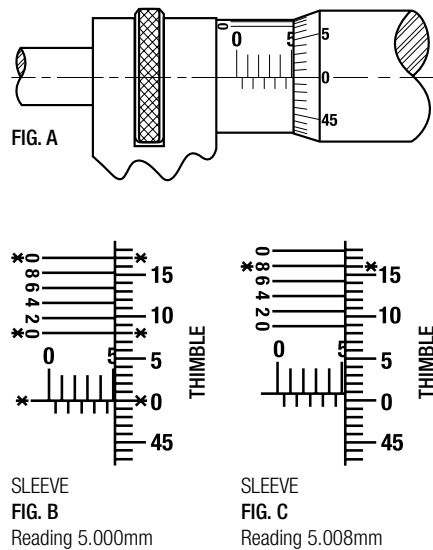

FIGURE C – READING 5.008mm

The 5mm sleeve graduation is visible 5.000mm
 No additional lines on the sleeve are visible 0.000mm
 The reading line on the sleeve lies between zero and the first line on the thimble, indicating that a vernier reading must be added.
 Line 8 on the vernier is the only line that coincides with a line on the thimble 0.008mm
 The micrometer reading is 5.008mm

GRADUATED IN ONE-THOUSANDTH OF A MILLIMETER

0.001MM

Reading a 0.001mm micrometer is exactly like reading a 0.002mm micrometer except that there are ten divisions on the vernier occupying the same space as nine divisions on the thimble (Fig. B). Therefore, the difference between the width of one of the spaces on the vernier and one of the nine spaces on the thimble is one-tenth of a division on the thimble, or one-thousandth (0.001mm).

First obtain the hundredth of a millimeter (0.01mm) reading. Next, see which of the lines on the vernier coincides with a line on the thimble. If it is the first line add

0.001mm to the reading, if it is the second line add 0.002mm, etc. Only every second vernier line is numbered on a 0.001mm reading tool because of space congestion.

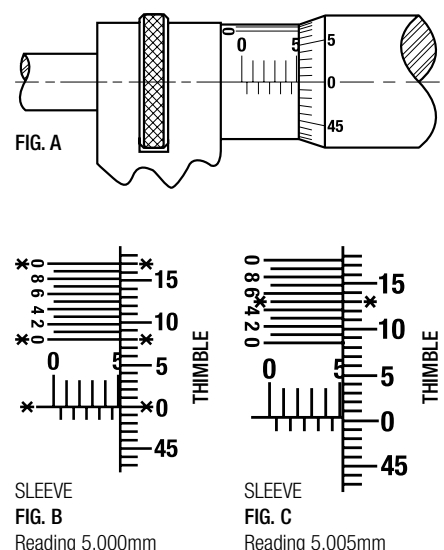

FIGURE C – READING 5.005mm

The 5mm sleeve graduation is visible, representing 5.000mm
 No additional lines on the sleeve are visible ... 0.000mm
 The reading line on the sleeve lies between zero and the first line on the thimble, indicating that a vernier reading must be added
 Line 5 on the vernier is the only line that coincides with a line on the thimble 0.005mm
 The micrometer reading is 5.005mm



ELECTRONIC MICROMETERS

795.1 ELECTRONIC MICROMETERS (WITH OUTPUT)

0-4"/0-100MM

796.1 ELECTRONIC MICROMETERS (WITHOUT OUTPUT)

0-4"/0-100MM

The expanded 795.1 and 796.1 Micrometer offering now includes measuring ranges up to 4" (100mm). All are IP67 protected against coolant, water, chips, dirt and dust. The 795.1 is equipped with an RS232 output port and is ideal for use with DataSure® Wireless Data Collection Systems or Multiplexer Inupt. Sets available upon request.

FEATURES AND SPECIFICATIONS



- Large, easy-to-read .275" (7mm), high-contrast LCD digital readout
- Starrett no-glare satin chrome finish on thimble and sleeve
- Balanced and tapered frame
- Extremely hard and stable one-piece spindle
- Micro-lapped carbide measuring faces
- Auto OFF after 20 minutes of nonuse
- Inch/millimeter conversion on English versions
- Measurement HOLD button
- Zero at any position
- Retain and return to true zero reading
- Resolution: .00005" (0.001mm)
- Accuracy: $\pm .0001$ " ($\pm .002$ mm)

795.1 Electronic Micrometers with Output						
Friction Thimble, Spindle Lock, Shell and Thimble Inch Grads.	EDP	Ratchet Stop, Lock Nut, Shell and Thimble Inch Grads.	EDP	Ratchet Thimble, Spindle Lock, Shell and Thimble Metric Grads.*	EDP	Range
Cat. No.		Cat. No.		Cat. No.		
795.1XFL-1	01100	795.1XRL-1	01108	795.1MXRL-25	01112	0-1" and 0-25mm
795.1XFL-2	01101	795.1XRL-2	01109	795.1MXRL-50	01113	1-2" and 25-50mm
795.1XFL-3	01102	795.1XRL-3	01110	795.1MXRL-75	01114	2-3" and 50-75mm
795.1XFL-4	01103	795.1XRL-4	01111	795.1MXRL-100	01115	3-4" and 75-100mm
796.1 Electronic Micrometers without Output						
796.1XFL-1	01104	796.1XRL-1	01116	796.1MXRL-25	01120	0-1" and 0-25mm
796.1XFL-2	01105	796.1XRL-2	01117	796.1MXRL-50	01121	1-2" and 25-50mm
796.1XFL-3	01106	796.1XRL-3	01118	796.1MXRL-75	01122	2-3" and 50-75mm
796.1XFL-4	01107	796.1XRL-4	01119	796.1MXRL-100	01123	3-4" and 75-100mm
Sets						
Cat. No.	EDP	Range	Description			
S795.1AXFLZ	72534	0-3" (0-75mm)	Electronic micrometer set (set of 3), includes 795.1XFL-1, 795.1XFL-2, 795.1XFL-3			
S795.1BXFLZ	72535	0-4" (0-100mm)	Electronic micrometer set (set of 4), includes 795.1XFL-1, 795.1XFL-2, 795.1XFL-3, 795.1XFL-4			
Cables and Accessories						
Cat. No.	EDP	Description				
795.1SCM	01124	SmartCable to multiplexer				
795.1SCKB	01125	USB cable to PC (In focused window)				
795.1SCU	01126	SmartCable with USB keyboard output				
PT99492	65650	Two 3-Volt Batteries, CR2032				

*Metric Only

All 795.1 and 796.1 Micrometers include a protective case. All except 1" and 0-25mm sizes furnished with standards.



IP PROTECTION

An IP number is composed of two numbers, the first referring to protection against solid objects and the second against liquids.

First number 6: Totally protected against dust

Second number 7: Protection against submersion in water under standardized conditions of pressure for 30 minutes

All 795.1 and 796.1 Micrometers include IP67 protection



ELECTRONIC MICROMETERS

3732 ELECTRONIC MICROMETERS (WITHOUT OUTPUT)

0-6"/0-150MM

The 3732 Electronic Micrometer is a full-featured precision measuring tool built with customary Starrett quality and workmanship. The 3732 includes a large, easy-to-read, high contrast LCD digital readout for clear readings. With its automatic OFF functionality, smooth friction thimble for uniform pressure, and balanced frame design, the 3732 provides comfortable and accurate measuring.

3732 Inch/Metric Micrometers without Output

Cat. No.	EDP	Range in	Approx. mm	Resolution		Accuracy	
				in	mm	in	mm
3732XFL-1	12268	0-1	0-25.4	0.0001	0.001	± 0.0001	± 0.002
3732XFL-2	12269	1-2	25.4-50.8	0.0001	0.001	± 0.0001	± 0.003
3732XFL-3	12270	2-3	50.8-76.2				
3732XFL-4	12271	3-4	76.2-101.6	0.0001	0.001	± 0.00015	± 0.004
3732XFL-5	12272	4-5	101.6-127	0.0001	0.001	± 0.00015	± 0.004
3732XFL-6	12273	5-6	127-152.4				

3732 Metric/Inch Micrometers without Output

Cat. No.	EDP	mm	Approx. in	mm		in	
				mm	in	mm	in
3732MEXFL-25	12274	0-25	0-.984	0.001	0.0001	± 0.002	± 0.0001
3732MEXFL-50	12275	25-50	.984-1.968	0.001	0.0001	± 0.003	± 0.0001
3732MEXFL-75	12276	50-75	1.968-2.953				
3732MEXFL-100	12277	75-100	2.953-3.937	0.001	0.0001	± 0.004	± 0.0001
3732MEXFL-125	12278	100-125	3.937-4.921	0.001	0.0001	± 0.004	± 0.0001
3732MEXFL-150	12279	125-150	4.921-5.905				

3732 Inch/Metric Micrometer Sets without Output

Cat. No.	EDP	in	mm	Description
S3732BXLZ	12726	0-1 to 3-4	0-25.4 to 76.2-101.6	0 to 4 inch set of four micrometers in metal case
S3732CXFLZ	12727	0-1 to 5-6	0-25.4 to 101.6-152.4	0 to 6 inch set of six micrometers in metal case

3732 Micrometer Accessories

Part No.	EDP	Description
PT99492	65650	CR2032 3-volt battery for 3732 Micrometers

All electronic micrometers include protective case

FEATURES AND SPECIFICATIONS

- Automatic OFF after 30 minutes of nonuse
- .250" (6.35mm) spindle diameter
- No-glare black wrinkle finish on frame
- No-glare satin chrome finish on thimble and sleeve
- Ring-type knurled lock nut for quick and sure locking
- English/Metric models feature inch graduations on shell and thimble
- Metric/English (ME) models have mm graduations on shell and thimble
- Instant inch/millimeter conversion
- Measurement HOLD button
- Ability to zero tool at any position
- Ability to retain and return to the true zero reading of the micrometer
- PRESET button to install any reading at any position
- Includes one 3-volt battery for over one year of normal usage



ELECTRONIC MICROMETERS

733 ELECTRONIC MICROMETERS (WITH OUTPUT)

0-24"/0-600MM

- With output to cable or DataSure® Wireless Systems

MICROMETERS

733 Electronic Micrometers with Standard Inch Graduations					
Cat. No.	EDP	Range		Resolution	
		in	mm	in	mm
733XFL-1	64239	0 - 1	0 - 25.4	0.0001	0.001
733XFL-1 W/SLC	66905				
733XFLZ-2	64241	1 - 2	25.4 - 50.8	0.0001	0.001
733XFLZ-3	64242				
733XFLZ-4	64243	3 - 4	76 - 101	0.0001	0.001
733XFLZ-5	64244				
733XFLZ-6	64245	4 - 5	101 - 127	0.0001	0.001
733XFLZ-7	64246				
733XFLZ-8	64247	5 - 6	127 - 152	0.0001	0.001
733XFLZ-9	64248				
733XFLZ-10	64249	6 - 7	152 - 178	0.0001	0.001
733XFLZ-11	64250				
733XFLZ-12	64251	7 - 8	178 - 203	0.0001	0.001
733XFLZ-13	64415				
733XFLZ-14	64416	8 - 9	203 - 228	0.0001	0.001
733XFLZ-15	64417				
733XFLZ-16	64418	9 - 10	228 - 254	0.0001	0.001
733XFLZ-17	64419				
733XFLZ-18	64420	10 - 11	254 - 279	0.0001	0.001
733XFLZ-19	64421				
733XFLZ-20	64422	11 - 12	279 - 305	0.0001	0.001
733XFLZ-21	64423				
733XFLZ-22	64424	12 - 13	305 - 330	0.0001	0.001
733XFLZ-23	64425				
733XFLZ-24	64426	13 - 14	330 - 355	0.0001	0.001
		14 - 15	355 - 381	0.0001	0.001
		15 - 16	381 - 406	0.0001	0.001
		16 - 17	406 - 432	0.0001	0.001
		17 - 18	432 - 457	0.0001	0.001
		18 - 19	457 - 482	0.0001	0.001
		19 - 20	482 - 508	0.0001	0.001
		20 - 21	508 - 533	0.0001	0.001
		21 - 22	533 - 559	0.0001	0.001
		22 - 23	559 - 584	0.0001	0.001
		23 - 24	584 - 609	0.0001	0.001

All except 1" size furnished with standards.

733 Electronic Micrometers with Standard Millimeter Graduations					
Cat. No.	EDP	Range		Resolution	
		mm	in	mm	in
733MEXFL-25	65440	0 - 25	0 - .984	0.001	0.0001
733MEXFLZ-50	65441				
733MEXFLZ-75	66079	25 - 50	.984 - 1.968	0.001	0.0001
733MEXFLZ-100	66080				
733MEXFLZ-125	66081	50 - 75	1.968 - 2.950	0.001	0.0001
733MEXFLZ-150	66082				
733MEXFLZ-175	66083	75 - 100	2.950 - 3.930	0.001	0.0001
733MEXFLZ-200	66084				
733MEXFLZ-225	66085	100 - 125	3.930 - 4.920	0.001	0.0001
733MEXFLZ-250	66086				
733MEXFLZ-275	66087	125 - 150	4.920 - 5.900	0.001	0.0001
733MEXFLZ-300	66088				
733MEXFLZ-325	66089	150 - 175	5.900 - 6.890	0.001	0.0001
733MEXFLZ-350	66090				
733MEXFLZ-375	66091	175 - 200	6.890 - 7.870	0.001	0.0001
733MEXFLZ-400	66092				
733MEXFLZ-425	66093	200 - 225	7.870 - 8.850	0.001	0.0001
733MEXFLZ-450	66094				
733MEXFLZ-475	66095	225 - 250	8.850 - 9.840	0.001	0.0001
733MEXFLZ-500	66096				
733MEXFLZ-525	66097	250 - 275	9.840 - 10.820	0.001	0.0001
733MEXFLZ-550	66098				
733MEXFLZ-575	66099	275 - 300	10.820 - 11.810	0.001	0.0001
733MEXFLZ-600	66100				
		300 - 325	11.810 - 12.790	0.001	0.0001
		325 - 350	12.790 - 13.770	0.001	0.0001
		350 - 375	13.770 - 14.760	0.001	0.0001
		375 - 400	14.760 - 15.740	0.001	0.0001
		400 - 425	15.740 - 16.730	0.001	0.0001
		425 - 450	16.730 - 17.710	0.001	0.0001
		450 - 475	17.710 - 18.700	0.001	0.0001
		475 - 500	18.700 - 19.680	0.001	0.0001
		500 - 525	19.680 - 20.660	0.001	0.0001
		525 - 550	20.660 - 21.650	0.001	0.0001
		550 - 575	21.650 - 22.630	0.001	0.0001
		575 - 600	22.630 - 23.620	0.001	0.0001

All except 1" and 0-25mm sizes furnished with standards.



733 Micrometer with DataSure End Node

733 Electronic Micrometer Accessories

Cat. No.	EDP	Description
957	66565	Protective case for 733 Micrometers
949	63874	Deluxe padded case for 25mm 733 Micrometers
733SCKB	69888	USB cable to PC (In focused window)
733SCU	69898	USB cable to computer running SPC Data Collection Software
733SCM	69893	SmartCable connection to Multiplexer (7612, 7613 or RMS 2704)
PT61963	66636	Computer Interface Cable Complete to PC (RS232C)
PT61120	65446	One 3-volt battery CR2450 for 733 Micrometers

733 Micrometer Specifications

Description	in	mm
Resolution through 4" (100mm)	.00005	0.001
Resolution over 4" (100mm)	.0001	0.001
Accuracy*	±.0001	±0.002

* Accuracies above 1" (25mm) are as good as setting to a gage because the mechanical and electronic components are the same on all ranges.
All electronic micrometers include protective case.



DIGITAL MICROMETERS

216 DIGITAL MICROMETERS

0-12"/0-300MM

This is the 216 Mechanical Digital Micrometer – simple to use even by the inexperienced. The anvil and spindle are sized at .250" (6.35mm).

READABILITY FEATURES

- Clear, easily read numbers reduce errors
- No-glare black finish on the frame
- Starrett no-glare satin chrome finish on thimble and sleeve
- .001" or .01mm is read directly from the counter
- .0001" or .001mm is read from the vernier scale on the micrometer sleeve

EASE-OF-HANDLING FEATURES

- Balanced frame design for comfortable and accurate measuring
- Ring-type knurled lock nut for quick and sure locking
- A choice of smooth friction thimble for uniform pressure on the 1-4" sizes or the combination ratchet and speeder for uniform pressure and quicker adjustment on all sizes
- Gracefully designed tapered frame for use in narrow slots and tight places

ACCURACY AND LONG-LIFE FEATURES

- Extremely hard and stable one-piece spindle (the heart of our accuracy)

S216 DIGITAL MICROMETER SET

0-3"

Set of three digital micrometers – furnished with ratchet stop, lock nut, and standards, in case.

- Set consists of three micrometers: 0-1", 1-2", and 2-3"
- .001" is read directly from the counter
- .0001" is read from the sleeve
- Clear, easily read numbers
- Balanced frame design and extremely hard and stable one-piece spindle



216 Digital Micrometers									
Ratchet Stop and Lock Nut		Friction Thimble and Lock Nut		Plain		Grads.	Range	Measuring Faces	
Cat. No.	EDP	Cat. No.	EDP	Cat. No.	EDP				
216RL-1	55953	216FL-1	55954	216P-1	55952	.001	0-1"	Steel	
216XRL-1	55955	216XFL-1	55956					Carbide	
216RL-2	56153	216FL-2	56257				1-2"		
216RL-3	56205	216FL-3	56206				2-3"		
216RL-4	56208	216FL-4	56209			.001"	3-4"	Steel	
216RL-5	63470						4-5"		
216RL-6	63471						5-6"		
216XRL-7	63628						6-7"		
216XRL-8	63629						7-8"		
216XRL-9	63630					.001"	8-9"	Carbide	
216XRL-10	63631						9-10"		
216XRL-11	63632						10-11"		
216XRL-12	63633						11-12"		
T216XRL-1	55959	T216XFL-1	55960				0-1"		
T216XRL-1 W/SLC	66904	T216XFL-1 W/SLC	66903						
T216XRL-2	56156	T216XFL-2	56157				1-2"		
T216XRL-3	63491	T216XFL-3	63634				2-3"		
T216XRL-4	63492		63635				3-4"		
T216XRL-5	63493					.0001"	4-5"	Carbide	
T216XRL-6	63494						5-6"		
T216XRL-7	63495						6-7"		
T216XRL-8	63496						7-8"		
T216XRL-9	63497						8-9"		
T216XRL-10	63498						9-10"		
T216XRL-11	63499						10-11"		
T216XRL-12	63500						11-12"		
216MXRL-25	55983	216MXFL-25	55984				0-25mm		
216MXRL-50	65602						25-50mm		
216MXRL-75	65603						50-75mm		
216MXRL-100	65604						75-100mm		
216MXRL-125	64351						100-125mm		
216MXRL-150	64352						125-150mm		
216MXRL-175	64353						150-175mm		
216MXRL-200	64354						175-200mm		
216MXRL-225	64355						200-225mm		
216MXRL-250	64356						225-250mm		
216MXRL-275	64357						250-275mm		
216MXRL-300	64358						275-300mm		
V216MXRL-25	56037	V216MXFL-25	56036				0-25mm		
V216MXRL-50	64348						25-50mm		
V216MXRL-75	64349						50-75mm		
V216MXRL-100	64350						75-100mm		

S216 Digital Micrometer Set	
Cat. No.	EDP
ST216AXRLZ	66526

Cases Only for 216 and 216M Digital Micrometers

Cat. No.	EDP	Fits Micrometer Range	
		in	mm
942	55961	0-1	0-25
216ZZ-2	56171	1-2	25-50
922	55222	2-3	50-75
952	55223	3-4	75-100
953	55224	4-5	100-125
954	55225	5-6	125-150
930	55276	6-7	150-175
931	55277	7-8	175-200
932	55278	8-9	200-225
933	55279	9-10	225-250
934	55280	10-11	250-275
935	55281	11-12	275-300



OUTSIDE MICROMETERS



230 OUTSIDE MICROMETERS

0-1"/0-25MM

This is the jewel of precision micrometers used by skilled workmen worldwide. The spindle and anvil are sized at .235" (6mm) to reach places most micrometers cannot reach.

FEATURES AND SPECIFICATIONS

- Same as our 232 Outside Micrometers plus quick-reading figures – every thousandth numbered on inch tools
- Same as our 232 Outside Micrometers with a choice of smooth friction thimble for uniform pressure or the combination ratchet and speeder for uniform pressure and quicker adjustment

230 and 230M Outside Micrometers (0-1" Range)

Cat. No.	EDP	Graduation
230P	50932	.001"
230RL	50935	
230FL	50938	
T230RL	50943	.0001"
T230XRL	50944	
T230XRL W/SLC	64401	
T230FL	50946	
T230XFL	50947	
T230XFL W/SLC	66916	0.001mm
V230MXRL	56017	
V230MXFL	56016	

Deluxe Padded Case for 230 and 230M Outside Micrometers

Cat. No.	EDP	Description
910	55397	Case for 1" (25mm) Micrometers

Case not included.

232 OUTSIDE MICROMETERS

0-1/2"/0-12.5MM

These micrometers are the 1/2" (13mm) companions of the top-of-the-line 230 Micrometers. The spindle and anvil are sized at .200" (5mm).

FEATURES AND SPECIFICATIONS

- Starrett satin chrome finish – no glare – resists rust
- Advanced sleeve design with staggered lines and distinct figures for precise and easy readability
- Convenient decimal equivalents on inch tools
- Rigid one-piece frame of drop forged steel
- Extremely hard and stable one-piece spindle (the heart of our accuracy)
- Quick and easy adjustment
- Balanced frame and thimble design ensure easy handling and better readability
- Ring-type knurled lock nut for quick and sure locking
- Combination ratchet and speeder for uniform pressure and quicker adjustment
- Gracefully designed tapered frame for use in narrow slots and tight places

232 and 232M Outside Micrometers

Cat. No.	EDP	Range	Graduation
232RL	50953	0-1/2"	.001"
T232RL	50955		.0001"
T232XRL	50968		
232MRL	50954	0-13mm	0.01mm
V232MXRL	64231		0.002mm

Attractive, Protective Case for 232 and 232M Outside Micrometers

Cat. No.	EDP	Description
921	55213	Case for 1/2" (13mm) Micrometers

Case not included.



OUTSIDE MICROMETERS

2 OUTSIDE MICROMETERS

1-2"/25-50MM

These micrometers are the 2" (50mm) companions of the top-of-the-line 230 Micrometer.

The spindle and anvil are sized at .235" (6mm) to reach places other micrometers cannot.

READABILITY FEATURES

- Starrett satin chrome finish – no glare – resists rust
- Advanced sleeve design with staggered and distinct figures for precise and easy readability
- Convenient decimal equivalents on inch tools

EASE-OF-HANDLING FEATURES

- Balanced frame and thimble design ensure easy handling and better readability
- Ring-type knurled lock nut for quick and sure locking
- A choice of smooth friction thimble for uniform pressure or the combination ratchet and speeder for uniform pressure and quicker adjustment
- Gracefully designed tapered frame for use in narrow slots and tight places

ACCURACY AND LONG-LIFE FEATURES

- Rigid one-piece frame of drop forged steel
- Extremely hard and stable one-piece spindle (the heart of our accuracy)
- Appropriate 1" or 25mm gage block standard furnished with micrometers

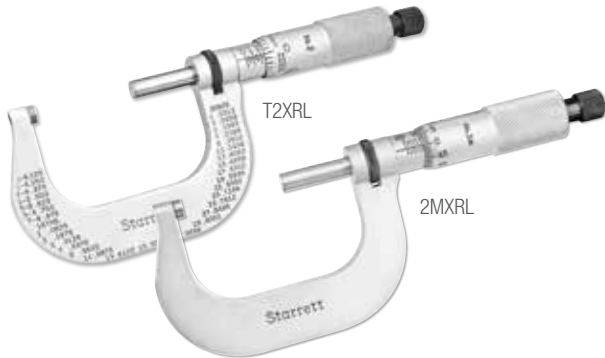

2A OUTSIDE MICROMETERS WITH ATTACHMENT

0-2"/0-50MM

These micrometers are versions of the 2 and 2M that include an attachment to handle measurements from 0-1" or 0-25mm, thereby extending the total range from 0-2" or 50mm.

Easily and quickly attached to the anvil of the micrometer, it is only necessary to tighten a locking screw to make the conversion. The anvil extension is hardened, ground and lapped. No-glare satin chrome finish.

2 and 2M Outside Micrometers			
Cat. No.	EDP	Range	Graduation
T2XRL	50024	1-2"	.0001"
T2XFL	50025		
2MXRL	50026	25-50mm	0.01mm
V2MXRL	63793		

2A and 2MA Outside Micrometer			
Cat. No.	EDP	Range	Graduation
2ARL	50027	0-2"	.001"
2MARL	50029	0-50mm	0.01mm

Deluxe Padded Case for 2, 2A, 2M and 2MA Outside Micrometers		
Cat. No.	EDP	Description
912	55399	Case for 2" and 50mm Micrometers

Micrometers furnished in a protective case.

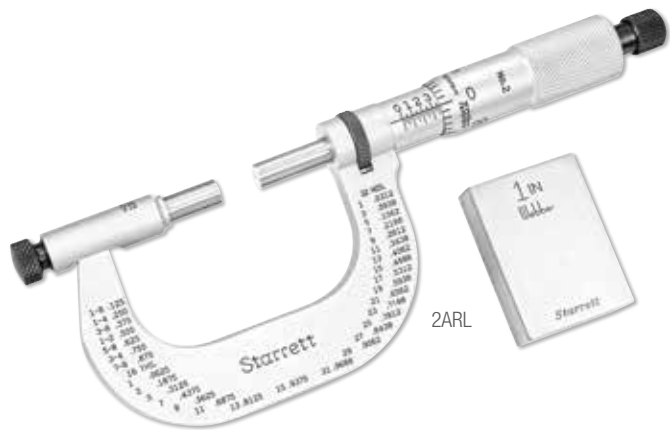

STAINLESS STEEL MICROMETERS

1230 STAINLESS STEEL MICROMETERS

0-1"/0-25MM

1212 STAINLESS STEEL MICROMETERS

1-2"/25-50MM

This micrometer is made from stainless steel for use under adverse atmospheric and operating conditions.

1230 and 1230M Stainless Steel Micrometers

Cat. No.	EDP	Range	Graduation
1230XRL	53196	0-1"	.001"
T1230XRL	53197		.0001"
V1230MXRL	64263	0-25mm	0.001mm

1212 and 1212M Stainless Steel Micrometers

Cat. No.	EDP	Range	Graduation
1212XRL	53178	1-2"	.001"
T1212XRL	53179		.0001"
V1212MXRL	64264	25-50mm	0.001mm

Deluxe Padded Cases for 1212 and 1212M Stainless Steel Micrometers

Cat. No.	EDP	Description
910	55397	Case for 1" (25mm) Micrometers
912	55399	Case for 2" (50mm) Micrometers

1" and 25mm Models sent in fitted case. 2" and 50mm Models packed one in a box without case.

READABILITY FEATURES

- Satin finish stainless steel – no glare – rust and stain resistant
- Advanced sleeve design with staggered lines and distinct figures for precise and easy readability
- Convenient decimal equivalents on inch tools

EASE-OF-HANDLING FEATURES

- Balanced frame and thimble design ensure easy handling and better readability
- Ring-type knurled lock nut for quick and sure locking
- The combination ratchet and speeder for uniform pressure and quicker adjustment
- Gracefully designed tapered frame for use in narrow slots and tight places

ACCURACY AND LONG-LIFE FEATURES

- Rigid one-piece frame of drop forged steel
- Extremely hard and stable one-piece spindle (the heart of our accuracy)
- Quick and easy adjustment
- Gage block standard supplied for 1-2" micrometer

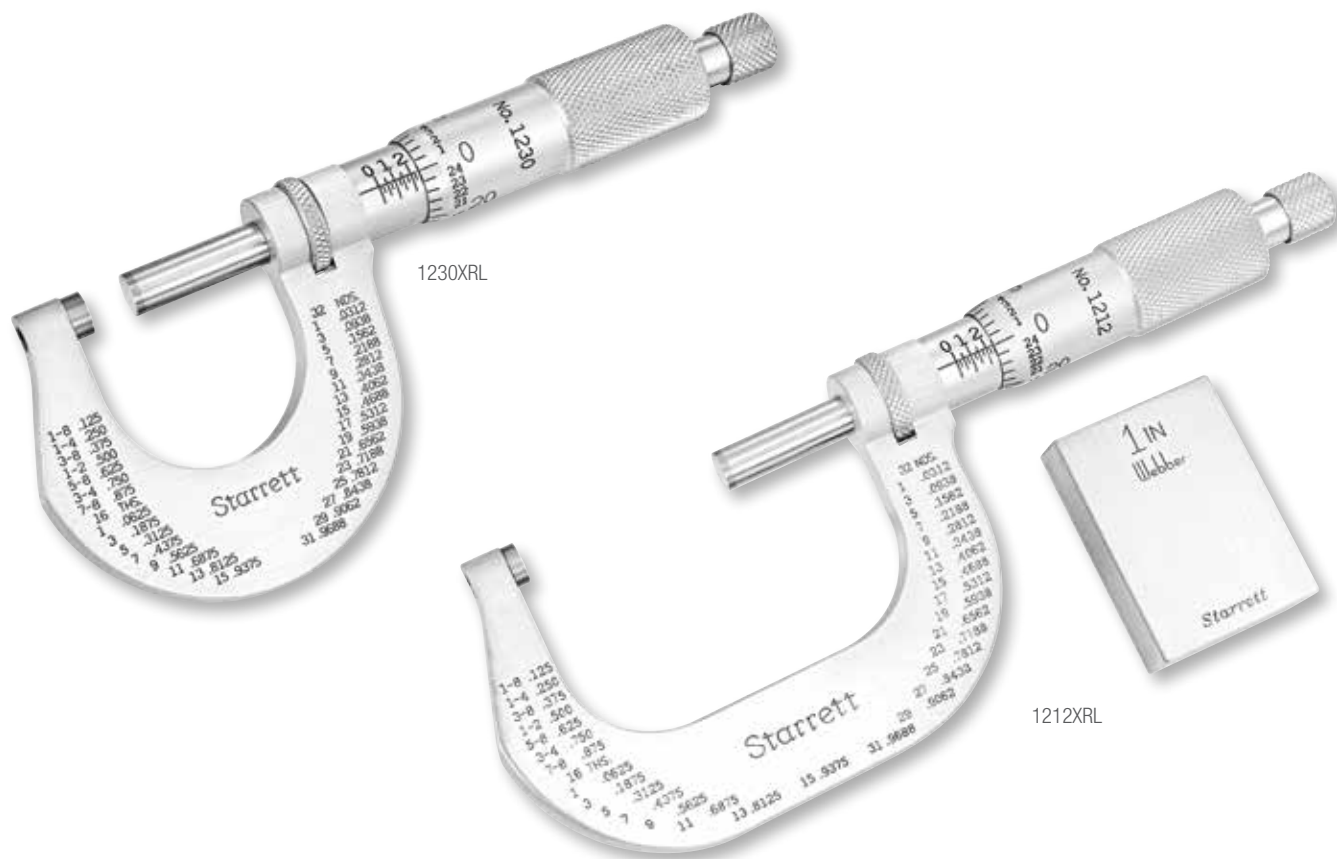

OUTSIDE MICROMETERS

NEW!

T444.1 OUTSIDE MICROMETER

The T444.1 Outside Micrometers have a heat-insulator on the frame to help reduce temperature-related expansion or contraction. The spindle and anvil have flat measuring faces and are carbide-tipped for wear resistance. A spindle lock helps provide secure locking of the measurement.

FEATURES

- No-glare satin chrome finish which resists rust
- Advanced sleeve design with staggered lines and distinct figures for precise and easy readability
- Balanced frame and thimble design to ensure easy handling and better readability
- Insulated frame for prevention of temperature related expansion and contraction
- Provides quick and easy adjustment
- Reading in ten-thousandths of an inch (.0001") with a vernier scale on the sleeve

MICROMETERS

Cat. No.	EDP	Graduation	Range
T444.1XRL-1	52083	.0001"	0-1"
T444.1XRL-2	52084	.0001"	1-2"
T444.1XRL-3	52085	.0001"	2-3"
T444.1XRL-4	52086	.0001"	3-4"
T444.1XRL-5	52087	.0001"	4-5"
T444.1XRL-6	52088	.0001"	5-6"
444.1MXRL-25	51072	.01mm	0-25mm
444.1MXRL-50	51073	.01mm	25-50mm
444.1MXRL-75	51085	.01mm	50-75mm
444.1MXRL-100	51088	.01mm	75-100mm
444.1MXRL-125	51091	.01mm	100-125mm
444.1MXRL-150	91094	.01mm	125-150mm

Sets				
Cat. No.	EDP	Graduation	Range	Description
ST444.1BXRLZ	72531	.0001"	0-4"	Set of four micrometers in metal case
ST444.1CXRLZ	72532	.0001"	0-6"	Set of four micrometers in metal case
S444.1MBXRLZ	21089	.01mm	0-100mm	Set of four micrometers in metal case
S444.1MCXRLZ	21090	.01mm	0-150mm	Set of four micrometers in metal case

All micrometers and sets furnished with a protective case.



T444.1XRL-4

T444.1XRL-1



MICROMETERS

231, 231M MICROMETERS WITH INSULATED FRAMES

0-1"/0-25MM

This is a slightly heavier micrometer with thermal insulators mounted on the frame front and rear. This spindle and anvil are sized at .250" (6.35mm).

READABILITY FEATURES

- Starrett satin chrome finish – no glare – resists rust
- Advanced sleeve design with staggered lines and distinct figures for precise and easy readability
- Quick-reading figures – every thousandth numbered on inch tools

EASE-OF-HANDLING FEATURES

- Balanced frame and thimble design ensure easy handling and better readability
- Ring-type knurled lock nut for quick and sure locking
- A combination ratchet and speeder for uniform pressure and quicker adjustment on all sizes
- Gracefully designed tapered frame for use in narrow slots and tight places

ACCURACY AND LONG-LIFE FEATURES

- Rigid one-piece frame of drop forged steel
- Extremely hard and stable one-piece spindle (the heart of our accuracy)
- Quick and easy adjustment

221 HI-PRECISION MICROMETER

0-1"

- Permits direct readings in ten-thousandths of an inch (.0001") without a vernier, plus automatic control of spindle pressure
- Black graduated inner thimble and sleeve reading in thousandths and red graduated outer thimble and sleeve with large, widely spaced graduations which give direct readings in ten-thousandths

READABILITY FEATURES

- Exclusive constant pressure mechanism eliminates "feel" and ensures constant spindle pressure for all readings
- Starrett satin chrome finish – no glare – resists rust
- Advanced sleeve design with staggered lines and distinct figures for precise and easy readability
- Convenient decimal equivalents on inch tools

EASE-OF-HANDLING FEATURES

- Balanced frame and thimble design for easy handling and better readability
- Ring-type knurled lock nut for quick and sure locking
- Gracefully designed tapered frame for use in narrow slots and tight places

ACCURACY AND LONG-LIFE FEATURES

- Rigid one-piece frame of drop forged steel
- Extremely hard and stable one-piece spindle (the heart of our accuracy)
- Quick and easy adjustment

231 and 231M Micrometers (0-1" Range)

Cat. No.	EDP	Range	Graduation
T231XRL	63967	0-1"	.0001"
V231MXRL	63969	0-25mm	0.001mm

Deluxe Padded Case for 231 and 231M Micrometers

Cat. No.	EDP	Description
942	55961	Case for 1" (25mm) Micrometers

221 Hi-Precision Micrometer (0-1" Range)

Cat. No.	EDP	Graduation
T221XL	50754	.0001"

Deluxe Padded Case for 221 Hi-Precision Micrometer

Cat. No.	EDP	Description
910	55397	Case for 1" (25mm) Micrometers



V231MXRL

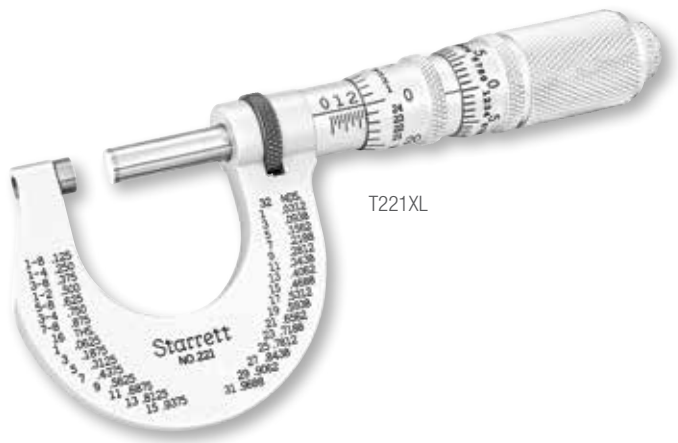

T221XL



ST226AXRLZ



T226XRL-1

OUTSIDE MICROMETERS

226 OUTSIDE MICROMETERS

1-6"/25-150MM

- Rugged construction and extremely attractive design
- For craftsmen who want a precision micrometer with a distinctive Starrett design and finish
- Strong ribbed frame with smooth black enamel finish and polished steel ribs and hub

S226 MICROMETER SETS WITH STANDARDS IN CASE

0-6"/0-150MM

These sets are recommended for mechanics, automotive service and machine shops, toolrooms, inspection departments, and wherever gaging involves a wide range of measurements.

READABILITY FEATURES

- Starrett satin chrome finish – no glare – resists rust
- Advanced sleeve design with staggered lines and distinct figures for precise and easy readability
- Quick-reading figures – every thousandth numbered on inch tools

EASE-OF-HANDLING FEATURES

- Balanced frame and thimble design ensure easy handling and better readability
- Ring-type knurled lock nut for quick and sure locking

ACCURACY AND LONG-LIFE FEATURES

- Rugged frame ribbed for extra strength
- Extremely hard and stable one-piece spindle (the heart of our accuracy)
- Quick and easy adjustment

226 Outside Micrometers (.001" Graduation)				
Ratchet Stop and Lock Nut		Standard (extra)		Range
Cat. No.	EDP	Cat. No.	EDP	
226RL-1	12209			0-1"
226RL-2	50820	234B-1	51017	1-2"
226RL-3	50825	234B-2	51019	2-3"
226RL-4	50830	234B-3	51021	3-4"
226RL-5	50835	234B-4	51023	4-5"
226RL-6	50840	234B-5	51025	5-6"

226 Outside Micrometers, Carbide Faces (.0001" Graduation)				
Cat. No.	EDP	Standard	EDP	Range
T226XRL-1	12211			0-1"
T226XRL-2	50903	234B-1	51017	1-2"
T226XRL-3	50904	234B-2	51019	2-3"
T226XRL-4	50905	234B-3	51021	3-4"
T226XRL-5	50906	234B-4	51023	4-5"
T226XRL-6	50907	234B-5	51025	5-6"

226M Outside Micrometers, Carbide Faces (0.001mm Graduation)				
Cat. No.	EDP	Standard	EDP	Range
V226MXRL-25	12212			0-25mm
V226MXRL-50	64265	234MB-25	51018	25-50mm
V226MXRL-75	64266	234MB-50	51020	50-75mm
V226MXRL-100	64267	234MB-75	51022	75-100mm
V226MXRL-125	64268	234MB-100	51024	100-125mm
V226MXRL-150	64269	234MB-125	51026	125-150mm

Micrometer Cases for 226 and 226M Outside Micrometers		
Cat. No.	EDP	Description
910	55397	for 1" (25mm)
913	55400	for 2" (50mm)
922	55222	for 3" (75mm)
952	55223	for 4" (100mm)
953	55224	for 5" (125mm)
954	55225	for 6" (150mm)

Furnished in an attractive protective case.

S226 and S226M Micrometer Sets				
Cat. No.	EDP	Range	Graduation	Set Description
S226ARLZ	50854	0-3"	.001"	Includes 1", 2" and 3" Micrometers, Two Standards, Adjusting Wrench
ST226AXRLZ	56448		.0001"	
S226BRLZ	50862	0-6"	.001"	Includes 1", 2", 3", 4", 5" and 6" Micrometers, Set of Five Standards, Adjusting Wrench
ST226BXRZLZ	56798		.0001"	
SV226MAXRLZ	65237	0-75mm	0.001mm	Includes 25mm, 50mm and 75mm Micrometers, Two Standards, Adjusting Wrench
SV226MBXRZLZ	65238	0-150mm	0.001mm	Includes 25mm, 50mm, 75mm, 100mm, 125mm and 150mm Micrometers, Set of Five Standards, Adjusting Wrench

Cases Only for S226 and S226M Micrometer Sets		
Cat. No.	EDP	Description
955	55226	Case for 0-3" and 0-75mm Micrometer Sets
956	55227	Case for 0-6" and 0-150mm Micrometer Sets



OUTSIDE MICROMETERS

436.1 OUTSIDE MICROMETERS

0-6"

These are the most popular precision micrometers used by skilled workmen worldwide. They are accurate, rugged, and easy to use.

The 0-6" and 0-150mm sizes have rugged spindles and anvils at .250" (6.35mm) diameter.

436.1 Outside Micrometers (0-1" Range)		436.1 Outside Micrometers (1-2" Range)		
Cat. No.	EDP	Cat. No.	EDP	Graduation
436.1P-1	67990	436.1P-2	68001	.001"
436.1XP-1	67991			
436.1RL-1	67993	436.1RL-2	68002	
436.1XRL-1	67994	436.1XRL-2	68003	
436.1XRL-1 W/SLC	67995			
436.1FL-1	67996	436.1FL-2	68004	
T436.1XP-1	67992			
T436.1XRL-1	67997	T436.1XRL-2	68005	
T436.1XRL-1 W/SLC	67998	T436.1XRL-2 W/SLC	68006	
T436.1XFL-1	67999	T436.1XFL-2	68007	
T436.1XFL-1 W/SLC	68000	T436.1XFL-2 W/SLC	68008	
				.0001"
				.001"
				.0001"
				.001"
				.0001"

Sent in fitted plastic case.

FEATURES AND SPECIFICATIONS

- Starrett satin chrome finish – no glare – resists rust
- Advanced sleeve design with staggered lines and distinct figures for precise and easy readability
- Balanced frame and thimble design ensure easy handling
- Ring-type knurled lock nut for quick and sure locking
- Smooth friction thimble for uniform pressure, the combination ratchet and speeder for uniform pressure and quicker adjustment, or a plain micrometer that depends on your own "feel"
- Gracefully designed tapered frame for use in narrow slots and tight places
- Rigid steel frame ribbed for extra strength on sizes through 6" (150mm)
- Extremely hard and stable one-piece spindle (the heart of our accuracy)
- Quick and easy adjustment



T436.1XRL-2

436.1P-1

See following page for listing of Cases and Standards

OUTSIDE MICROMETERS

436.1 OUTSIDE MICROMETERS

6-24" (0-600MM)

Same balanced design as the smaller sizes but proportioned to these larger sizes with .300" (7.6mm) anvil and spindle diameters for ease of use on larger work.

All the same features as the 0-6" and 0-150mm ranges 436.1 Micrometers, except:

- Larger sizes are furnished with combination ratchet and speeder for uniform pressure and quicker adjustment
- Rigid and stable special cast iron frame with perforations for lightness and ribbed for strength and stability

436 Outside Micrometers			
Cat. No.	EDP	Range	Graduation
436.1RL-7	72710	6-7"	.001"
436.1XRL-7	72716		
T436.1XRL-7	72734		
436.1RL-8	72711	7-8"	.001"
436.1XRL-8	72717		
T436.1XRL-8	72735		
436.1RL-9	72712	8-9"	.001"
436.1XRL-9	72718		
T436.1XRL-9	72736		
436.1RL-10	72713	9-10"	.001"
436.1XRL-10	72719		
T436.1XRL-10	72737		
436.1RL-11	72714	10-11"	.001"
436.1XRL-11	72720		
T436.1XRL-11	72738		
436.1RL-12	72715	11-12"	.001"
436.1XRL-12	72721		
T436.1XRL-12	72739		
436.1XRLZ-13	72722	12-13"	.001"
436.1XRLZ-14	72723	13-14"	
436.1XRLZ-15	72724	14-15"	
436.1XRLZ-16	72725	15-16"	
436.1XRLZ-17	72726	16-17"	
436.1XRLZ-18	72727	17-18"	
436.1XRLZ-19	72728	18-19"	
436.1XRLZ-20	72729	19-20"	
436.1XRLZ-21	72730	20-21"	
436.1XRLZ-22	72731	21-22"	
436.1XRLZ-23	72732	22-23"	
436.1XRLZ-24	72733	23-24"	

7-12" models sent without case, packed one each to a box.
13-24" models are furnished in a case at no extra charge.

436 Outside Micrometers			
Cat. No.	EDP	Range	Graduation
436.1MP-25	68047	0-25mm	0.01mm
436.1MRL-25	68048		
436.1MXFL-25	68050		
V436.1MXRL-25	68051		
436.1MXRL-25	68049	0-25mm	0.001mm
436.1MRL-50	68052	25-50mm	0.01mm
436.1MXRL-50	68053		
V436.1MXRL-50	68054	25-50mm	0.001mm
436.1MRL-75	68055	50-75mm	0.01mm
436.1MXRL-75	68056		
V436.1MXRL-75	68057	50-75mm	0.001mm
436.1MRL-100	68058	75-100mm	0.01mm
436.1MXRL-100	68059		
V436.1MXRL-100	68060	75-100mm	0.001mm
436.1MRL-125	68061	100-125mm	0.01mm
436.1MXRL-125	68062		
V436.1MXRL-125	68063	100-125mm	0.001mm
436.1MRL-150	68064	125-150mm	0.01mm
436.1MXRL-150	68065		
V436.1MXRL-150	68066	125-150mm	0.001mm
436.1MXRL-175	72740	150-175mm	0.01mm
436.1MXRL-200	72741	175-200mm	
436.1MXRL-225	72742	200-225mm	
436.1MXRL-250	72743	225-250mm	
436.1MXRL-275	72744	250-275mm	
436.1MXRL-300	72745	275-300mm	
436.1MXRLZ-325	72746	300-325mm	
436.1MXRLZ-350	72747	325-350mm	
436.1MXRLZ-375	72748	350-375mm	
436.1MXRLZ-400	72749	375-400mm	
436.1MXRLZ-425	72750	400-425mm	
436.1MXRLZ-450	72751	425-450mm	
436.1MXRLZ-475	72752	450-475mm	
436.1MXRLZ-500	72453	475-500mm	
436.1MXRLZ-525	72754	500-525mm	
436.1MXRLZ-550	72755	525-550mm	
436.1MXRLZ-575	72756	550-575mm	
436.1MXRLZ-600	72757	575-600mm	

25-150mm models sent in fitted plastic case. 175-300mm models sent without case, packed one each to a box.
325-600mm models are furnished in a case at no extra charge.

MEASURING RODS AND STANDARDS CAN BE FOUND ON PAGE 76



436.1RL-12

914
Leather Holster

Holster and Cases for Inch and Millimeter Micrometers		
Cat. No.	EDP	Description
914	64165	Leather holster for 1" (25mm) micrometers
910	55397	Case for 1" (25mm) micrometers
913	55400	Case for 2" (50mm) micrometers
922	55222	Case for 3" (75mm) micrometers
952	55223	Case for 4" (100mm) micrometers
953	55224	Case for 5" (125mm) micrometers
954	55225	Case for 6" (150mm) micrometers
930	55276	Case for 7" (175mm) micrometers
931	55277	Case for 8" (200mm) micrometers
932	55278	Case for 9" (225mm) micrometers
933	55279	Case for 10" (250mm) micrometers
934	55280	Case for 11" (275mm) micrometers
935	55281	Case for 12" (300mm) micrometers



MICROMETER SETS

S436.1 MICROMETER SETS WITH STANDARDS, IN ATTRACTIVE, PROTECTIVE CASES

0-24" (0-600MM)

Recommended for mechanics, automotive service and machine shops, toolrooms, inspection departments, and wherever gaging involves a wide range of measurements. All sets come with attractive, protective cases which keep micrometers and standards together, readily accessible.

For further information on each type of micrometer, refer to the listing on the previous pages.



ST436.1AXRLZ

S436.1 Micrometer Sets

Cat. No.	EDP	Range	Graduation	Set Description
S436.1ARLZ	68035	0-3"	.001"	Each Set Includes: 1", 2" and 3" micrometers, with two standards
S436.1AXRLZ	68036			
ST436.1AXRLZ	68037		.0001"	
ST436.1AXFLZ	68038			
S436.1BRLZ	68039	0-4"	.001"	Each Set Includes: 1", 2", 3" and 4" micrometers, with three standards
S436.1BXRLZ	68040			
ST436.1BXRLZ	68041		.0001"	
ST436.1BXFLZ	68042			
S436.1CRLZ	68043	0-6"	.001"	Each Set Includes: 1", 2", 3", 4", 5" and 6" micrometers, with five standards
S436.1CXRLZ	68044			
ST436.1CXRLZ	68045		.0001"	
ST436.1CXFLZ	68046			

S436 Micrometer Sets

Cat. No.	EDP	Range	Graduation	Set Description
S436ERLZ	51931	0-12"	.001"	Each Set Includes: 1", 2", 3", 4", 5", 6", 7", 8", 9", 10", 11" and 12" micrometers, with eleven standards
S436EXRLZ	52012			
ST436EXRLZ	52030		.0001"	
S436DRLZ	51919	6-12"	.001"	Each Set Includes: 7", 8", 9", 10", 11" and 12" micrometers, with six standards
S436DXRLZ	64463			
ST436DXRLZ	64465		.0001"	
S436FXRLZ	64466	12-24"	.001"	Set Includes: 13", 14", 15", 16", 17", 18", 19", 20", 21", 22", 23" and 24" micrometers, with twelve standards

Box type cases available for sets 0-6", 6-12", 12-24" with 6, 12, or 24 micrometers and flat type cases available for sets 0-3" or 0-4" with 3 or 4 micrometers.

S436.1M Micrometer Sets

Cat. No.	EDP	Range	Graduation	Set Description
S436.1MARLZ	68067	0-75mm	0.01mm	Each Set Includes: 25mm, 50mm and 75mm micrometers, with two standards
S436.1MAXRLZ	68068			
SV436.1MAXRLZ	68069		0.001mm	
S436.1MBRLZ	68070	0-100mm	0.01mm	Each Set Includes: 25mm, 50mm, 75mm and 100mm micrometers with three standards
S436.1MBXRLZ	68071			
SV436.1MBXRLZ	68072		0.001mm	
S436.1MCRLZ	68073	0-150mm	0.01mm	Each Set Includes: 25mm, 50mm, 75mm, 100mm, 125mm and 150mm micrometers, with five standards
S436.1MCXRLZ	68074			
SV436.1MCXRLZ	68075		0.001mm	

S436M Micrometer Sets

Cat. No.	EDP	Range	Graduation	Set Description
S436MEXRLZ	52014	0-300mm	0.01mm	Set Includes: 25, 50, 75, 100, 125, 150, 175, 200, 225, 250, 275 and 300mm micrometers, with eleven standards
S436MDXRLZ	64461	150-300mm	0.01mm	Set Includes: 175, 200, 225, 250, 275 and 300mm micrometers, with six standards
S436MFXRLZ	64462	300-600mm	0.01mm	Set Includes: 325, 350, 375, 400, 425, 450, 475, 500, 525, 550, 575 and 600mm micrometers, with twelve standards

Box type cases available for sets 0-150mm, 150-300mm, 300-600mm with 6, 12, or 24 micrometers and flat type cases available for sets 0-75mm or 0-100mm with 3 or 4 micrometers.

Cases for S436.1 and S436 Micrometer Sets

Cat. No.	EDP	Description
955	55226	Case only for S436A sets
936	55295	Case only for S436B sets
956	55227	Case only for S436C sets
938	55298	Case only for S436E sets
937	55297	Case only for S436D sets
S436FZZ	64339	Case only for S436F sets

* Includes redemption card for Standard Letter of Certification (SLC).

MEASURING RODS AND STANDARDS CAN BE FOUND ON PAGE 76



ANVIL MICROMETERS

224.1 MECHANICAL INTERCHANGEABLE ANVIL MICROMETER

0-24"/0-600MM

Increased flexibility by offering a wide range of measurements. The 224 Satin-Chrome Micrometers are very popular in machine or automotive repair shops and for all applications requiring a single micrometer with range greater than 1".

Each micrometer is equipped with a series of easily interchangeable anvils, thus providing the full range in steps of 1" or 25mm with a single micrometer. Suitable wrenches are furnished to make necessary adjustments.

These larger sizes have .300" (7.6mm) anvil and spindle diameters for ease of use on larger work.

224, 224M, 224.1, 24.1M Interchangeable Anvil Micrometers

With Ratchet Stop, Lock Nut, In Case		Range	Graduation	234 Standards Furnished
Cat. No.	EDP			
224AARLZ	50770	0-4"	.001"	1", 2", 3"
224ARLZ	50772	2-6"		2", 3", 4", 5"
224.1BRLZ	72700	6-9"		6", 7", 8"
224.1GRLZ	72704	6-12"		6", 7", 8", 9", 10", 11"
224.1CRLZ	72701	9-12"		9", 10", 11"
224.1DRLZ	72702	12-16"		12", 13", 14", 15"
224.1ERLZ	72703	16-20"		16", 17", 18", 19"
224.1JRLZ	72705	20-24"	20", 21", 22", 23"	
224MAARLZ	50771	0-100mm	0.01mm	25, 50, 75mm
224MARLZ	50773	50-150mm		50, 75, 100, 125mm
224.1MGRLZ	72708	150-300mm		150, 175, 200, 225, 250, 275mm
224.1MDRLZ	72706	300-400mm		300, 325, 350, 375mm
224.1MERLZ	72707	400-500mm		400, 425, 450, 475mm
224.1MJRLZ	72709	500-600mm		500, 525, 550, 575mm

Micrometer furnished in attractive, protective case.

READABILITY FEATURES

- Starrett satin chrome finish – no glare – resists rust
- Advanced sleeve design with staggered lines and distinct figures for precise and easy readability
- Large thimble diameter with distinct figures

EASE-OF-HANDLING FEATURES

- Balanced frame and thimble design ensure easy handling and better readability
- Ring-type knurled lock nut for quick and sure locking
- Combination ratchet and speeder for uniform pressure and quicker adjustment

ACCURACY AND LONG-LIFE FEATURES

- Rigid and stable special cast iron frame with appropriate perforations for lightness and ribbed for strength and stability
- Extremely hard and stable one-piece spindle (the heart of our accuracy)
- Quick and easy sleeve adjustment



224.1CRLZ



ANVIL MICROMETERS

714 ELECTRONIC INTERCHANGEABLE ANVIL OUTSIDE MICROMETERS (WITH OUTPUT)

0-24"/0-600MM

This micrometer is the same as our 224 Micrometers except that it has an electronic readout and the following extra features and benefits:

714 Electronic Interchangeable Anvil Micrometers With Standard Inch Graduations on Shell and Thimble

Cat. No.	EDP	Range		Resolution	
		in	Approx. mm	in	mm
714AAFLZ	64427	0-4	0-101	.00005	0.001
714AFLZ	64428	2-6	51-152	.0001	0.001
714BFLZ	64429	6-9	152-228		
714GFLZ	64430	6-12	152-305		
714CFLZ	64431	9-12	228-305		
714DFLZ	64432	12-16	305-406		
714EFLZ	64433	16-20	406-508		
714JFLZ	64434	20-24	508-609		

714M Electronic Interchangeable Anvil Micrometers With Standard Millimeter Graduations on Shell and Thimble

Cat. No.	EDP	Range		Resolution	
		mm	Approx. in	mm	in
714MEAAFLZ	66108	0-100	0-3.930	0.001	.00005
714MEAFLZ	66109	50-150	1.968-5.900	0.001	.0001
714MEGFLZ	66111	150-300	5.900-11.810		
714MEDFLZ	66112	300-400	11.810-15.740		
714MEEFLZ	66113	400-500	15.740-19.680		
714MEJFLZ	66110	500-600	19.680-23.620		

Cable Information for 714 and 714M Electronic Interchangeable Anvil Micrometers

Part No.	EDP	Description
PT61963	66636	Computer Interface Cable Complete to PC (RS232C)
733SCKB	69888	USB cable to PC (In focused window)
733SCU	69898	USB cable to computer running SPC Data Collection Software
733SCM	69893	Connection to Multiplexer (7612, 7613 or RMS 2704)
PT61120	65446	One 3-Volt Battery CR2450

Adjusting wrenches furnished with each tool.
Micrometer furnished in protective case with 234 Standards.

READABILITY FEATURES

- Large, right-sized, high-contrast LCD digital readout is easy to read and reduces errors
- Resolution – .00005" and 0.001mm
- Conventional inch or millimeter graduations standard
- Starrett no-glare satin chrome finish on thimble and sleeve

ACCURACY AND LONG-LIFE FEATURES

- One 3-volt battery furnished for dependable power and over one year's normal usage
- Automatic OFF after 30 minutes of nonuse

FULL-FUNCTION ACTION FEATURES

- Instant inch/millimeter conversion
- "ME" millimeter models will turn on in the millimeter mode after installation of a new battery
- Measurement HOLD button
- Ability to zero tool at any position
- Ability to retain and return to the true zero reading of the micrometer
- PRESET button to install any reading at any position
- Ability to install minimum and maximum limits
- Output data to Starrett SPC Plus hardware and software and to PCs
- Works well with Starrett DataSure® Wireless Data Collection Systems



714MEAFLZ

714EFLZ



TUBULAR MICROMETERS

724 TUBULAR BOW TYPE MICROMETERS WITH INTERCHANGEABLE ANVILS

12-60"/300 -1500MM

These micrometers are made for more precise measurements on large outside dimensions. They provide perfect balance, sensitive feel, ease of handling, and less measuring effort due to their advanced tubular design. Frames are built of special steel formed to exacting tubular design specifications and welded by a carefully controlled process. This produces a hollow tubular frame of the lightest weight, extreme rigidity, and a standard coefficient of expansion.

Because of the interchangeable anvils, the 724 is well suited for diversified gaging and provides a wide range of measurement in steps of 1 inch or 25mm.

The micrometer head has a larger diameter anvil and spindle at .300" (7.6mm). This provides greater balance and larger bearing surface on the threads.

724 Tubular Bow Type Micrometers				
With Lock Nut, In Case				
Cat. No.	EDP	Range (in)	Graduation	234 Standards Furnished
724LZ-18	52994	12-18	.001"	12", 13", 14", 15", 16", 17"
724LZ-24	52995	18-24		18", 19", 20", 21", 22", 23"
724LZ-30	52996	24-30		25", 27", 29"
724LZ-36	52997	30-36		31", 33", 35"
724LZ-42	52998	36-42		37", 39", 41"
724LZ-48	52999	42-48		43", 45", 47"
724LZ-54	53000	48-54		49", 51", 53"
724LZ-60	53001	54-60		55", 57", 59"
724M Tubular Bow Type Micrometers				
With Lock Nut, In Case				
Cat. No.	EDP	Range (mm)	Graduation	234 Standards Furnished
724MLZ-450	64318	300-450	0.01mm	300, 325, 350, 375, 400, 425mm
724MLZ-600	64319	450-600		450, 475, 500, 525, 550, 575mm
724MLZ-750	64320	600-750		625, 675, 725mm
724MLZ-900	64321	750-900		775, 825, 875mm
724MLZ-1050	64322	900-1050		925, 975, 1025mm
724MLZ-1200	64323	1050-1200		1075, 1125, 1175mm
724MLZ-1350	64324	1200-1350		1225, 1275, 1325mm
724MLZ-1500	64325	1350-1500		1375, 1425, 1475mm

Adjusting wrenches furnished with each tool.
Furnished with 234 Standards in attractive, protective case.

READABILITY FEATURES

- Starrett satin chrome finish – no glare – resists rust
- Advanced sleeve design with staggered lines and distinct figures for precise and easy readability
- Large thimble diameter with distinct figures

EASE-OF-HANDLING FEATURES

- Balanced frame and thimble design for easy handling and better readability
- Ring-type knurled lock nut for quick and sure locking
- Hollow tubular frame design combining lightest possible weight with rigidity

ACCURACY AND LONG-LIFE FEATURES

- Extremely hard and stable one-piece spindle (the heart of our accuracy)
- Standards with insulated grips
- It is recommended that these micrometers be checked with standards in the approximate position (vertical or horizontal) that they will be used. We do not recommend .0001" or 0.001mm readings on these micrometers. Larger sizes, carbide faces and ratchet stop are available on special order.



724LZ-18



TUBULAR MICROMETERS

736 TUBULAR BOW TYPE MICROMETERS WITH FIXED ANVIL

12-30"/300-750MM

This micrometer is similar to the 724 Micrometer. All features are identical to the 724, except that it has a fixed anvil, and is furnished in inch and millimeter sizes from 12-30" and 25mm increments from 300-750mm.

Order by catalog number and range through our Special Order Department. Example: 736LZ-28 (this orders a micrometer with a 27-28" range with lock nut and standard, in an attractive, protective case.)

A fixed anvil makes it easier to gage an outside diameter because the balance of the gage is proportional to the part being measured.

READABILITY FEATURES

- Starrett satin chrome finish – no glare – resists rust
- Advanced sleeve design with staggered lines and distinct figures for precise and easy readability
- Large thimble diameter with distinct figures

EASE-OF-HANDLING FEATURES

- Balanced frame and thimble design ensure easy handling and better readability
- Ring-type knurled lock nut for quick and sure locking

ACCURACY AND LONG-LIFE FEATURES

- Hollow tubular frame design combining lightest possible weight with rigidity
- Extremely hard and stable one-piece spindle (the heart of our accuracy)
- 234 Standards furnished with micrometers



736LZ-31

ULTRALIGHT "C" FRAME GAGES

Rigid honeycomb aluminum diameter gage weighs five times less than solid frame gages. Unit shown has interchangeable anvils for 36-42" range. The gage is used as a dial indicator snap gage set to produce nominal dimension, or as an indicating micrometer. The micrometer head with .0001" graduations and the .0005" dial indicator ensure quick, accurate readings.

Ultralights are available from 24-72" (600-1800mm) I.D. or O.D. and can be designed for up to 72" (1800mm) throat depth for thickness measurement.

MICROMETER STANDS

3206 OUTSIDE MICROMETER STAND

- This stand converts outside micrometers to a sturdy bench gage for batch inspection of small parts
- Useful as a handy bench vise or assembly fixture
- Gripping surfaces are two nylon pads which are replaceable
- Ball joint construction allows head to be positioned as much as 30° off perpendicular in any direction
- Positive lock on the base
- Base dimension is 6-3/8" long x 3-1/2" wide x 3/4" thick (162mm long x 89mm wide x 19mm thick)
- Tilting head clamping capability is 3/4" (19mm) thick x 1" (25mm) throat depth
- Accommodates all Starrett 1/2" (13mm) and 1" (25mm) outside micrometers, 2 and 2A 2" outside micrometers and 210, 220, 430, 483, 485 and 569 Special Purpose Outside Micrometers

3206 Outside Micrometer Stand

Cat. No.	EDP	Description
3206	68917	Outside Micrometer Stand



SPECIAL FUNCTION MICROMETERS

MICROMETER HEAD SPEEDS GAGING

Unique applications can require unique tools. Starrett is constantly building special tools in large and small quantities with unique functionality. Special function micrometers have unique frames, contacts, readouts, or other components that will meet your requirements. Quotations and a concept print for your application can be obtained by submitting a product drawing with the thickness dimension(s) circled to:

The L.S. Starrett Co.
 Special Gage Division
 121 Crescent Street
 Athol, MA 01331-1915.



Special 436 Micrometer with dial indicator head. Range 3-4" (75-100mm). Other ranges also available.



Starrett can manufacture extra large micrometers, like this special 724 Micrometer of tubing type construction, range 72-78" (1800-1950mm), with interchangeable anvils.

CONTACTS

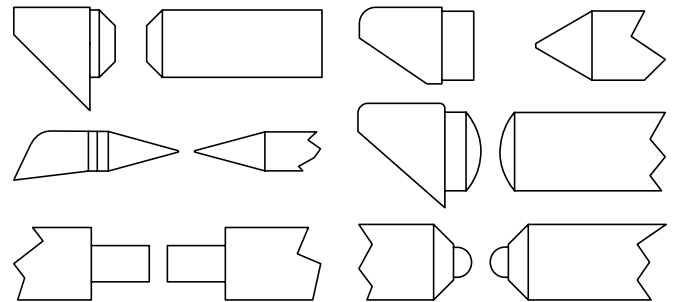

SPECIAL 725 DEEP THROAT TUBULAR MICROMETER

With sliding, interchangeable anvils and locking lever, 7-1/2" (185mm) depth, 0-6" (0-150mm) range.



SPECIAL FUNCTION MICROMETERS

Throughout its history, The L.S. Starrett Company has manufactured a multitude of special hand tools and gages for thousands of customers in many different industries. Illustrated on these first two pages are typical examples of Starrett special toolmaking. The following pages show special function tools that we make as regular items because they are commonly used in industry.

Special toolmaking activities are coordinated under the direction of special order sales engineers who oversee each order from the time it is entered until shipment is made. Complete manufacturing facilities and engineering counsel are available.

Customers are invited to submit drawings and specifications for prompt quotation. Please direct these to the attention of:

The L.S. Starrett Company
 Special Order Department
 121 Crescent Street
 Athol, MA 01331-1915



MUL-T-ANVIL MICROMETERS

220 MUL-T-ANVIL MICROMETERS

0-2"/0-50MM

This tool was a new development in micrometer design and patent is held by Starrett. This micrometer will handle a wide variety of measurements impossible to obtain with regular micrometers, such as measuring the wall thickness of tubing, cylindrical walls from a hole or slot to an edge, many hard-to-reach locations, and the thickness of screw heads, shoulder lengths, etc.

This micrometer can be furnished with .0001" graduations, but we recommend .001" or 0.01mm for easier and more accurate readings. The Starrett Company, with our years of experience, recommends this because the anvils on this type of tool are not backed up by a frame as in a regular micrometer and could bend slightly.

220 Mul-T-Anvil Micrometers with Round and Flat Anvils and Carbide Faced Spindle

Ratchet Stop, Lock Nut		Friction Thimble, Lock Nut		Range	Graduation
Cat. No.	EDP	Cat. No.	EDP		
220XRL-1	66430	220XFL-1	50746	0-1"	.001"
220MXRL-25	65050			0-25mm	0.01mm
220ZZ-1	55209			Deluxe Case Only	

220M Mul-T-Anvil Micrometers With Round and Flat Anvils, Carbide Faced Spindle and 234B-1" or 234MB-25mm End Measuring Rod or Standard

Ratchet Stop, Lock Nut		Friction Thimble, Lock Nut		Range	Graduation
Cat. No.	EDP	Cat. No.	EDP		
220XRL-2	66432	220XFL-2	66433	1-2"	.001"
220MXRL-50	66434			25-50mm	0.01mm
220ZZ-2	55210			Deluxe Case Only	

V-Anvil only: Order PT13017, EDP 71399
 1" and 25mm models sent in fitted case.
 2" and 50mm models packed one in a box without case.

READABILITY FEATURES

- Starrett satin chrome finish – no glare – resists rust
- Advanced sleeve design with staggered lines and distinct figures for precise and easy readability
- Quick-reading figures – every thousandth numbered on inch tools

EASE-OF-HANDLING FEATURES

- Balanced frame and thimble design ensure easy handling, better readability
- Ring-type knurled lock nut for quick and sure locking
- A choice of friction thimble or combination ratchet/speeder for uniform pressure
- Interchangeable anvils are rigidly held in the vise type frame and quickly interchanged by a single lock screw adjustment
- Two hardened anvils furnished – round anvil approximately .120" diameter (3mm) and flat anvil approximately .125" (3mm) and .060" (1.5mm) thick
- "V" Anvil for measuring thickness of screw heads and shoulder lengths available separately
- Accommodates special anvils up to 5/16" (8mm) thick
- Can be used as a height gage by removing the vise jaw

ACCURACY AND LONG-LIFE FEATURES

- Rigid one-piece frame of drop forged steel
- Extremely hard and stable one-piece spindle (the heart of our accuracy)
- Quick and easy adjustment
- Tool is accurate to $\pm .0002"$ or $\pm 0.004\text{mm}$



220XRL-2



MUL-T-ANVIL MICROMETERS

790 ELECTRONIC MULTI-ANVIL MICROMETERS (WITH OUTPUT)

0-1"/0-25MM

Same as our 220 Micrometer with electronic readout.

790 Electronic Multi-Anvil Micrometers with Standard Inch Graduations on Shell and Thimble with Round and Flat Anvils

Cat. No.	EDP	Description
790AFL-1	64048	0-1"/0-25mm Range

790M Electronic Multi-Anvil Micrometers with Standard Millimeter Graduations on Shell and Thimble with Round and Flat Anvils

Cat. No.	EDP	Description
790MEAFL-25	66071	0-25mm/0-1" Range

Cable Information

Cat. No.	EDP	Description
733SCKB	69888	USB cable to PC (In focused window)
733SCU	69898	USB cable to computer running SPC Data Collection Software
733SCM	69893	Connection to Multiplexer (7612, 7613 or RMS 2704)
PT61963	66636	Computer Interface Cable Complete to PC (RS232C)
PT61120	65446	One 3-Volt Battery CR2450



790AFL

READABILITY FEATURES

- Large LCD digital readout is easy to read and reduces errors
- Resolution – .00005" and 0.001mm
- Conventional inch or millimeter graduations standard
- Attractive no-glare black wrinkle finish on the frame
- Starrett no-glare satin chrome finish on thimble and sleeve

ACCURACY AND LONG-LIFE FEATURES

- One 3-volt battery furnished for over a year of normal usage
- Automatic OFF after 30 minutes of nonuse
- Tool is accurate to $\pm .0002"$ or $\pm 0.004\text{mm}$

FULL-FUNCTION ACTION FEATURES

- Instant inch/millimeter conversion
- "ME" millimeter model will turn on in the millimeter mode after installation of a new battery
- Measurement HOLD button
- Ability to zero tool at any position
- Ability to retain and return to the true zero reading of the micrometer
- PRESET button to install any reading at any position
- Ability to install minimum and maximum limits
- Output data to Starrett SPC Plus hardware and software and to PCs
- Works well with Starrett DataSure® Wireless Data Collection Systems



SHEET METAL MICROMETERS

222 SHEET METAL MICROMETERS

0-1"/0-25MM

These micrometers reach over the edge of sheet metal and take measurements away from the edge toward the center. Also for other gaging jobs where a deep throat micrometer is needed. Rounded anvil on 1" (25mm) size gives a point contact for more accurate gaging; flat anvil is also available. The 1/2" and 13mm micrometers have satin chrome frames; 1" and 25mm micrometer frames have black wrinkle finish.

222 Sheet Metal Micrometers, 2" Throat Depth (0-1/2" Range)			
Cat. No.	EDP	Anvil	Graduation
222RL-1/2	50756	Flat	.001"
222XRL-1/2	50757	Flat	.001"
222 Sheet Metal Micrometers, 6" Throat Depth (0-1" Range)			
Cat. No.	EDP	Anvil	Graduation
222AXR-1	50762	Rounded	.001"
222BXR-1	50763	Flat	.001"
222M Sheet Metal Micrometers, 50mm Throat Depth (0-13mm Range)			
Cat. No.	EDP	Anvil	Graduation
222MRL-13	50758	Flat	0.01mm
222M Sheet Metal Micrometers, 150mm Throat Depth (0-25mm Range)			
Cat. No.	EDP	Anvil	Graduation
222MAXR-25	66435	Rounded	0.01mm
222MBXR-25	66436	Flat	0.01mm
Case for 222 and 222M Sheet Metal Micrometers			
Cat. No.	EDP	Description	
222ZZ-1	55212	Case for 222 Micrometers	

0-1" range and 0-25mm range micrometers sent with rounded anvil unless otherwise ordered. Packed one in a box without case.

READABILITY FEATURES

- Starrett satin chrome finish – no glare – resists rust
- Advanced sleeve design with staggered lines and distinct figures for precise and easy readability
- Convenient decimal equivalents on Inch tools

EASE-OF-HANDLING FEATURES

- Balanced frame and thimble design ensure easy handling and better readability
- Combination ratchet and speeder for uniform pressure and quicker adjustment
- Ring-type knurled lock nut for quick and sure locking (on 1/2" and 13mm range models)

ACCURACY AND LONG-LIFE FEATURES

- Rigid one-piece frame of drop forged steel, ribbed for strength and stability
- Extremely hard and stable one-piece spindle (the heart of our accuracy)
- Quick and easy adjustment

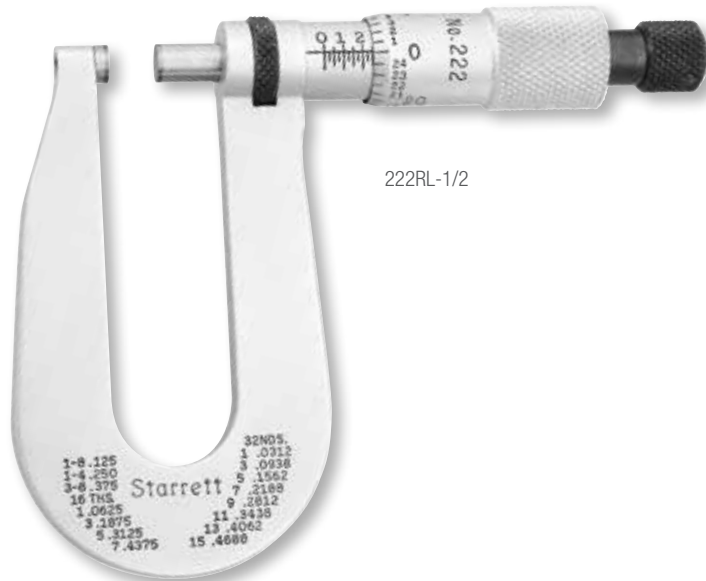

SHEET METAL MICROMETERS

764 ELECTRONIC SHEET METAL MICROMETERS (WITH OUTPUT)

0-1"/0-25MM

This micrometer is the same as our 222 Micrometer, except that it has an electronic readout and is available in the 1" (25mm) and 25mm ranges. Rounded anvil gives a point contact for more accurate gaging; flat anvil also available.

764 Electronic Sheet Metal Micrometers, 6" Throat Depth with Standard Inch Graduations on Shell and Thimble

Cat. No.	EDP	Description
764AXFL	66445	0-1"/0-25mm Range, Round Anvil
764BXFL	66525	0-1"/0-25mm Range, Flat Anvil

764M Electronic Sheet Metal Micrometers, 150mm Throat Depth with Standard Millimeter Graduations on Shell and Thimble

Cat. No.	EDP	Description
764MEAXFL	66446	0-25mm/0-1" Range, Round Anvil

Cable Information for 764 and 764M Electronic Sheet Metal Micrometers

Part No.	EDP	Description
PT61963	66636	Computer Interface Cable Complete to PC (RS232C)
733SCKB	69888	USB cable to PC (In focused window)
733SCU	69898	USB cable to computer running SPC Data Collection Software
733SCM	69893	Connection to Multiplexer (7612, 7613 or RMS 2704)
PT61120	65446	One 3-Volt Battery CR2450

Packed one in a box without case.



764AXFL

READABILITY FEATURES

- Large, right-sized, high-contrast LCD digital readout is easy to read and reduces errors
- Resolution: .00005" and 0.001mm
- Conventional inch or millimeter graduations standard
- Attractive no-glare black wrinkle finish on the frame
- Starrett no-glare satin chrome finish on thimble and sleeve

ACCURACY AND LONG-LIFE FEATURES

- One 3-volt battery furnished for over a year of normal usage
- Automatic OFF after 30 minutes of nonuse

FULL-FUNCTION ACTION FEATURES

- Instant inch/millimeter conversion
- "ME" millimeter model will turn on in the millimeter mode after installation of a new battery
- Measurement HOLD button
- Ability to zero tool at any position
- Ability to retain and return to the true zero reading of the micrometer
- PRESET button to install any reading at any position
- Ability to install minimum and maximum limits
- RS232 data output port
- Works well with Starrett DataSure® Wireless Data Collection Systems

TUBE MICROMETERS

569 TUBE MICROMETERS

0-1"/0-25MM

For measuring the wall thickness of tubing and other parts with cylindrical walls. Also for measuring from a hole to an edge (note minimum hole sizes in table). Rigid steel "half" frame with smooth black enamel finish. Anvil diameter = 0.185".

READABILITY FEATURES

- Starrett satin chrome finish – no glare – resists rust
- Advanced sleeve design with staggered lines and distinct figures for precise and easy readability
- Convenient decimal equivalents on inch tools

EASE-OF-HANDLING FEATURES

- Balanced frame and thimble design ensure easy handling and better readability

ACCURACY AND LONG-LIFE FEATURES

- Rigid steel frame ribbed for strength and stability
- Extremely hard and stable one-piece spindle (the heart of our accuracy)
- Quick and easy adjustment

569 Tube Micrometers (0-1" Range)				
Cat. No.	EDP	Graduation	Minimum Hole Size	Description
569AXP	66437	.001"	3/16"	Carbide Faced Spindle
569BXP	66439		3/8"	Carbide Faced Spindle
569M Tube Micrometers (0-25mm Range)				
Cat. No.	EDP	Graduation	Minimum Hole Size	Description
569MAXP	66438	0.01mm	4.8mm	Carbide Faced Spindle
569MBXP	66440		9.5mm	Carbide Faced Spindle
Deluxe Case for 569 and 569M Tube Micrometers				
Cat. No.	EDP	Description		
910	55397	Deluxe case only for the 569		

Special anvils also can be furnished, priced on application. Sent in fitted case.



569AXP

769 ELECTRONIC TUBE MICROMETERS (WITH OUTPUT)

0-1"/0-25MM

This micrometer is the same as our 569 with an electronic readout and the following additional features and benefits:

READABILITY FEATURES

- Large LCD digital readout is easy to read and reduces errors
- Resolution: .00005" and 0.001mm
- Conventional inch or millimeter graduations standard
- Attractive no-glare black wrinkle finish on the frame
- Starrett no-glare satin chrome finish on thimble and sleeve

ACCURACY AND LONG-LIFE FEATURES

- One 3-volt battery furnished for over a year of normal usage
- Automatic OFF after 30 minutes of nonuse

FULL-FUNCTION ACTION FEATURES

- Instant inch/millimeter conversion
- "ME" model turns on in millimeter mode after battery installation
- Measurement HOLD button
- Ability to zero tool at any position
- Ability to retain and return to the true zero reading of the micrometer
- PRESET button to install any reading at any position
- Ability to install minimum and maximum limits
- RS232 data output port
- Works well with Starrett DataSure® Wireless Data Collection Systems

769 Electronic Tube Micrometers, Standard Inch Graduations		
Cat. No.	EDP	Description
769AXFL	66447	0-1"/0-25mm Range, Carbide Faced Spindle
769 Electronic Tube Micrometers, Standard Millimeter Graduations		
Cat. No.	EDP	Description
769MEAXFL	66448	0-25mm/0-1" Range, Carbide Faced Spindle
Cable Information for 769 Electronic Tube Micrometers		
Part No.	EDP	Description
PT61963	66636	Computer Interface Cable Complete to PC (RS232C)
733SCKB	69888	USB cable to PC (In focused window)
733SCU	69898	USB cable to computer running SPC Data Collection Software
733SCM	69893	Connection to Multiplexer (7612, 7613 or RMS 2704)
PT61120	65446	One 3-Volt Battery CR2450



769MEAXFL



CRANKSHAFT MICROMETERS

436 AUTOMOTIVE MICROMETERS

1-1/2– 3-1/2"/38-88MM

This micrometer is designed for automotive work and especially for crankshaft measuring. It is also well suited for all other work within its capacity. It measures the diameter of the journal bearing and main bearing of most crankshafts since the micrometer has a range from 1-1/2" (38mm) – 3-1/2" (88mm).

436-3 1/2 Automotive Crankshaft Micrometers (1-1/2 – 3-1/2" Range)

Cat. No.	EDP	Graduation
T436RLS-3 1/2	65493	.0001"

436M-88 Automotive Crankshaft Micrometers (38-88mm Range)

Cat. No.	EDP	Graduation
V436MRLS-88	65600	0.002mm

Case for 436-3 1/2 and 436M-88 Automotive Crankshaft Micrometers

Cat. No.	EDP	Description
733ZZ-4	66139	Protective Case

Carbide measuring faces available on special order. Specify "X" after catalog number.



T436RLS-3 1/2

READABILITY FEATURES

- Starrett satin chrome finish – no glare – resists rust
- Advanced sleeve design with staggered lines and distinct figures for precise and easy readability
- Quick-reading figures – every thousandth numbered on inch tools
- The reading point is on the under side of the sleeve, plainly visible while measuring. It's a very useful feature when measuring between webs.

EASE-OF-HANDLING FEATURES

- Balanced frame and thimble design ensure easy handling and better readability
- Ring-type knurled lock nut for quick and sure locking
- Combination ratchet and speeder for uniform pressure and quicker adjustment
- Gracefully designed tapered frame for use in narrow slots and tight places
- 2" (50mm) range
- 2-5/8" (66mm) throat depth

ACCURACY AND LONG-LIFE FEATURES

- Rigid one-piece frame of drop forged steel, ribbed for extra strength
- Extremely hard and stable one-piece spindle (the heart of our accuracy)
- Appropriate standard included

MICROMETERS

458 AUTOMOTIVE DISC BRAKE MICROMETERS

.300-2"/7.6-50MM

- Measures depth of wear grooves in disc of brake systems
- 3" (75mm) frame with a 3-1/2" (88mm) depth to allow additional reach
- Flat carbide spindle and a carbide anvil with a 60° point

READABILITY FEATURES

- Starrett satin chrome finish – no glare – resists rust
- Advanced sleeve design for precise, easy readability
- Quick-reading figures – every thousandth numbered on inch tools

EASE-OF-HANDLING FEATURES

- Balanced frame and thimble design ensure easy handling and better readability
- Combination ratchet and speeder for uniform pressure and quicker adjustment
- Gracefully designed tapered frame for use in narrow slots and tight places
- 3-1/2" (88mm) throat depth

ACCURACY AND LONG-LIFE FEATURES

- Rigid one-piece steel frame
- Extremely hard and stable one-piece spindle (the heart of our accuracy)
- Carbide measuring face on the spindle and carbide "V" anvil
- Quick and easy adjustment

260 GROOVE MICROMETERS

INCH/MM

Quickly and easily measures widths of internal or external grooves and lands.

READABILITY FEATURES

- Starrett satin chrome finish – no glare – resists rust
- Advanced sleeve design with staggered lines and distinct figures for precise and easy readability
- Quick-reading figures – every thousandth numbered on inch tools

EASE-OF-HANDLING FEATURES

- Balanced design to ensure easy handling and better readability
- Has a reach of 1-5/8" (41mm) maximum hole depth
- Each measuring disc is 9/32" (7mm) diameter and .025" (0.63mm) thick
- Will measure groove widths .050-1.050" (1.27-26.6mm)
- Will measure land widths from 0-1" and 0-25mm

ACCURACY AND LONG-LIFE FEATURES

- Extremely hard and stable one-piece spindle (the heart of our accuracy)
- Hardened, ground, and lapped measuring discs
- Quick and easy adjustment
- This tool is accurate to $\pm .0004"$ or $\pm 0.01\text{mm}$

.300-2" Range			
Cat. No.	EDP	Range	Graduation
458AXR	67534	.300-1.300"	.001"
458AXRS*	67535		
458BXR	67536	1-2"	.001"
458BXRS*	67537		

7.6-50mm Range			
Cat. No.	EDP	Range	Graduation
458MAXR	67538	7.6-33mm	0.01mm
458MAXRS**	67539		
458MBXR	67540	25-50mm	0.01mm
458MBXRS**	67541		

*With 26852-0 Gage Block Standard.

**With 26853-0 Gage Block Standard.



260 and 260M Groove Micrometer					
Cat. No.	EDP	Graduation	Range	Land Widths	Max. Hole Depth
260Z	67987	.001"	.050"-1.050"	0-1.000"	1-5/8"
260MZ	67988	0.01mm	1.27-26.27mm	0-25mm	41mm

*Add .050" to 260Z (1.27mm to 260MZ) micrometer reading.

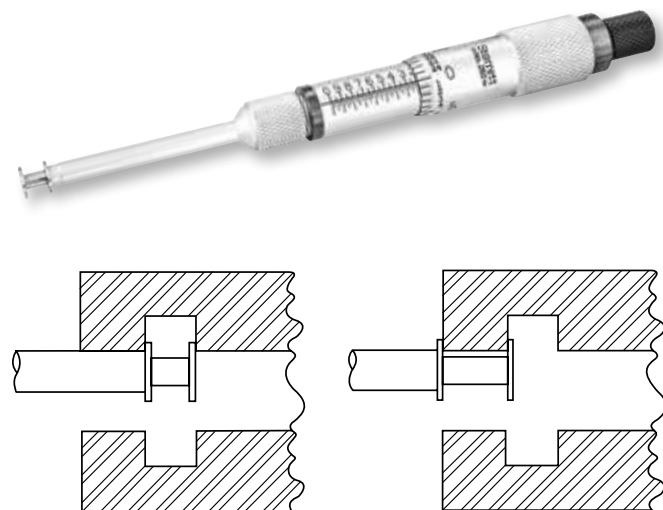

PAPER THICKNESS MICROMETERS

223 PAPER GAGE MICROMETERS

0-11/32"/0-8.75MM

This micrometer is designed for use in paper mills, printing shops, paper warehouses, rubber plants, etc. for accurately, quickly measuring the thickness of paper, cardboard, chipboard, rubber, plastics, and other similar products, up to 11/32" (8.75mm).

223 and 223M Paper Gage Micrometers (0-11/32"/0-8.75mm Range)

Cat. No.	EDP	Graduation
223RL	50768	.001"
223MRL	64336	0.01mm

Case for 223 Paper Gage Micrometers

Cat. No.	EDP	Description
921	55213	Protective Case

READABILITY FEATURES

- Starrett satin chrome finish – no glare – resists rust
- Advanced sleeve design with staggered lines and distinct figures for precise and easy readability
- Convenient decimal equivalents on inch tool

EASE-OF-HANDLING FEATURES

- Balanced frame and thimble design ensure easy handling and readability
- Ring-type knurled lock nut for quick and sure locking
- Combination ratchet and speeder for uniform pressure and quick adjustment
- Anvil and spindle faces are 7/16" (11mm) diameter to prevent compressing the material being measured and to ensure accurate readings
- The floating anvil automatically adjusts itself to any surface condition
- Convenient finger-holding ring is also provided

ACCURACY AND LONG-LIFE FEATURES

- Rigid one-piece frame of drop forged steel
- Extremely hard and stable one-piece spindle (the heart of our accuracy)
- Quick and easy adjustment



223RL

BLADE MICROMETERS

486 BLADE TYPE MICROMETERS WITH NON-ROTATING SPINDLE

0-12"/0-150MM

Here is another special function Starrett micrometer. It is designed for fast and accurate measurements of circular form tools, diameter and depth of narrow grooves, slots, keyways, recesses, and depths between lands and fins.

486 Blade Type Micrometers (0-12" Range)			
Cat. No.	EDP	Range	Graduation
486P-1	52499	0-1"	.001"
486P-2	52501	1-2"	
486P-3	52503	2-3"	
486P-4	52505	3-4"	
486P-5	52507	4-5"	
486P-6	52509	5-6"	
486P-7	67094	6-7"	
486P-8	67095	7-8"	
486P-9	67096	8-9"	
486P-10	67097	9-10"	
486P-11	67098	10-11"	
486P-12	67099	11-12"	
486M Blade Type Micrometers (0-150mm Range)			
Cat. No.	EDP	Range	Graduation
486MP-25	64257	0-25mm	0.01mm
486MP-50	64258	25-50mm	
486MP-75	64259	50-75mm	
486MP-100	64260	75-100mm	
486MP-125	64261	100-125mm	
486MP-150	64262	125-150mm	

READABILITY FEATURES

- Starrett satin chrome finish – no glare – resists rust
- Advanced sleeve design with staggered lines and distinct figures for precise and easy readability

EASE-OF-HANDLING FEATURES

- Speeder for quicker adjustment on all sizes
- Non-rotating spindle prevents blade from turning in narrow slots or rolling off shoulder
- The blades are .030" (0.8mm) thick
- Blades will measure to 5/16" (8mm) depths

ACCURACY AND LONG-LIFE FEATURES

- Rigid steel frame ribbed for extra strength on sizes through 6" (150mm)
- Extremely hard and stable one-piece spindle (the heart of our accuracy)
- Quick and easy adjustment

Cases for 486 and 486M Blade Type Micrometers		
Cat. No.	EDP	Range
913	55400	1", 25mm
922	55222	2", 50mm
952	55223	3", 75mm
953	55224	4", 100mm
954	55225	5", 125mm
930	55276	6", 150mm
931	55277	7", 175mm
932	55278	8", 200mm
933	55279	9", 225mm
934	55280	10", 250mm
935	55281	11", 275mm
436ZZ-13	55282	12", 300mm

MICROMETERS



BLADE MICROMETERS

786 ELECTRONIC MICROMETERS WITH NON-ROTATING SPINDLE (WITH OUTPUT)

0-5"/0-125MM

This micrometer is the same as our 486 with electronic readout and the following additional features:

786 Electronic Blade-Type Micrometers with Standard Inch Graduations on Shell and Thimble

Cat. No.	EDP	Range		Resolution	
		in	Approx. mm	in	mm
786P-1	65225	0-1	0-25.4		
786P-2	65226	1-2	25.4-51		
786P-3	65227	2-3	51-76	.00005"	0.001mm
786P-4	65228	3-4	76-101		
786P-5	65229	4-5	101-127	.0001"	0.001mm

786 Electronic Blade-Type Micrometers with Standard Millimeter Graduations on Shell and Thimble

Cat. No.	EDP	Range		Resolution	
		mm	Approx. in	mm	in
786MEP-25	66118	0 - 25mm	0-.984"		
786MEP-50	66126	25 - 50mm	.984-1.968"		
786MEP-75	66127	50 - 75mm	1.968-2.950"	0.001mm	.00005"
786MEP-100	66128	75 - 100mm	2.950-3.930"		
786MEP-125	66129	100 - 125mm	3.930-4.920"		

Cable Information for 786 Electronic Blade-Type Micrometers

Part No.	EDP	Description
733SCKB	69888	USB cable to PC (In focused window)
733SCU	69898	USB cable to computer running SPC Data Collection Software
733SCM	69893	Connection to Multiplexer (7612, 7613 or RMS 2704)
PT61963	66636	Computer Interface Cable Complete to PC (RS232C)
PT61120	65446	One 3-Volt Battery CR2450

Attractive, protective case available by ordering 733ZZ and one size larger than the micrometer. Example: For 786P-2, order 733ZZ-3.

READABILITY FEATURES

- Large LCD digital readout is easy to read and reduces errors
- Conventional inch or millimeter graduations standard
- Attractive no-glare black wrinkle finish on the frame
- Starrett no-glare satin chrome finish on thimble and sleeve

ACCURACY AND LONG-LIFE FEATURES

- One 3-volt battery furnished for over a year of normal usage
- Automatic OFF after 30 minutes of nonuse

FULL-FUNCTION ACTION FEATURES

- Instant inch/millimeter conversion
- "ME" millimeter models will turn on in the millimeter mode after installation of a new battery
- Measurement HOLD button
- Ability to zero tool at any position
- Ability to retain and return to the true zero reading of the micrometer
- PRESET button to install any reading at any position
- Ability to install minimum and maximum limits
- RS232 data output port
- Works well with Starrett DataSure® Wireless Data Collection Systems



786P-2



DISC-TYPE MICROMETERS

256 WITH ROTATING OR NON-ROTATING SPINDLES

0-3"/0-75MM

These tools are used to measure the thickness of work sections such as ribs, lands, fins, cutting edges on form tools, and chordal thickness of gear teeth. Because of their large anvil and spindle faces, the 1" and 25mm sizes are also useful for measuring the thickness of sheet materials like paper, cardboard, rubber, and plastics.

256 Disc-Type Micrometers (.001" Graduation)		
Cat. No.	EDP	Range
256RL-1	51236	0-1"
256PN-1	56469	0-1"
256RL-2	55940	1-2"
256RL-3	55941	2-3"
256M Disc-Type Micrometers (0.01mm Graduation)		
Cat. No.	EDP	Range
256MRL-25	51238	0-25mm
256MPN-25	56470	0-25mm
256MRL-50	55942	25-50mm
256MRL-75	55943	50-75mm
Cases for 256 and 256M Disc-Type Micrometers		
Cat. No.	EDP	Description
910	55397	Deluxe case for 1" and 25mm micrometers
912	55399	Deluxe case for 2" and 50mm micrometers
922	55222	Deluxe case for 3" and 75mm micrometers

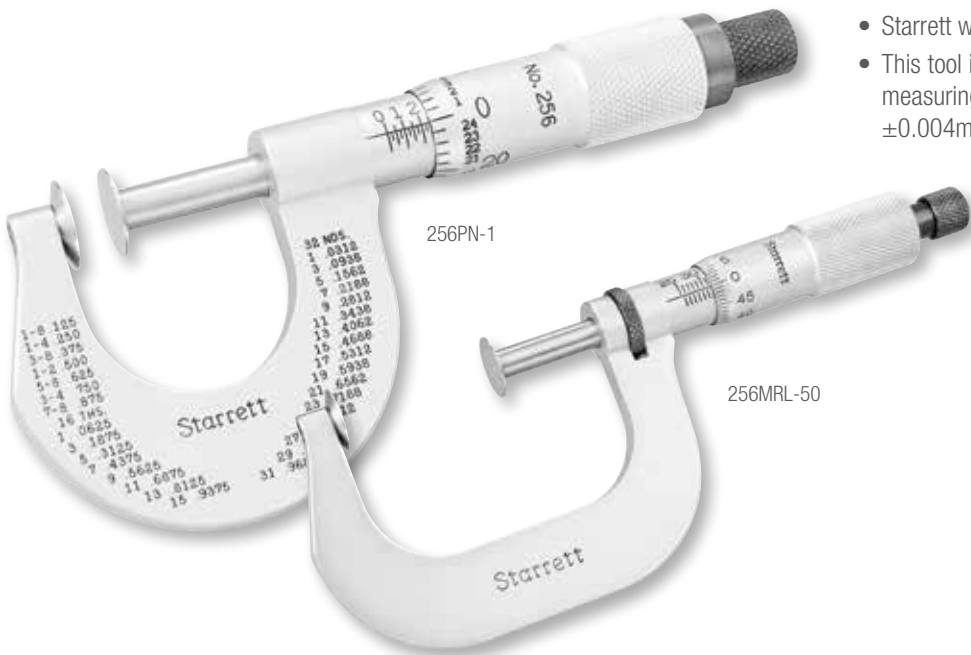

READABILITY FEATURES

- Starrett satin chrome finish – no glare – resists rust
- Advanced sleeve design with staggered lines and distinct figures for precise and easy readability
- Quick-reading figures – every thousandth numbered on inch tools
- Convenient decimal equivalents on 1" and 2" reading tools

EASE-OF-HANDLING FEATURES

- Balanced frame and thimble design ensure easy handling and better readability
- Ring-type knurled lock nut for quick and sure locking
- The combination ratchet and speeder for uniform pressure and quicker adjustment on all sizes
- Gracefully designed tapered frame for use in narrow slots and tight places
- Anvil and spindle discs are 1/2" (12.7mm) diameter tapering to .015" (0.4mm) edge thickness making it possible to enter narrow grooves and recesses
- Available in the 1" and 25mm sizes with rotating or non-rotating spindle

ACCURACY AND LONG-LIFE FEATURES

- Rigid one-piece frame of drop forged steel
- Extremely hard and stable one-piece spindle (the heart of our accuracy)
- Quick and easy adjustment
- Starrett workmanship
- This tool is accurate to $\pm 0.00015"$ or $\pm 0.003mm$ measuring over the whole surface and $\pm 0.0002"$ or $\pm 0.004mm$ measuring on the edges



DISC-TYPE MICROMETERS

756 ELECTRONIC DISC-TYPE MICROMETER WITH ROTATING SPINDLE (WITH OUTPUT)

0-1"/0-25MM

The same as our 256 with an electronic readout and the following additional features and benefits:

756 Electronic Disc-Type Micrometer

Cat. No.	EDP	Description
756FL-1	64042	0-1"/0-25mm range, with standard inch graduations on shell and thimble

756M Electronic Disc-Type Micrometer

Cat. No.	EDP	Description
756MEFL-25	66134	0-25mm/0-1" range, with standard millimeter graduations on shell and thimble

Cable Information for 756 and 756M Electronic Disc-Type Micrometers

Part No.	EDP	Description
733SCKB	69888	USB cable to PC (In focused window)
733SCU	69898	USB cable to computer running SPC Data Collection Software
733SCM	69893	Connection to Multiplexer (7612, 7613 or RMS 2704)
PT61963	66636	Computer Interface Cable Complete to PC (RS232C)
PT61120	65446	One 3-Volt Battery CR2450

Case for 756 and 756M Electronic Disc-Type Micrometers

Cat. No.	EDP	Description
949	63874	Protective case



756FL-1

READABILITY FEATURES

- Large, right-sized, high-contrast LCD digital readout is easy to read and reduces errors
- Resolution: .00005" and 0.001mm
- Conventional inch or millimeter graduations standard
- Attractive no-glare black wrinkle finish on the frame
- Starrett no-glare satin chrome finish on thimble and sleeve

ACCURACY AND LONG-LIFE FEATURES

- One 3-volt battery furnished for dependable power and over one year's normal usage
- Automatic OFF after 30 minutes of nonuse
- Anvil and spindle discs are 1/2" (12.7mm) diameter tapering to 0.15" (0.4mm) edge thickness making it possible to enter narrow grooves and recesses
- Tool is accurate to ± 0.00015 " or ± 0.003 mm measuring over the whole surface and ± 0.0002 " or ± 0.004 mm measuring on the edge

FULL-FUNCTION ACTION FEATURES

- Instant inch/millimeter conversion
- "ME" millimeter model will turn on in the millimeter mode after installation of a new battery
- Measurement HOLD button
- Ability to zero tool at any position
- Ability to retain and return to the true zero reading of the micrometer
- PRESET button to install any reading at any position
- Ability to install minimum and maximum limits
- RS232 data output port
- Works well with Starrett DataSure® Wireless Data Collection Systems

ROUNDED ANVIL MICROMETERS

576, 577, 211 MICROMETERS

0-1/2"/0-13MM; 0-1"/0-25MM

These three micrometers are all extremely useful for measuring the wall thickness of parts such as solid and split bearings, tubing, sleeves, collars, rings, various cylinders, and also measuring from the inside of a hole to an edge. All three have a rounded anvil which contacts the inside curved surface and a flat spindle for contacting the outside of the work, thus producing single point contact. This permits accurate gaging of curved surface thickness in thousandths of an inch or hundredths of a millimeter.

Rounded anvils are also available on the 222 Sheet Metal Micrometer or by special order.

576, 577 and 211 Micrometers (0-1" Range)			
Cat. No.	EDP	Range	Graduation
576XR	66441	0-1/2"	.001"
577XP	66443	0-1"	
211XP	66428	0-1"	
576M and 577M Micrometers (0-25mm Range)			
Cat. No.	EDP	Range	Graduation
576MXR	66442	0-13mm	0.01mm
577MXP	66444	0-25mm	
Cases for 576, 576M, 577, 577M and 211 Micrometers			
Cat. No.	EDP	Description	
910	55397	Attractive protective case for 211 and 577 Micrometers	
921	55213	Attractive protective case for 576 Micrometers	

Ball Attachment 247 used for rounded anvil effect is also available for other standard micrometers.

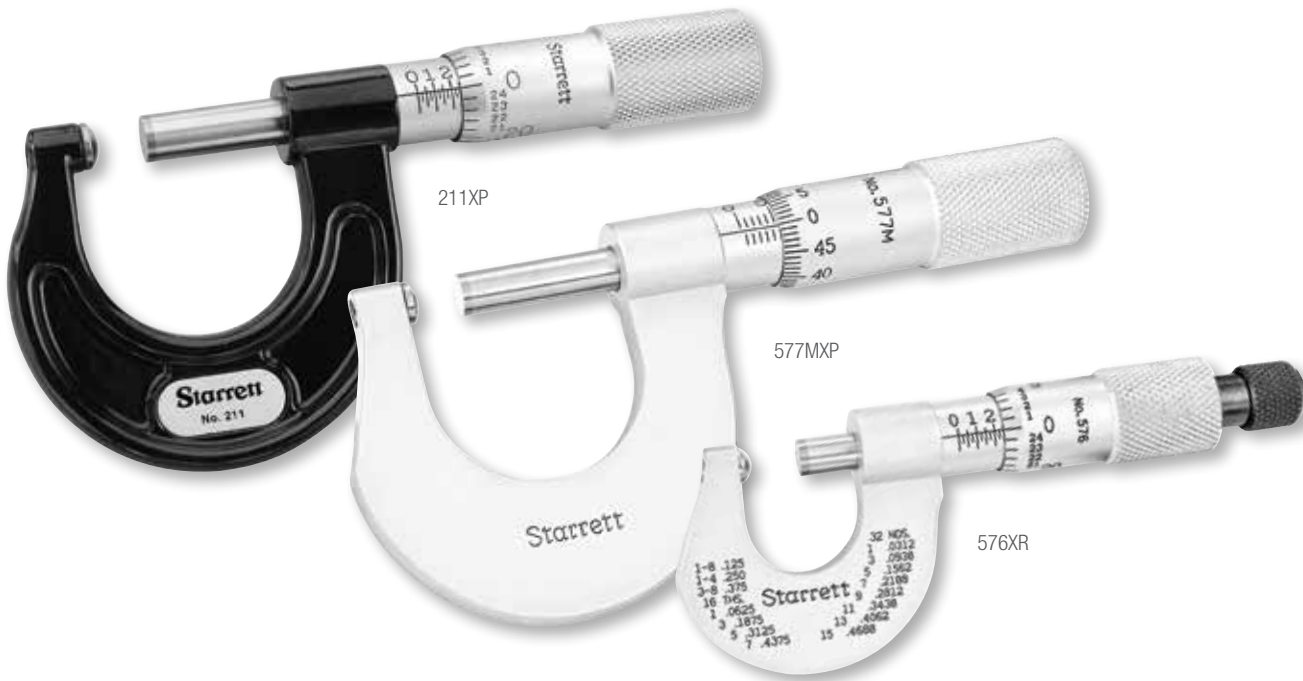

CAPACITY

- The 576 can get into holes as small as 5/16 of an inch (8mm) and measure up to 1/2 inch (13mm)
- The 577 can get into holes as small as 3/8 of an inch (9.5mm) and measure up to 1 inch (25mm)
- The 211 can get into holes as small as 5/8 of an inch (16mm) and measure up to 1 inch (25mm)

READABILITY FEATURES

- Starrett satin chrome finish – no glare – resists rust
- Advanced sleeve design with staggered lines and distinct figures for precise and easy readability
- Convenient decimal equivalents on inch tools

EASE-OF-HANDLING FEATURES

- Balanced frame and thimble design ensure easy handling and readability
- Gracefully designed tapered frame for narrow slots and tight places

ACCURACY AND LONG-LIFE FEATURES

- Rigid steel frames
- Extremely hard and stable one-piece spindle (the heart of our accuracy)
- Quick and easy adjustment



MICROMETERS

788 ELECTRONIC MICROMETERS WITH ROUNDED ANVIL (WITH OUTPUT)

0-1"/0-25MM

This micrometer is similar to our 211, except that it has an electronic readout and the following extra features and benefits:

788 and 788M Electronic Micrometers

Cat. No.	EDP	Description
788XFL	66449	0-1"/0-25mm range, with standard inch graduations on shell and thimble
788MEXFL	66450	0-25mm/0-1" range, with standard millimeter graduations on shell and thimble

Cable Information for 788 Electronic Micrometers

Part No.	EDP	Description
733SCKB	69888	USB cable to PC (In focused window)
733SCU	69898	USB cable to computer running SPC Data Collection Software
733SCM	69893	Connection to Multiplexer (7612, 7613 or RMS 2704)
PT61963	66636	Computer Interface Cable Complete to PC (RS232C)
PT61120	65446	One 3-Volt Battery CR2450

Case for 788 and 788M Electronic Micrometers

Cat. No.	EDP	Description
949	63874	Case for 788 Micrometers

READABILITY FEATURES

- Large, high-contrast LCD digital readout reduces errors
- Resolution: .00005" and 0.001mm
- Conventional inch or millimeter graduations standard
- Attractive no-glare black wrinkle finish on the frame
- Starrett no-glare satin chrome finish on thimble and sleeve

ACCURACY AND LONG-LIFE FEATURES

- One 3-volt battery furnished for dependable power and over one year's normal usage
- Automatic OFF after 30 minutes of nonuse

FULL-FUNCTION ACTION FEATURES

- Instant inch/millimeter conversion
- "ME" millimeter model will turn on in the millimeter mode after installation of a new battery
- Measurement HOLD button
- Ability to zero tool at any position
- Ability to retain and return to the true zero reading of the micrometer
- PRESET button to install any reading at any position
- Ability to install minimum and maximum limits
- RS232 data output port
- Works well with Starrett DataSure® Wireless Data Collection Systems



788XFL

MICROMETERS

205 STEEL MILL MICROMETER

0-1"

This micrometer is specially designed for gaging hot metal sheet in steel mills and has many features for safer, faster, and more accurate measurements. Micrometer has rugged construction throughout, and is attached to a convenient wooden handle, correctly shaped for a firm grip. Allows measurements to be made while the micrometer can be comfortably held at a safe distance from the hot metal.

READABILITY FEATURES

- Starrett satin chrome finish – no glare – resists rust
- Advanced sleeve design with staggered lines and distinct figures for precise and easy readability
- Quick-reading figures – every thousandth numbered on inch tools
- Convenient decimal equivalents on inch tools
- Extra long bevel on thimble with heavy cut graduations

EASE-OF-HANDLING FEATURES

- Both spindle and anvil are beveled to easily slide onto the work
- Large, reversible wing lock nut is easy to lock or release, even when wearing heavy gloves
- Rugged frame construction and heavy duty spindle of .270" diameter

ACCURACY AND LONG-LIFE FEATURES

- Rigid one-piece frame of drop forged steel
- Extremely hard and stable one-piece spindle (the heart of our accuracy)
- Quick and easy adjustment by either the anvil or by a simple sleeve adjustment

205 Steel Mill Micrometer				
Cat. No.	EDP	Range	Graduation	Description
205HL	50730	0-1"	.001"	Lock nut, with handle



247 MICROMETER BALL ATTACHMENTS

INCH/MM

Outside micrometers and micrometer heads having spindle sizes listed below can be instantly converted for measuring wall thickness of tubing, split and full bearings, sleeves and other parts with rounded surfaces by means of the 247 Ball Attachment.

FEATURES

- Easily applied by snapping on to end of either anvil or spindle, thus permitting two attachments to be used together
- Balls are hardened, measure .200" and 5mm in diameter, and move freely in the retainer, insuring positive contact with anvil and spindle
- The diameters, .200" or 5mm, of each ball used must be subtracted from the micrometer reading
- All metal construction

247 Micrometer Ball Attachments, .200" Diameter Balls

Cat. No.	EDP	Description
247A	51174	For 2, 226 (old style), 230 and 577 Micrometers and 263 Micrometer Heads, .235" diameter Anvil and Spindle
247B	51175	For 224A, 224AA and 436 Micrometers, .270" diameter anvil and spindle
247C	51176	For 232 Micrometers and 463 Micrometer Heads, .200" diameter anvil and spindle
247D	51177	For 216, 226 (new style), 231, 436.1, 733, 795, 796, 3732, 1212 and 1230 Micrometers, .250" diameter anvil and spindle
247E	51178	For 224B through J, 238, 239, 436 Micrometers and 663 Micrometer Heads, .300" diameter anvil and spindle

247M Micrometer Ball Attachments, 5mm Diameter Balls

Cat. No.	EDP	Description
247MA	51179	For 2M and 230M Micrometers and 263M Micrometer Heads, 6mm diameter anvil and spindle
247MB	51180	For 436M Micrometers, 6.8mm diameter anvil and spindle
247MD	56691	For 216M and 436.1M Micrometers, 6.35mm diameter anvil and spindle
247ME	56692	For 224MB through J, 238M, 436M Micrometers and 663M Micrometer Heads, 7.6mm diameter anvil and spindle



SCREW THREAD MICROMETERS

575, 585 MICROMETERS FOR MEASURING PITCH DIAMETER

0-1"/0-25MM; 1-2"/25-50MM

These micrometers have a pointed spindle and a double V-anvil, both shaped to contact the screw thread as shown in the drawing. The micrometer reading therefore gives the pitch diameter.*

575 and 585 Screw Thread Micrometers (.001" Graduation)

Cat. No.	EDP	Range, Threads Per inch	Capacity, Pitch Diameter
575AP	56159	7-9	0-1"
575BP	56160	10-13	
575CP	56161	14-18	
575DP	56162	20-24	
575EP	56163	28-30	
575FP	56164	32-40	
585AP	56165	4 1/2 - 6	1-2"
585BP	56166	7-9	
585CP	56167	10-13	
585DP	56168	14-18	
585EP	56169	20-24	
585FP	56170	28-30	

575M and 585M Screw Thread Micrometers (0.01mm Graduation)

Cat. No.	EDP	Range, Pitch in mm	Capacity, Pitch Diameter
575MAP	56321	3-4	0-25mm
575MBP	56322	2-2.5	
575MCP	56323	1.25-1.75	
575MDP	56324	0.75-1	
575MEP	56325	0.5-0.7	
575MFP	56326	0.35-0.45	
585MAP	56327	4.5-6	25-50mm
585MBP	56328	3-4	
585MCP	56329	2-2.5	
585MDP	56330	1.25-1.75	

Cases

Cat. No.	EDP	Description
910	55397	Attractive protective case for 575
912	55399	Attractive protective case for 585

Swivel anvil available on special order – also in capacities over 2" (50mm).

575 sent in fitted case.

585 packed one in a box without case.

READABILITY FEATURES

- Starrett satin chrome finish – no glare – resists rust
- Advanced sleeve design with staggered lines and distinct figures for precise and easy readability
- Decimal equivalents on inch tools

EASE-OF-HANDLING FEATURES

- Balanced frame and thimble design for easy handling and better readability
- Gracefully designed tapered frame for use in narrow slots and tight places
- Furnished with fixed (non-rotating) anvil, but swivel anvils available on special order
- Available in capacity over 2" or 50mm (special order)

ACCURACY AND LONG-LIFE FEATURES

- One-piece frame of drop forged steel
- Extremely hard and stable one-piece spindle (the heart of our accuracy)
- Quick and easy adjustment
- Design allows 50% to 75% contact with the thread to be measured, thereby insuring contact with the pitch diameter at all times
- Design also ensures against contact with the root area of the thread
- Tools are accurate to $\pm .0002"$ or 0.004mm

575 AND 585 – INCH

For measuring American Unified National series and Unified J series screw threads. 585 micrometers come with a one-inch standard at no extra cost.

575M AND 585M – METRIC

For measuring I.S.O. metric and MJ screw threads. 585M micrometers come with a 25mm standard at no extra cost.

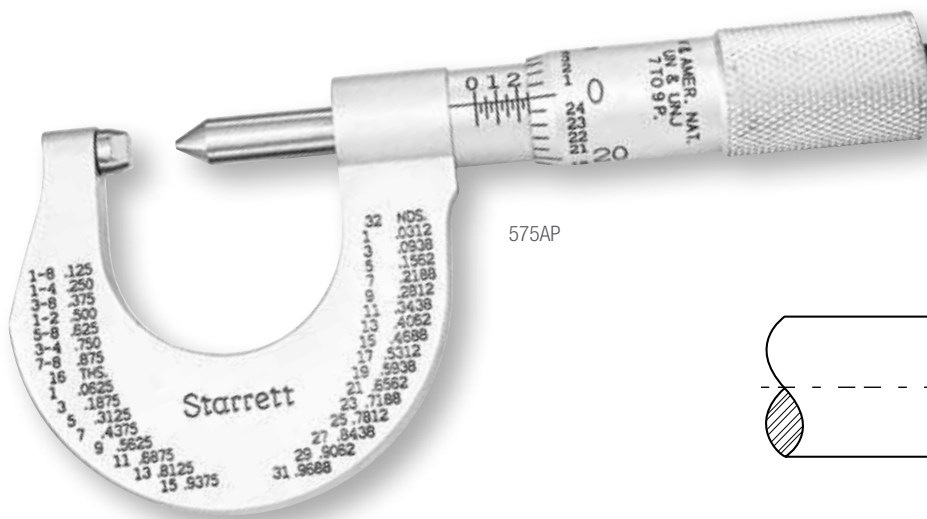

575AP

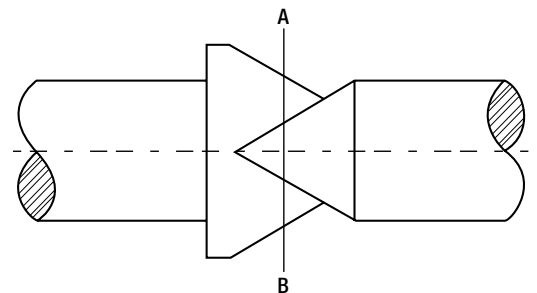

* MEASURING TIP: These tools are accurate for general purposes, especially if set to a thread plug gage of the size to be measured.

With the 575AP 0-1", pitch diameter is read directly in inches, since the line AB corresponds to the 0 reading.

POINT MICROMETERS

210 SCREW THREAD COMPARATOR MICROMETERS

0-7/8"/0-22MM

This micrometer is ideal for quick comparisons of thread accuracy in screw cutting operations, measuring in small grooves or recesses where regular micrometers cannot be used, and for many other applications.

NOTE: Does not measure pitch diameter. For such measurements, 575 or 585 Thread Micrometers are recommended.

READABILITY FEATURES

- Starrett satin chrome finish – no glare – resists rust
- Advanced sleeve design with staggered lines and distinct figures for precise and easy readability
- Convenient decimal equivalents on inch reading tools

EASE-OF-HANDLING FEATURES

- Balanced frame and thimble design ensure easy handling and better readability
- Gracefully designed tapered frame for narrow slots and tight places

ACCURACY AND LONG-LIFE FEATURES

- Rigid steel frame
- Extremely hard and stable one-piece spindle (the heart of our accuracy)
- The 210 has 60° conical anvil and spindle faces with 1/64" (0.4mm) flats on the ends of the points
- Quick and easy adjustment

760 ELECTRONIC SCREW THREAD COMPARATOR MICROMETER (WITH OUTPUT)

0-1"/0-25MM

Same features as our 210 with electronic readout and the following additional features and benefits:

READABILITY FEATURES

- Large LCD digital readout is easy to read and reduces errors
- Resolution: .00005" and 0.001mm
- Conventional inch or millimeter graduations standard
- Attractive no-glare black wrinkle finish on the frame
- Starrett no-glare satin chrome finish on thimble and sleeve

ACCURACY AND LONG-LIFE FEATURES

- One 3-volt battery furnished for over a year of normal usage
- Automatic OFF after 30 minutes of nonuse

FULL-FUNCTION ACTION FEATURES

- Instant inch/millimeter conversion
- "ME" millimeter model turns on in millimeter mode after battery installation
- Measurement HOLD button
- Zero tool at any position and return to true zero reading
- PRESET button to install any reading at any position
- Ability to install minimum and maximum limits
- RS232 data output port
- Works well with Starrett DataSure® Wireless Data Collection Systems

210 and 210M Screw Thread Comparator Micrometers (0-7/8" Range)

Cat. No.	EDP	Range	Graduation
210AP	50731	0-7/8"	.001"
210MAP	64334	0-22mm	0.01mm

Case for 210 and 210M Screw Thread Comparator Micrometers

Cat. No.	EDP	Description
910	55397	Attractive protective case

760 and 760M Electronic Screw Thread Comparator Micrometer

Cat. No.	EDP	Description
760FL	64051	0-1"/0-25mm range, standard inch graduations on shell and thimble
760MEFL	66135	0-25mm/0-1" range, standard millimeter graduations on shell and thimble

Case for 760 and 760M Electronic Screw Thread Comparator Micrometers

Cat. No.	EDP	Description
731ZZ-2	65163	Attractive protective case

Cable Information for 760 and 760M Electronic Screw Thread Comparator Micrometers

Part No.	EDP	Description
733SCKB	69888	USB cable to PC (In focused window)
733SCU	69898	USB cable to computer running SPC Data Collection Software
733SCM	69893	Connection to Multiplexer (7612, 7613 or RMS 2704)
PT61963	66636	Computer Interface Cable Complete to PC (RS232C)
PT61120	65446	One 3-Volt Battery CR2450



MICROMETERS

483, 485 V-ANVIL MICROMETERS

.093-2"/2-25MM | .078-1"

Used to check out-of-roundness from centerless grinding or other machining operations. Also used for measuring odd fluted taps, milling cutters, and reamers.

READABILITY FEATURES

- Direct measuring of three and five-fluted tools
- Starrett satin chrome finish – no glare – resists rust
- Advanced sleeve design for precise and easy readability
- Quick-reading figures – every thousandth numbered on inch tools

EASE-OF-HANDLING FEATURES

- Balanced frame and thimble design ensure easy handling and readability
- Ring-type knurled lock nut for quick and sure locking
- Combination ratchet and speeder for uniform pressure and quick adjustment

ACCURACY AND LONG-LIFE FEATURES

- Rigid one-piece frame of drop forged steel
- Extremely hard and stable one-piece spindle (the heart of our accuracy)
- Carbide facing on spindle and anvils for extra long wear
- Quick and easy adjustment

483, 483M and 485 V-Anvil Micrometers

Cat. No.	EDP	Range	Graduation	No. of Flutes it will Measure
T483XRL-1	52491	.093-1"	.0001"	3
T483XRL-2	52494	1-2"	.0001"	3
T485XRL	52497	.078-1"	.0001"	5
483MXRL-25	56046	2-25mm	0.01mm	3
485MXRL	56047			5

Cases for 483, 483M and 485 V-Anvil Micrometers

Cat. No.	EDP	Description
939	55331	Attractive protective case for 1" and 25mm sizes
483ZZ-2	55332	Attractive protective case for 2" size



225 WIRE MICROMETERS

0-.400"/0-10MM

This is another regularly offered special function Starrett micrometer designed to measure diameter of wire up to .400" (10mm).

READABILITY FEATURES

- Starrett satin chrome finish – no glare – resists rust
- Advanced sleeve design with staggered lines and distinct figures for precise and easy readability
- Quick-reading figures – every thousandth numbered on inch tools

EASE-OF-HANDLING FEATURES

- Smooth friction thimble for uniform pressure
- Hex body which stops the micrometer from rolling over when placed on a flat surface
- The throat is flat to support the wire when measuring
- The anvil and spindle extend below the flat surface

ACCURACY AND LONG-LIFE FEATURES

- Extremely hard and stable one-piece spindle (the heart of our accuracy)
- Quick and easy adjustment

225 Wire Micrometers (0-.400" Range)

Cat. No.	EDP	Graduation
T225F	50814	.0001"

225M Wire Micrometers (0-10mm Range)

Cat. No.	EDP	Graduation
V225MF	64255	0.001mm



T225F



MICROMETERS

207, 208 STAINLESS STEEL CAN SEAM MICROMETERS

207 and 208 Can Seam Micrometers are made of stainless steel and designed to measure the thickness and depth of can seams.

The 207 Micrometer is used to measure the seam at outside bottom edge of dome on top of aerosol cans. The 208 Micrometer is used to measure thickness of seam at top and bottom of flat-topped cans. The 208D Micrometer is used to measure thickness and depth of all standard can seams.

READABILITY FEATURES

- Satin finish stainless steel – no glare – rust and stain resistant
- Advanced sleeve design with staggered lines and distinct figures for precise and easy readability
- Quick-reading figures – every thousandth numbered on inch tools

EASE-OF-HANDLING FEATURES

- The 207 has a snub nose which permits measuring aerosol type cans

ACCURACY AND LONG-LIFE FEATURES

- Extremely hard and stable one-piece spindle (the heart of our accuracy)
- Quick and easy adjustment

207 and 208 Stainless Steel Can Seam Micrometers (0-.375" Range)			
Cat. No.	EDP	Graduation	Description
207Z	56173		Snub nose for aerosol cans
208Z	56175	.001"	Without depth gage
208DZ	56176		With depth gage (.200" range)
207M and 208M Stainless Steel Can Seam Micrometers (0-9.5mm Range)			
Cat. No.	EDP	Graduation	Description
207MZ	64337		Snub nose for aerosol cans
208MZ	64338	0.01mm	Without depth gage
208MDZ	63191		With depth fage (5mm range)

Depth range on 208D is .200". Depth range on 208MD is 5mm.

209 CAN CURL MICROMETERS

0-.500"/0-12.5MM

The 209 features a special rest foot and finger ring for consistent measurement of the curl thickness on aerosol cans with 1" (25mm) diameter domed tops.

READABILITY FEATURES

- Starrett satin chrome finish – no glare – resists rust
- Advanced sleeve design with staggered lines and distinct figures for precise and easy readability
- Quick-reading figures – every thousandth numbered on inch tools
- Convenient decimal equivalents on inch tools

EASE-OF-HANDLING FEATURES

- Balanced frame and thimble design ensure easy handling and better readability
- Ring-type knurled lock nut for quick and sure locking
- Combination ratchet and speeder for uniform pressure and quicker adjustment
- Finger ring for ease of measuring

ACCURACY AND LONG-LIFE FEATURES

- Special rest foot to locate the tool for higher repeatability
- Extremely hard and stable one-piece spindle (the heart of our accuracy)
- Quick and easy adjustment

209 Can Curl Micrometers (0-.500" Range)		
Cat. No.	EDP	Graduation
209RL	56473	.001"
209M Can Curl Micrometers (0-12.5mm Range)		
Cat. No.	EDP	Graduation
209MRL	64364	0.01mm

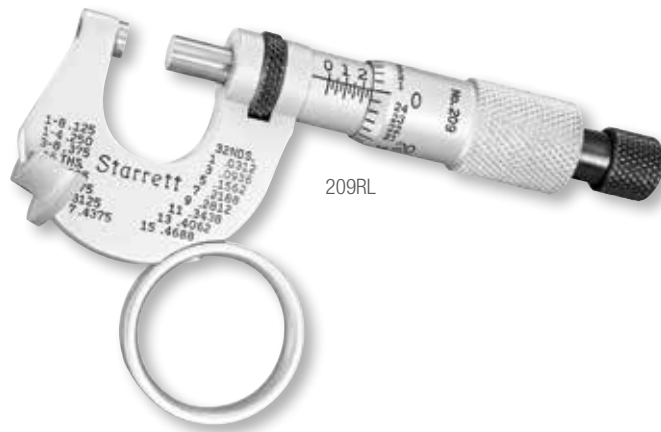

MICROMETERS

228 HUB MICROMETER

0-1"

The 228 Hub Micrometer is an ideal tool for precision measuring of hub thickness, for insertion through small holes to measure thickness, and for many other related uses. Micrometer has a specially designed shallow frame which makes it possible to easily pass through a 3/4" (19mm) hole.

228 Hub Micrometer (0-1" Range)		
Cat. No.	EDP	Graduation
228XRL	50921	.001"
Case		
Cat. No.	EDP	Description
228ZZ	55228	Deluxe case for 228 Hub Micrometer

READABILITY FEATURES

- Starrett satin chrome finish – no glare – resists rust
- Advanced sleeve design with staggered lines and distinct figures for precise and easy readability
- Quick-reading figures – every thousandth numbered on inch tools

EASE-OF-HANDLING FEATURES

- Balanced frame and thimble design ensure easy handling and better readability
- Ring-type knurled lock nut for quick and sure locking
- Combination ratchet and speeder for uniform pressure and quicker adjustment

ACCURACY AND LONG-LIFE FEATURES

- Rigid one-piece frame of drop forged steel
- Extremely hard and stable one-piece spindle (the heart of our accuracy)
- Quick and easy adjustment



228XRL

MICROMETER HEADS

The following pages show the full line of Starrett standard micrometer heads that have been designed and developed over the years working with the needs of our customers. The micrometer heads are invaluable for use on electronic equipment, machine tools, fixtures, special gaging and other equipment where precise movement and adjustment are required.

Dimensional specifications are available upon request.

Special features are described with each tool, but all of these tools have these features that benefit the user:

- Starrett satin chrome finish – no glare – resists rust on all reading surfaces
- Advanced sleeve design with staggered lines and distinct figures for precise and easy readability
- Quick-reading figures on all inch reading tools
- Extremely hard and stable one-piece spindle (the heart of our accuracy and long life)
- Micro-lapped measuring face for flatness and squareness
- Quick and easy adjustment

SPECIAL HEADS

In addition to standard micrometer heads, Starrett has also designed and manufactured many special types of micrometer heads for widely diversified applications requiring micrometer accuracy in settings and adjustments. These special heads are designed to exact specifications for specialized usage with wave meters and other equipment in the electronics industry, machine tools, fixtures, special gages, tools, and all special mountings. They can be furnished to suit your particular requirements in a wide choice of sizes, range and graduations.

We design and build to your special need, so if you don't see what you want, please ask for it.

For quotations or recommendations, write:
The L.S. Starrett Co.
Special Order Department
121 Crescent Street
Athol, MA 01331

MICROMETER HEADS

261L MICROMETER HEADS WITH NON-ROTATING SPINDLES

0-1/2"/0-13MM

Because the spindle does not rotate, these tools are useful in driving positioning tables directly without an intermediate connecting device. They are also useful in gaging jobs where scratches on the work surface cannot be tolerated or where there is risk of distortion when spindle meets work – as in measuring soft or elastic materials. Spindle wear is also reduced since there is no rotational friction as its face contacts the work.

- Ring-type lock nut for quick and sure locking at any setting
- A speeder for quicker adjustment – this is not a ratchet stop. The tool is dependent on your own "feel"

261L Micrometer Heads (0-1/2" Range)

Cat. No.	EDP	Graduation	Description
261L	55944	.001"	Speeder, lock nut

261ML Micrometer Heads (0-13mm Range)

Cat. No.	EDP	Graduation	Description
261ML*	64346	0.01mm	Specify clamping diameter (9.5mm or 10mm)

*9.5mm clamping diameter sent unless otherwise specified.



261L

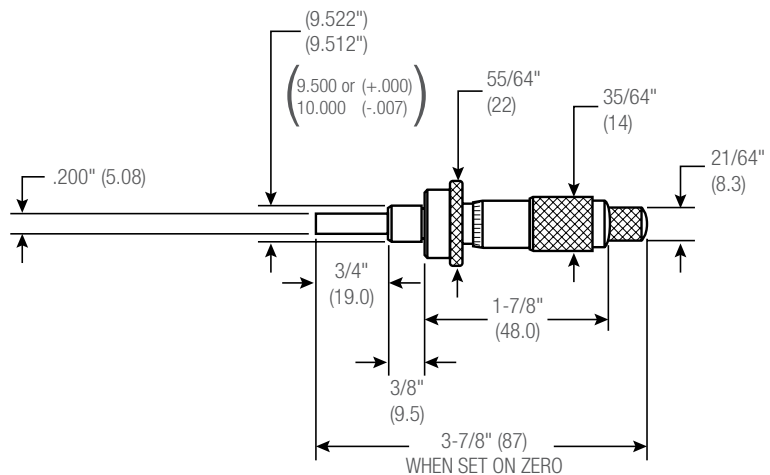

261L (0-1/2") and 261ML (0-13mm) dimensions



MICROMETER HEADS

262 MICROMETER HEADS WITH NON-ROTATING SPINDLES

0-1"/0-25MM

Because the spindle does not rotate, this tool is useful in driving positioning tables directly without an intermediate connecting device. It is also useful in gaging jobs where scratches on the work surface cannot be tolerated, or where there is risk of distortion when spindle meets work – as in measuring soft or elastic materials. Spindle wear is also reduced, since there is no rotational friction when its face contacts the work.

- Ring-type lock nut for quick and sure locking at any setting
- Available with or without the combination ratchet and speeder for uniform pressure and quicker adjustment

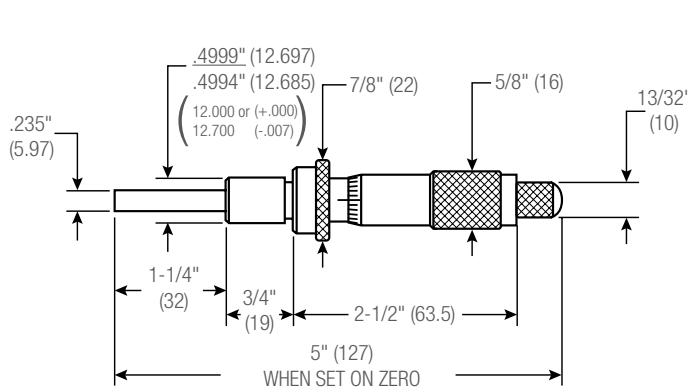

262L (0-1") and 262ML (0-25mm) dimensions

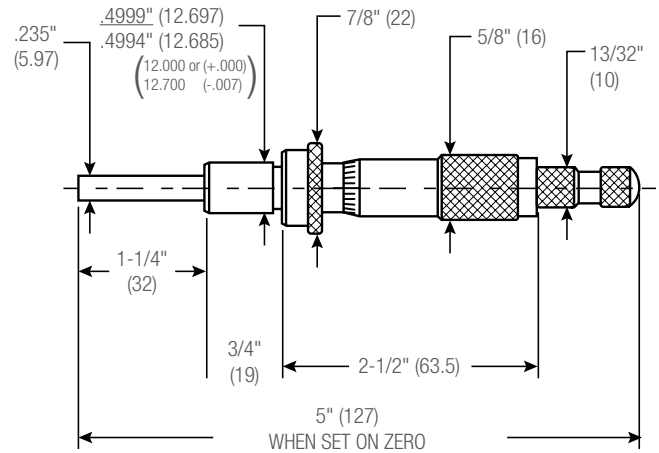

262RL (0-1") and 262MRL (0-25mm) dimensions

262 Micrometer Heads (0-1" Range)

Cat. No.	EDP	Graduation
262L	55945	.001"
262RL	55946	

262M Micrometer Heads (0-25mm Range)

Cat. No.	EDP	Graduation
262ML*	64347	0.01mm
262MRL*	65051	

0-25mm models specify clamping diameter 12mm or 12.7mm. 12.7mm sent unless otherwise ordered.



262L



MICROMETER HEADS

762 ELECTRONIC MICROMETER HEADS WITH ROTATING OR NON-ROTATING SPINDLES (WITH OUTPUT)

0-2"/0-50MM

READABILITY FEATURES

- Large digital readout is easy to read, reducing errors
- Conventional inch or millimeter graduations standard
- Attractive black wrinkle finish on frame
- Starrett no-glare satin chrome finish on thimble and sleeve

EASE-OF-HANDLING FEATURES

- Ring-type knurled lock nut
- Smooth friction thimble for uniform pressure on regular heads and combination ratchet and speeder on non-rotating heads

ACCURACY AND LONG-LIFE FEATURES

- Extremely hard and stable one-piece spindle (the heart of our accuracy)
- One 3-volt battery furnished for over a year of normal usage
- Auto OFF after 30 minutes of nonuse

FULL-FUNCTION ACTION FEATURES

- Inch/millimeter conversion
- "ME" millimeter models turn on in millimeter mode after battery installation
- Measurement HOLD button
- Ability to zero tool at any position
- Ability to retain and return to the true zero reading of the micrometer
- PRESET button to install any reading at any position
- RS232 data output port
- Works well with Starrett DataSure® Wireless Data Collection Systems

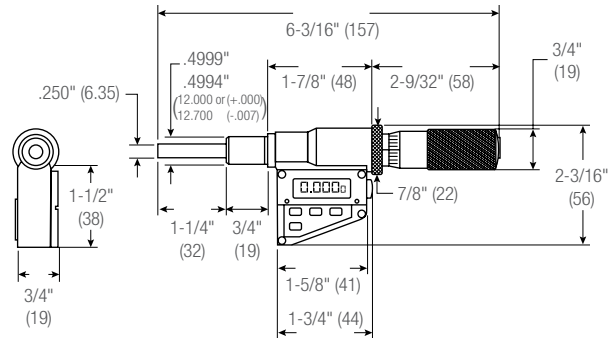

0-1" (0-25mm) dimensions

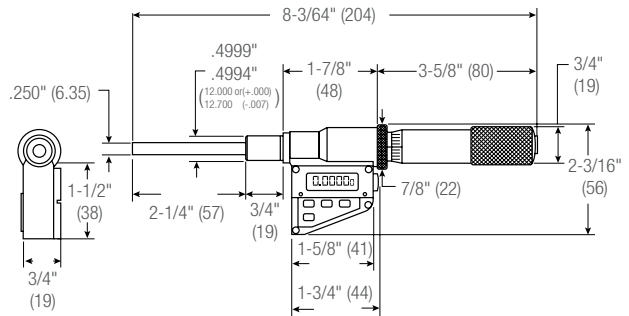

0-2" (0-50mm) dimensions



762 Micrometer Specifications			
Resolution		Accuracy	
in	mm	in	mm
.00005	0.001	±.0001 per inch	±0.003 per 25mm

762 Electronic Micrometer Heads with Standard Inch Graduations on Shell and Thimble

Cat. No.	EDP	Range	Description*
762XFL	65058	0-1"/0-25mm	Friction thimble, lock nut, carbide face
762NXRL	65060		Ratchet stop, lock nut, carbide face, non-rotating spindle
762XFL-2	65062	0-2"/0-50mm	Friction thimble, lock nut, carbide face

762M Electronic Micrometer Heads with Standard Millimeter Graduations on Shell and Thimble

Cat. No.	EDP	Range	Description*
762MEXFL-25	66077	0-25mm/0-1"	Friction thimble, lock nut, carbide face
762MEXFL-50	66137	0-50mm/0-2"	Friction thimble, lock nut, carbide face

Cable Information for 762 and 762M Electronic Micrometer Heads

Part No.	EDP	Description
733SCKB	69888	USB cable to PC (In focused window)
733SCU	69898	USB cable to computer running SPC Data Collection Software
733SCM	69893	Connection to Multiplexer (7612, 7613 or RMS 2704)
PT61963	66636	Computer Interface Cable Complete to PC (RS232C)
PT61120	65446	One 3-Volt Battery CR2450

*1/2" (12.7mm) clamping diameter sent unless otherwise specified.



MICROMETER HEADS

464P MICROMETER HEADS

0-1/4"

460A MICROMETER HEADS

0-1/4"/0-6.5MM

460B MICROMETER HEADS

0-1/2"/0-13MM

These are plain micrometer heads with no lock nut or ratchet.

464P, 460A, 460MA, 460B and 460MB Micrometer Heads			
Cat. No.	EDP	Range	Graduation
464P	56657	0-1/4"	.001"
460A	64444	0-1/4"	.001"
460MA	64445	0-6.5mm	0.01mm
460B	64446	0-1/2"	.001"
460MB	64447	0-13mm	0.01mm



464P

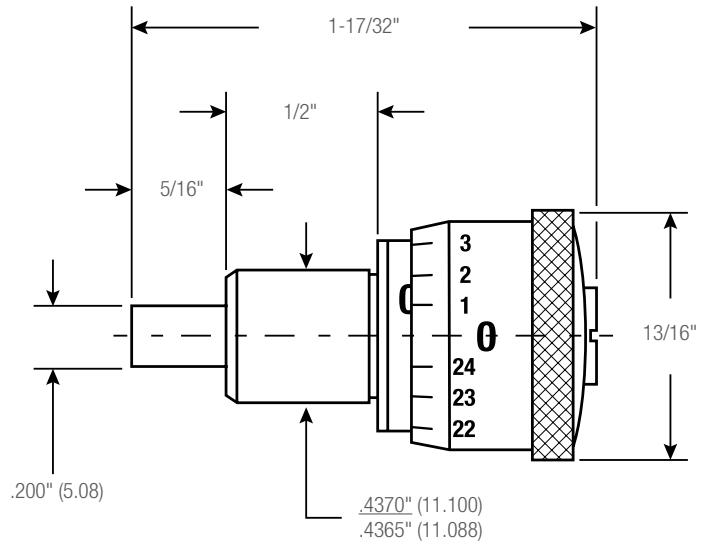

464P (0-1/4") dimensions



460A



460B

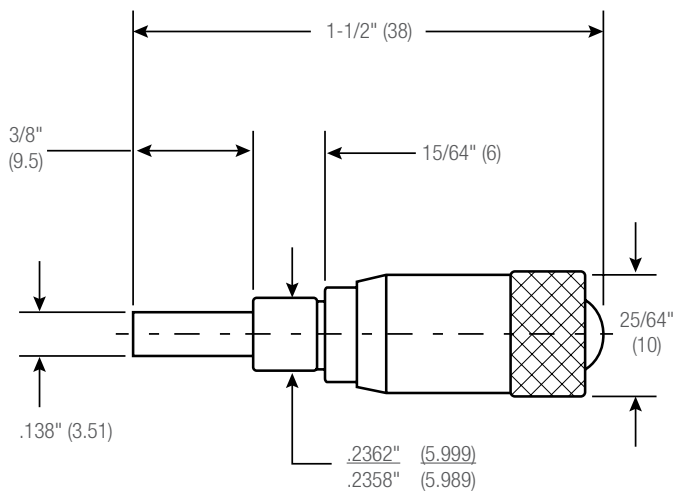

460A (0-1/4") and 460MA (0-6.5mm) dimensions

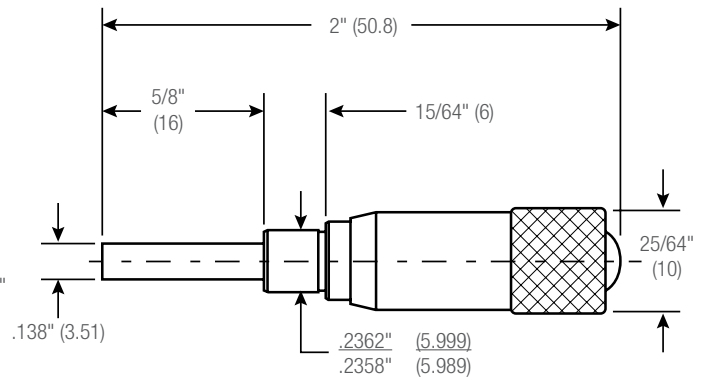

460B (0-1/2") and 460MB (0-13mm) dimensions



MICROMETER HEADS

463 MICROMETER HEADS

0-1/2"/0-13MM

1463 STAINLESS STEEL MICROMETER HEADS

0-1/2"/0-13MM

The 463 and 1463 Micrometer head are exactly the same, except that the 1463 is made from rust-resistant stainless steel. The reading surfaces are satin finished stainless steel for easy readability. Heads are available with the features below:

- Either combination ratchet and speeder for uniform pressure and quicker adjustment, or plain micrometer heads that depend on your own feel
- Ring-type lock nut for quick and sure locking at any setting
- Reverse reading, if needed
- Plain or carbide spindle faces

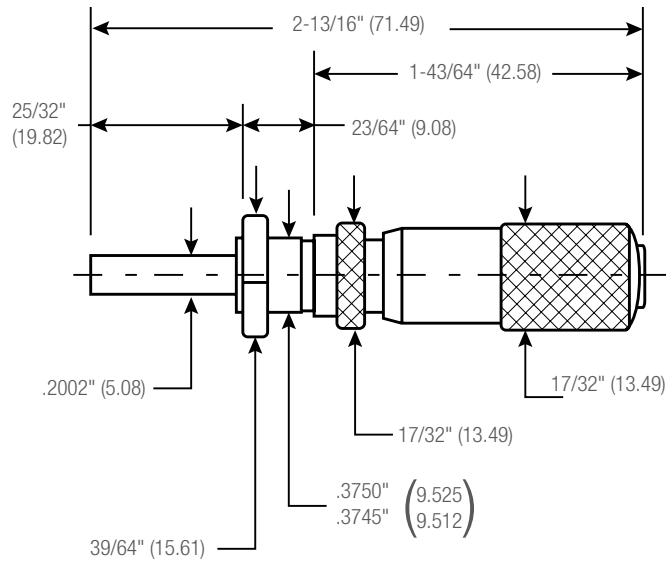

463L-38TN (0-1/2") dimensions

463 and 1463 Micrometer Heads

Cat. No.	EDP	Range	Graduation
463P	52440	0-1/2"	.001"
463P-38TN	67112		
463L	52442		
463XL	52451		
463L-38TN	67113		
463RL	52443		
463XRL	64687	0-1/2"	.0001"
RV463RL	57073		
RV463XRL	64688		
T463P	52446		
T463L	52448		
T463XL	64689		
T463RL	52449	0-13mm	0.01mm
T463XRL	65052		
463MP	52444		
463MRL	52452		
463MXRL	64691		
V463MRL	65053		
RV463MRL	60845		
1463RL	53207		
T1463RL	53209		
V1463MRL	64344	0-13mm	0.002mm

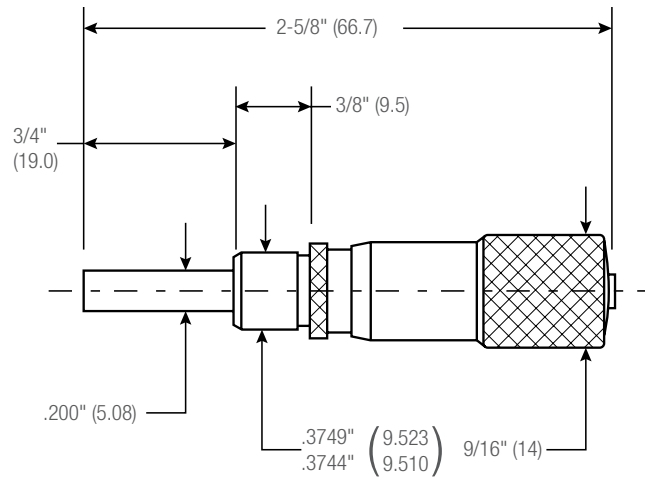

463P (0-1/2") and 463MP (0-13mm) dimensions



463RL

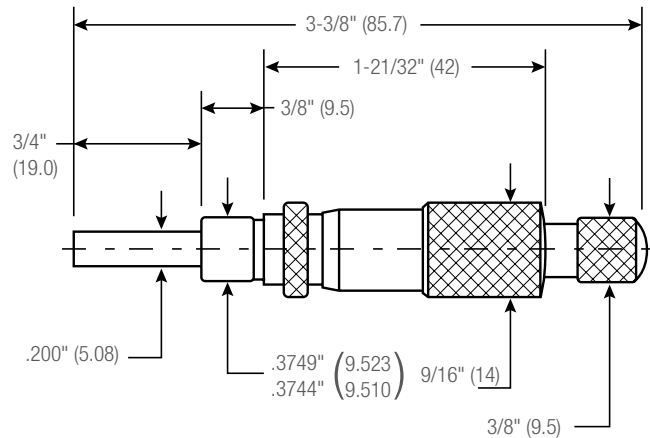

463RL (0-1/2") and 463MRL (0-13mm) dimensions



MICROMETER HEADS

263 AND 1263 MICROMETER HEADS

0-1"/0-25MM

- Reading surfaces satin-finished for easy readability
- No-glare, satin chrome finish on the 263, rust-resistant, stainless steel on the 1263
- Available with reverse reading, if needed
- Ring-type knurled lock nut for quick and sure locking
- Choice of smooth friction thimble for uniform pressure, combination ratchet and speeder for uniform pressure and quicker adjustment, or a plain micrometer head that depends on your own "feel"
- Spindle face available plain or with carbide
- Furnished with 1/2" (12.7mm) or 3/8" (9.5mm) diameter clamping surface

263 and 263M Micrometer Heads

Cat. No.	EDP	Range	Graduation				
263P	51251	0-1"	.001"				
263P-38	67108						
263P-38TN	67110						
263L	51253						
263XL	51265						
263L-38	67109						
263L-38TN	67111						
263RL	51254						
263FL	51256						
RV263RL	57071						
T263P	51258	0-1"	.0001"				
T263L	51260						
T263XL	65054						
T263RL	51261						
263MP*	51275			0-25mm	0.01mm		
263ML*	51276						
263MRL*	51257						
263MXL*	65055						
V263MRL*	55962					0-25mm	0.001mm
RV263MRL*	64948						
V263MXRL*	65056						

1263 and 1263M Stainless Steel Micrometer Heads

Cat. No.	EDP	Range	Graduation
1263L	53200	0-1"	.001"
1263RL	53201	0-1"	.0001"
T1263RL	53203	0-1"	.0001"
V1263MRL*	64345	0-25mm	0.001mm

*0-25mm models specify clamping diameter 12 or 12.7mm. 12.7mm sent unless otherwise ordered.

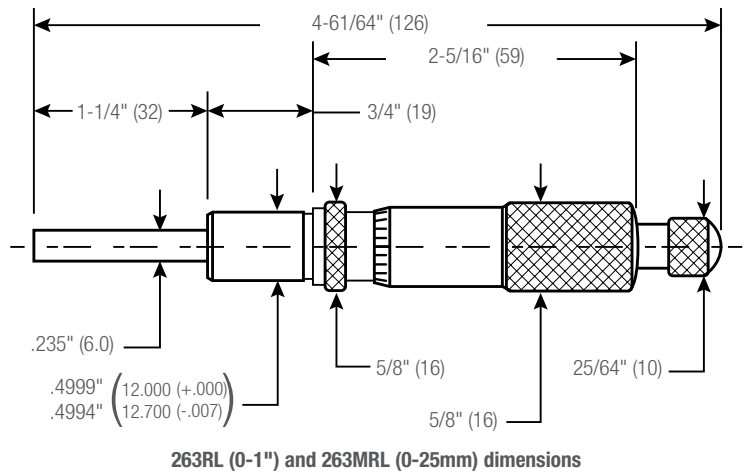
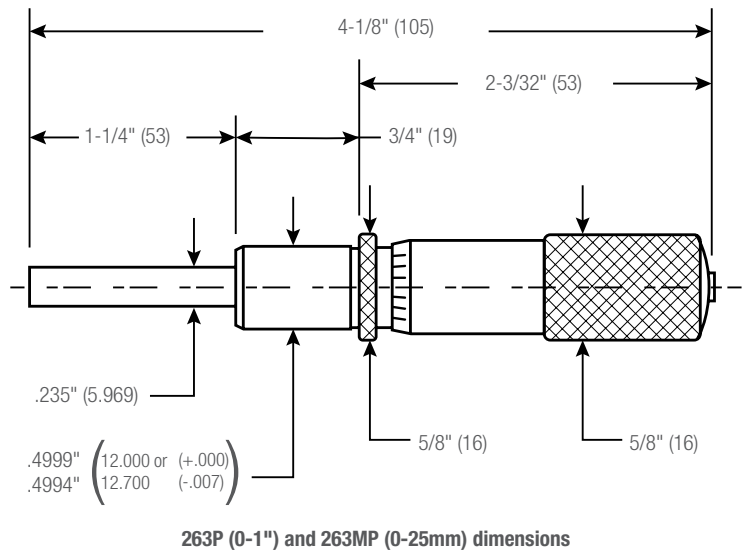
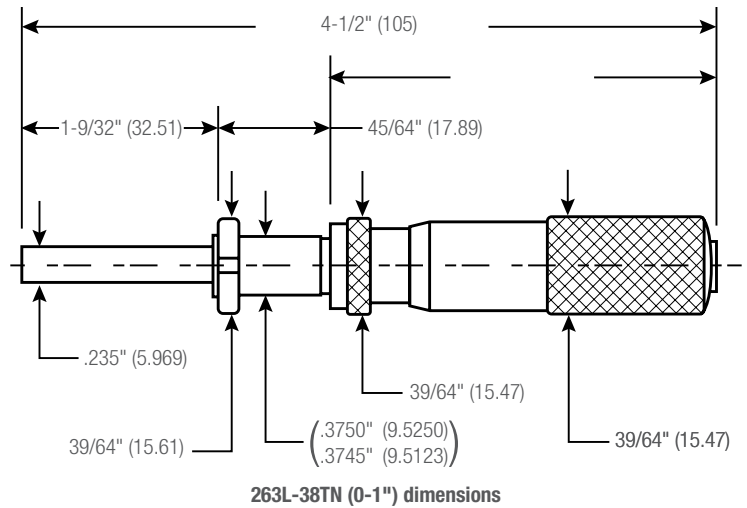

MICROMETER HEADS

363 Digital Micrometer Heads

0-1"/0-25MM

READABILITY FEATURES

- Clear, easily read numbers reduce errors
- No-glare black finish on the frame
- Starrett no-glare satin chrome finish on thimble and sleeve
- .001" or 0.01mm is read directly from the counter
- Reverse reading, if needed

EASE-OF-HANDLING FEATURES

- Ring-type knurled lock nut for quick and sure locking
- Choice of smooth friction thimble for uniform pressure or combination ratchet and speeder for uniform pressure and quicker adjustment

ACCURACY AND LONG-LIFE FEATURES

- Extremely hard and stable one-piece spindle (the heart of our accuracy)

363 Digital Micrometer Heads (0-1" Range)

Cat. No.	EDP	Graduation
363L	56297	.001"
363RL	56298	
363FL	56299	
RV363RL	57072	

363M Digital Micrometer Heads (0-25mm Range)

Cat. No.	EDP	Graduation
363ML*	56302	0.01mm
363MRL*	56303	
363MFL*	56304	

*Specify clamping diameter (12 or 12.7mm). 12.7mm sent unless otherwise ordered.

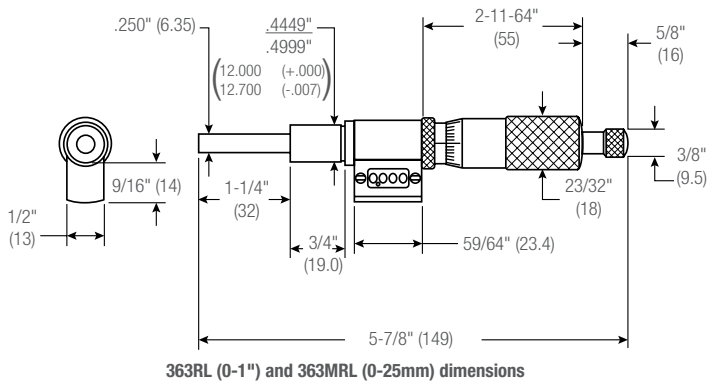

63 LONG RANGE MICROMETER HEADS

0-2"/0-50MM

When long spindle travel is required, the 63 Micrometer heads provide a range that will handle most applications, such as in electronic equipment, machine tools, special gages, tooling, etc.

- With or without ring-type lock nut for quick and sure locking
- With or without the combination ratchet and speeder for uniform pressure and quicker adjustment

63 Micrometer Heads (0-2" Range)

Cat. No.	EDP	Graduation
63P	50305	.001"
63L	50306	.001"
63RL	50307	.001"
T63P	50308	.0001"
T63RL	50309	.0001"

63M Micrometer Heads (0-50mm Range)

Cat. No.	EDP	Graduation
63MRL*	55939	0.01mm
V63MRL*	64343	0.002mm

*0-25mm models specify clamping diameter 12mm or 12.7mm. 12.7mm sent unless otherwise ordered.

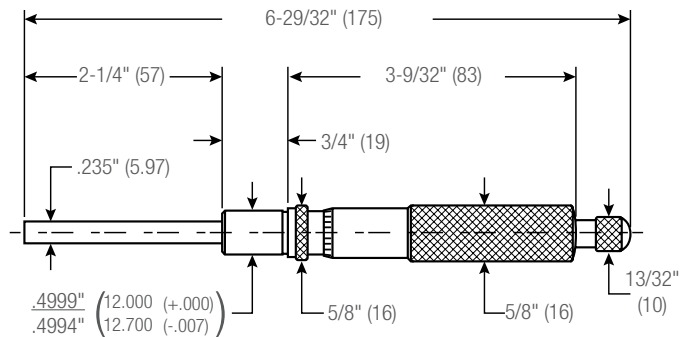
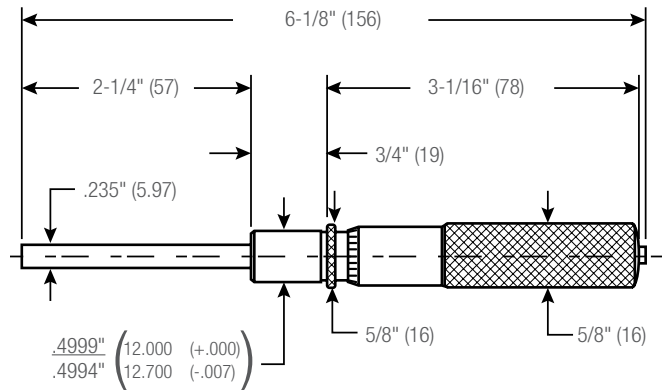

MICROMETER HEADS

663 HEAVY DUTY MICROMETER HEADS

0-1"/0-25MM

The 663 is similar to the 263 but features heavy duty construction with a larger diameter spindle, clamping surface and thimble.

- Available with lock nut and the combination ratchet and speeder for uniform pressure and quicker adjustment, or a plain micrometer head with lock nut only
- Ring-type lock nut for quick and sure locking

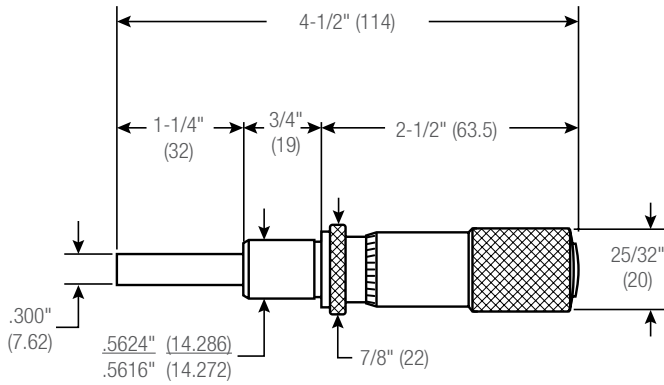

663L (0-1") and 663ML (0-25mm) dimensions

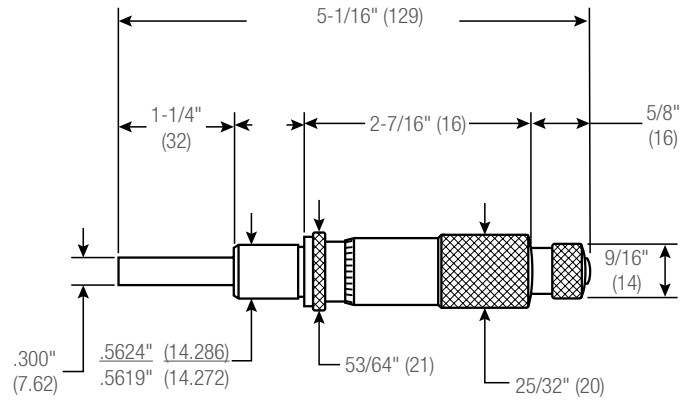

663RL (0-1") and 663MRL (0-25mm) dimensions

663 Heavy Duty Micrometer Heads (0-1" Range)		
Cat. No.	EDP	Graduation
663L	52772	.001"
663RL	52773	.001"
T663L	52777	.0001"
T663RL	52778	.0001"
663M Heavy Duty Micrometer Heads (0-25mm Range)		
Cat. No.	EDP	Graduation
663MRL	52774	0.01mm
V663MRL	64342	0.001mm



663RL

MICROMETER HEADS

465, 468 DIRECT-READING, LARGE MICROMETER HEADS

0-2"/0-50MM

These large micrometer heads are designed for use with electronic equipment requiring ultra-fine adjustment for machine tools, fixtures, special gages and tools, special mountings, or wherever micrometer accuracy in setting and adjustment is required.

Another highly useful feature is the spindle adjustment, which permits adjusting the spindle length approximately $\pm 1/16"$ (1.5mm). If the spindle is to be located against a definite stop and a different zero position is required, first loosen the cap screw in the end of the thimble, position the spindle to the desired location, then holding the spindle in position, rotate the thimble to zero and retighten the cap screw. In achieving this adjustable feature, we have still retained our positive taper-lock large thimble bearing.

The 468 Micrometer heads are exactly the same as the 465, except that they have double figures in red and black on the sleeve and thimble, permitting reading both ways with the spindle moving in either direction. This feature is invaluable on many instruments and microwave applications.

READABILITY, ACCURACY AND LONG-LIFE FEATURES

- 2-1/16" (52mm) thimble diameter with widely spaced .0001" or 0.002mm graduations for direct reading
- All graduations are direct reading – no vernier lines to match
- All reading surfaces have Starrett satin chrome finish as the no-glare background for the sharp lines and figures
- All graduations on sleeves and thimbles have advanced styling with staggered graduations for easy reading
- The spindle is carbide faced for long life
- Thimble and sleeve are made of aluminum to reduce weight
- Furnished with a speeder (not a ratchet) for quicker adjustment
- Extremely hard and stable one-piece spindle for accuracy and long-life
- Micro-lapped measuring face for flatness and squareness
- Quick and easy adjustment

465 Micrometer Heads			
Cat. No.	EDP	Range	Graduation
T465XSP-1	67121	0-1"	.0001"
T465XSP-2	67122	0-2"	.0001"
465MXSP-25*	67123	0-25mm	0.002mm
465MXSP-50*	67124	0-50mm	0.002mm
468 Micrometer Heads			
Cat. No.	EDP	Range	Graduation
T468XSP-1	67125	0-1"	.0001"
T468XSP-2	67126	0-2"	.0001"
468MXSP-25*	67127	0-25mm	0.002mm
468MXSP-50*	67128	0-50mm	0.002mm

*Metric models specify clamping diameter 25 or 25.4mm. 25.4mm sent unless otherwise ordered.



T465XSP-1

T468XSP-1 with double figures in red and black on sleeve and thimble for reading both ways.

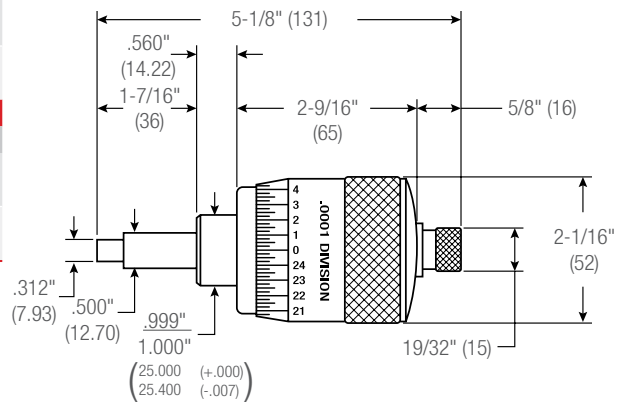

465, 468 Models (0-1"/0-25mm) dimensions

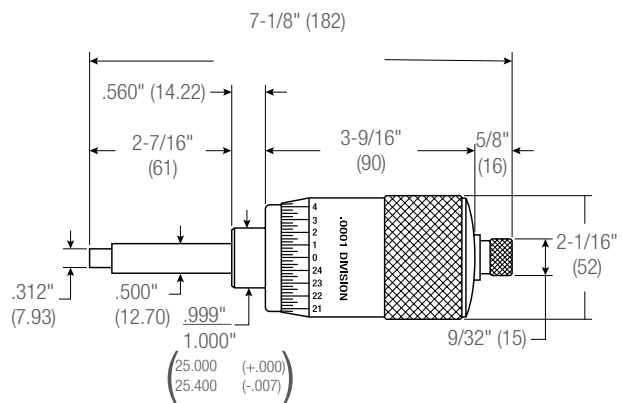

465, 468 Models (0-2"/0-50mm) dimensions



MICROMETER HEADS

469 LARGE, SUPER-PRECISION MICROMETER HEADS

0-1"/0-25MM

These are our most accurate micrometer heads. They are also available on special order with double graduations in red and black on the sleeve and thimble, permitting readings both ways with the spindle moving in either direction.

These micrometer heads have a 4-1/16" (103mm) thimble diameter and are graduated to .0001", .000050", 0.001mm, or 0.002mm for direct reading. They also have staggered graduations for easy counting and reading of lines. Spindle is carbide faced for long life.

469 Large, Super-Precision Micrometer Heads (0-1" Range)		
Cat. No.	EDP	Graduation
T469HXSP	67129	.000050"
T469XSP	67130	.0001"
469M Large, Super-Precision Micrometer Heads (0-25mm Range)		
Cat. No.	EDP	Graduation
469MHXSP*	67131	0.001mm
469MXSP*	67132	0.002mm

*Metric models specify clamping diameter 25 or 25.4mm. 25.4mm sent unless otherwise ordered.
Also available on special order with double graduations for reading both ways with spindle moving in either direction.

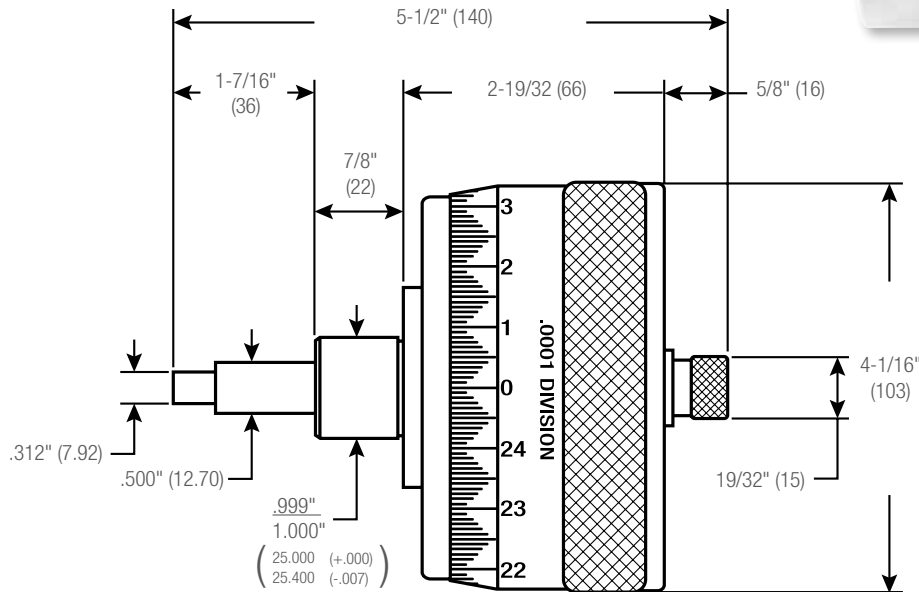
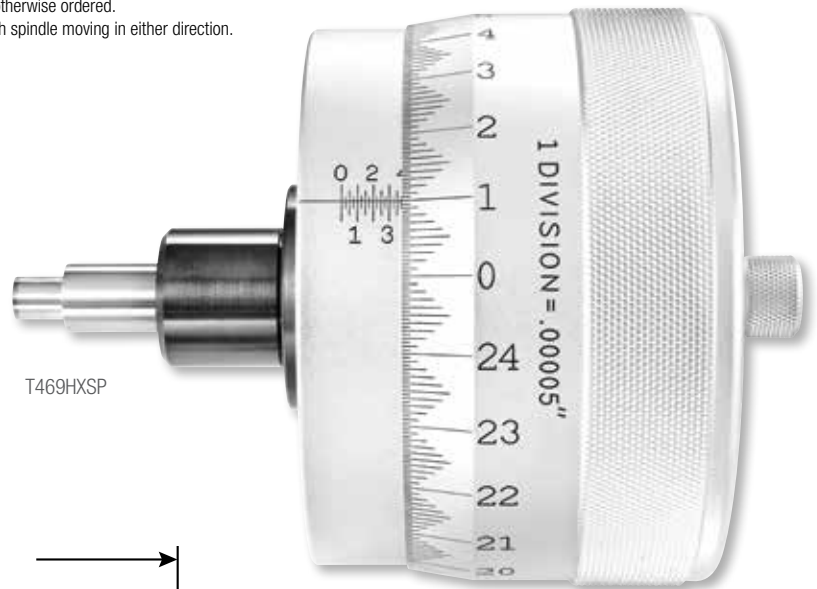

469 (0-1") and 469M (0-25mm) dimensions



INDICATING MICROMETERS

NEW!

430 INDICATING MICROMETER

The 430 Dial Indicating Micrometer has a Vernier scale in inch for taking precise outside diameter (OD) measurements and dial gage for Go/No-Go (GO/NG) tolerance inspection. A retractable, quick-release anvil allows for uniform consistent pressure during measurement.

430 Indicating Micrometers	
Cat. No.	EDP
430XLZ-1	72533
3206 Outside Micrometer Stand	
Cat. No.	EDP
3206	68917
Specifications	
Micrometer Range	0-1"
Indicator Range	±.0020"
Micrometer Resolution	.0001"
Indicator Resolution	.00005"
Measuring Force	5-10N (500-1000gf)
Measuring Faces	Carbide
Repeatability	±.00005"
Flatness	.000012"
Parallelism	.000036"

FEATURES

- Retractable, quick release anvil for uniform, consistent, and fast measurement
- Insulated frame to prevent thermal expansion/contraction
- Balanced frame and thimble design for ease of use
- Carbide measuring finish on anvils
- Friction thimble
- Satin chrome finish for rust and glare resistance
- Spindle lock
- Supplied with custom wooden case

MICROMETERS



430XLZ-1

HOW TO USE FOR DIRECT MEASURE AND AS A COMPARATOR

For direct measuring, the micrometer head is set to zero and the dial indicator is set to zero by the bezel adjustment. Any workpiece within the 1" (25mm) range can then be measured by the micrometer head in ten-thousandths of an inch (.0001" or 0.002mm). The indicator must read zero for each measurement.

If used as a comparator, first set the head and the indicator to zero as previously explained. Then adjust the micrometer head to the desired dimension to be checked. After retracting the anvil, work is placed on the table between anvil and spindle and the anvil is then released so anvil and spindle contact the work. Plus or minus deviation from the nominal work size is then read from the dial indicator in fifty-millionths of an inch (.000050") or 0.002mm.



BENCH MICROMETERS

777 ELECTRONIC BENCH MICROMETERS (WITH OUTPUT)

0-1"/0-25MM

The 777 Electronic Bench Micrometer is especially suited for precision measurements where the work must be brought to the gage.

Work is staged between the anvil and spindle on an adjustable table, which can be raised to a selected height and locked in position by turning a knurled thumb screw on back of the base. Made of cast iron with black wrinkle finish, the base is heavily proportioned to sustain gage accuracy and assure stability in use. It stands on three machined pads.

With Standard Inch Graduations on Shell and Thimble

Cat. No.	EDP	Description
777XFLZ	67135	0-1"/0-25mm Range

With Standard Millimeter Graduations on Shell and Thimble

Cat. No.	EDP	Description
777MEXFLZ	67136	0-25mm/0-1" Range

Cable Information

Part No.	EDP	Description
733SCKB	69888	USB cable to PC (In focused window)
733SCU	69898	Cable to computer running SPC Data Collection Software
733SCM	69893	Connection to 7612, 7613 Multiplexer or RMS 2704
PT61963	66636	Computer Interface Cable Complete to PC (RS232C)
PT61120	65446	One 3-Volt Battery CR2450

READABILITY FEATURES

- Large, right-sized, high-contrast LCD digital readout is easy to read and reduces errors
- Conventional inch or millimeter graduations standard
- Attractive no-glare black wrinkle finish on the frame

EASE-OF-HANDLING FEATURES

- Ring-type knurled lock nut for quick and sure locking
- Smooth friction thimble for uniform pressure

ACCURACY AND LONG-LIFE FEATURES

- Extremely hard and stable one-piece spindle
- The spindle and anvil are carbide faced for long life
- One 3-volt battery furnished for dependable power and over one year's normal usage
- Automatic OFF after 30 minutes of nonuse
- Starrett workmanship

FULL-FUNCTION ACTION FEATURES

- Instant inch/millimeter conversion
- "ME" millimeter model will turn on in the millimeter mode after installation of a new battery
- Measurement HOLD button
- Ability to zero tool at any position
- Ability to retain and return to the true zero reading of the micrometer
- PRESET button to install any reading at any position
- Ability to install minimum and maximum limits
- RS232 data output port
- Works well with DataSure® Wireless Data Collection Systems



777MEXFLZ

BENCH MICROMETERS

673 DIRECT-READING BENCH MICROMETERS

0-2"/0-50MM

The 673 Bench Micrometer is a high precision instrument, ideal for bench use either in a shop environment or inspection laboratory. It can be used as a comparator measuring to fifty-millionths of an inch (.000050") or two-thousandths of a mm (0.002mm) or for direct measuring to .0001" or 0.002mm. Work lengths up to 2" or 50mm can be measured.

- The base is a heavy, rigid casting, incorporating at the left end a movable anvil which actuates a linear, friction-free motion transfer mechanism between the anvil and the indicator. This assures high accuracy.
- The large thimble diameter, approximately 3" (77mm), makes possible widely spaced graduations that are easy to read without a vernier scale reference
- Advanced, staggered design and quick reading graduations in combination with Starrett no-glare satin chrome finish on both thimble and sleeve also contribute to easier, faster readings
- The head is furnished with a speeder and has a special ring-type lock nut which firmly holds the spindle at any setting without distortion
- Another useful feature is the adjustable work table centered beneath the anvil and spindle. Work can be accurately aligned between the anvil and spindle by adjusting the table to the proper height and locking it in position.
- The spindle and anvil are carbide faced for long life
- To read to ten-millionths of an inch (.000010") or 0.0001mm, this bench micrometer can be used with both the 776 Electronic Digital Gage Amplifier (LVDT probe 776-2Z) or on the 717 Analog Amplifier (LVDT probe 715-2Z). Both require 673A adapter.

673 and 673M Direct-Reading Bench Micrometers

Cat. No.	EDP	Range Micrometer Head	Dial Indicator	Graduation Micrometer Head	Dial Indicator	Work Table
673XZ	67191	0-2"	.006" (0-3-0)	.0001"	.000050"	2-1/4" dia. and 7/8" vertical adjustment
673MXZ	67192	0-50mm	0.2mm (0-10-0)	0.002mm	0.002mm	57mm dia. and 22mm vertical adjustment

673 and 673M Accessories

Cat. No.	EDP	Description
673A	52891	Adapter for 715-2Z LVDT Length Probe (to connect both 717 and 776 Gage Amplifiers)
776-2Z	68818	LVDT Length Probe (776 Gage Amplifier)
715-2Z	64480	LVDT Length Probe (717 Gage Amplifier)

Anvil Pressure Adjustment – 8 oz. to 3 lb (0.23 to 1.36kg)



673M with 717 amplifier



HOW TO USE FOR DIRECT MEASURE AND AS A COMPARATOR

For direct measuring, the micrometer head is set to zero and the dial indicator is set to zero by the bezel adjustment. Any workpiece within the 2" (50mm) range can then be measured by the micrometer head in ten-thousandths of an inch (.0001" or 0.002mm). The indicator must read zero for each measurement.

If used as a comparator, first set the head and the indicator to zero as previously explained. Then adjust the micrometer head to the desired dimension to be checked. After retracting the anvil, work is placed on the table between anvil and spindle and the anvil is then released so anvil and spindle contact the work. Plus or minus deviation from the nominal work size is then read from the dial indicator in fifty-millionths of an inch (.000050") or 0.002mm.

END MEASURING RODS AND STANDARDS

234 END MEASURING RODS WITH SPHERICAL ENDS

1-24"/25-600MM

These rods or "standards" are for checking and setting micrometers of 2" capacity and larger, and are also used on machine tools for comparing gages, checking precision measuring tools, for measuring parallel surfaces, and many other types of work.

They are made of special tool steel in rod form with ends hardened and accurately lapped to a spherical radius.

Available plain or with insulated handles to minimize expansion by heat when held in the hand. 1-6" (25-150mm) sizes are 1/4" (6.3mm) diameter; 7-11" (175-275mm) sizes, 3/8" (9.5mm) diameter; 12-24" (300-600mm) sizes are 7/16" (11mm) diameter.

NOTE: These standards are the ones used for all micrometers furnished with standards. Larger sizes available on special order.

234 End Measuring Rods

With Insulating Handle		
Cat. No.	EDP	Length
234A-1	50969	1"
234A-2	50971	2"
234A-3	50973	3"
234A-4	50975	4"
234A-5	50977	5"
234A-6	50979	6"
234A-7	50981	7"
234A-8	50983	8"
234A-9	50985	9"
234A-10	50987	10"
234A-11	50989	11"
234A-12	50991	12"
234A-13	50993	13"
234A-14	50995	14"
234A-15	50997	15"
234A-16	50999	16"
234A-17	51001	17"
234A-18	51003	18"
234A-19	51005	19"
234A-20	51007	20"
234A-21	51009	21"
234A-22	51011	22"
234A-23	51013	23"
234A-24	51015	24"

234M End Measuring Rods

With Insulating Handle		
Cat. No.	EDP	Length
234MA-25	50970	25mm
234MA-50	50972	50mm
234MA-75	50974	75mm
234MA-100	50976	100mm
234MA-125	50978	125mm
234MA-150	50980	150mm
234MA-175	50982	175mm
234MA-200	50984	200mm
234MA-225	50986	225mm
234MA-250	50988	250mm
234MA-275	50990	275mm
234MA-300	50992	300mm
234MA-325	50994	325mm
234MA-350	50996	350mm
234MA-375	50998	375mm
234MA-400	51000	400mm
234MA-425	51002	425mm
234MA-450	51004	450mm
234MA-475	51006	475mm
234MA-500	51008	500mm
234MA-525	51010	525mm
234MA-550	51012	550mm
234MA-575	51014	575mm
234MA-600	51016	600mm

Standards for S436.1 and S436 Micrometer Sets		With SLC		
Cat. No.	EDP	Cat. No.	EDP	Description
S234C	50852			Set of two standards only
S234D	51897			Set of three standards only
S234E	50860	S234E W/SLC	66878	Set of five standards only
S234G	51929	S234G W/SLC	66877	Set of eleven standards only
S234F	51917	S234F W/SLC	66879	Set of six standards only
S234J	64146			Set of twelve standards only

Standards for S436.1M and S436M Micrometer Sets		
Cat. No.	EDP	Description
S234MC	51893	Set of two standards only
S234MD	51901	Set of three standards only
S234ME	51913	Set of five standards only
S234MF	51925	Set of six standards only
S234MG	51937	Set of eleven standards only
S234MJ	64467	Set of twelve standards only



234A-2



234A-6

END MEASURING RODS

PRECISION END MEASURING RODS AND INSIDE MICROMETERS

The following pages show our varied line of precision end measuring rods and inside micrometers. The variations are fixed-range or adjustable-range micrometers and solid or tubular measuring rods.



Unless otherwise noted under the individual tools, all have these features:

- Balanced design for better feel and accurate measurement
- All contact points are hardened and ground for better accuracy and long life
- Satin chrome finish on all micrometer heads and reading surfaces that resist rust and also make for easy reading by providing a no-glare background for the sharp lines and figures
- Hardened and stabilized spindle for accuracy and long life
- Advanced sleeve design with staggered lines and distinct figures for precise and easy readability
- Quick and easy adjustment
- Starrett workmanship
- Inside Micrometers 121, 124, 823 and 824 by design have a firmer rotation than regular micrometers. This is to limit the tendency of the micrometer head to rotate when withdrawn from the workpiece.

MEASURING TIPS FOR INSIDE MEASUREMENTS

Whether to use a two-point or three-point contact measuring tool is usually a matter of preference, but there are some differences.

A two-point contact rod-type inside micrometer shown in this section is usually lighter, easier to handle, and more versatile over long ranges from approximately 6-107" (150-2700mm). Any two-point contact micrometer, regardless of range, can probe a hole better to find the geometry of that hole than a three-point contact.

Most three-point contact tools have setting rings to ensure accuracy. If you desire very close tolerance work with two-point contact inside micrometers, it is recommended that they be set to a ring gage or to an outside micrometer.

A three-point contact micrometer shown in the Bore Gages section has an advantage in that it can be seated in position more quickly than a two-point contact tool. Usually these tools can also be read to a finer accuracy. The three-point tool will tell the maximum true diameter that can enter the hole a little faster than a two-point contact tool.

Micrometer heads used in these tools are accurate to ± 0.0001 " or 0.002mm, but overall accuracy on tools that add rods is dependent on good practice and technique.

To ensure accuracy, these practices should be followed:

- Always make sure that there are no specks of dirt between the clamping surfaces of the rods and micrometer heads
- Tighten all rods uniformly, not too tight, not too loose, but a fairly firm assembly
- Assemble long sections vertically or, with support, horizontally
- Because temperature can affect long rods used in these tools, they should be assembled in the same environment in which they will be used

For additional information, refer to the Bore Gage Section.



INSIDE MICROMETERS

128 COMBINATION HEAD WITH INSIDE MICROMETER

The combination head for inside micrometers combines the precision of a dial indicator sensor and the linear accuracy of a micrometer. This combination of indicator and micrometer reduces the need for operator "feel" and provides faster readings with increased reliability.

This head is interchangeable with the 128 End Rods and extension combinations.

For direct measurements, the dial indicator hand and the telltale hand must both register zero before reading the micrometer. As a comparator, the micrometer is first set to the nominal dimension and \pm deviation from zero is read from the dial indicator. The gage should be rocked to obtain a minimum reading on the indicator. Out-of-roundness can also be checked – any variation being shown by the indicator.

For inch-reading tools, the head can be adjusted within a range of 2". It extends the overall range by an additional 5". The special 81-138J Jeweled Non-Shock Indicator is graduated .0005", range \pm .040" and reads 0-40 on both the plus and minus dials.

For millimeter-reading tools, the head can be adjusted within a range of 50mm. This extends the overall range an additional 125mm. The special 81-181J Jeweled Non-Shock Indicator is graduated 0.01mm, range \pm 1mm and reads 0-100mm on both the plus and minus dials.

All inside micrometer masters should be used vertically with the shoulder on the indicator end of the head, seated squarely.

128 SETS

6-294"/150-7350MM

Each set consists of a satin-chrome micrometer head which can be used in combination with any one or more of a series of rigid, tubular steel measuring rods to obtain the required length.

The micrometer head is a modification of our 63, which has a 2" (50mm) range. The head has a basic length of 4" (100mm) which can be lengthened to 6" (150mm) by means of its measuring range. Besides those listed on the lead page of this section, the 128 Sets have these additional features:

- For inside measurements from 6-294" (150-7350mm) (longer sizes are also available on special order)
- Interchangeable tubular steel measuring rods and extension rods are lightweight with extreme rigidity. Rods screw into each other and seat against hardened ground and lapped surfaces necessary for high accuracy. Rod diameter 5/8" (16mm).
- Rods are provided with insulated handles to minimize expansion from hand heat. All rods marked with length
- All rod anvil contacts are hardened and ground
- All measuring rod anvil contacts are adjustable (plain extension rods are not adjustable)
- Adjustable, ground steel supporting collars (placed in "V" grooves when used in the horizontal position)



128CZ

128 and 128M Combination Head with Inside Micrometer Sets

Cat. No.	EDP	Description
128	64381	Inch-reading combination head with setting master
128M	68117	Millimeter-reading combination head with setting master



128 with rod

128

128 and 128M Micrometer Head Sets

Cat. No.	EDP	Range with Micrometer Head	Movement of Screw	Grad.	Description	Range with Combination Head
128AZ	64375	6-78"	2"	.001"	With (1) 4-6" head, (1) each 2", 4", 6", 8", 10", 12" rods, (1) 12" ext., (2) 24" ext.	11-83"
128BZ	64376	6-150"	2"	.001"	With (1) 4-6" head, (1) each 2", 4", 6", 8", 10", 12" rods, (1) 12" ext., (5) 24" ext.	11-155"
128CZ	64377	6-294"	2"	.001"	With (1) 4-6" Head, (1) each 2", 4", 6", 8", 10", 12" rods, (1) 12" ext., (1) 24" ext.	11-299"
128MAZ	64378	150-1950mm	50mm	0.01mm	With (1) 100-150mm head, (1) ea. 50, 100, 150, 200, 250, 300mm rods, (1) 300mm ext., (2) 600mm ext.	300-2100mm
128MBZ	64379	150-3750mm	50mm	0.01mm	With (1) 100-150mm head, (1) ea. 50, 100, 150, 200, 250, 300mm rods, (1) 300mm ext., (5) 600mm ext.	300-3900mm
128MCZ	64380	150-7350mm	50mm	0.01mm	With (1) 100-150mm head, (1) ea. 50, 100, 150, 200, 250, 300mm rods, (1) 300mm ext., (11) 600mm ext.	300-7500mm

MICROMETER SETS

124 SOLID-ROD INSIDE MICROMETER SETS

2-32"/50-800MM

These are the most popular inside micrometers because of their lightness, ease of use, and range. They are very useful for measuring inside diameters of cylinders and rings, measuring parallel surfaces, etc.

The desired range is obtained by assembling rods and spacing collars to the micrometer head. Measuring rods are provided with a shoulder that is set accurately in the micrometer head and locked in position. When assembling rods to the A and B heads, the reading line on the micrometer head should be lined up with the marking on each rod (except for the 2-3" and the 50-75mm rods).

Rod diameters are approximately 1/4" (6mm) on the A and B sizes, and approximately 11/32" (8.5mm) on the C size. Each rod has individual length adjustment for the anvil by means of special wrenches furnished.

- Measuring rods are solid and assembled on one side of the micrometer head
- Insulated rods marked with length
- Hardened and ground anvils on rods, adjustable for length. Head anvil is hardened and ground
- Quick-reading figures – every thousandth numbered on inch reading tools
- Convenient handle is available to provide reach for use in deep holes. Handle screws into the micrometer head in place of the dummy screw, which is opposite a rod lock screw. Distance from the end of the handle to the center line is 6-1/4" (158mm).



124AZ



H124 Head

124 Solid-Rod Inside Micrometer Sets (.001" Graduation)

Without Case		With Case		Range	Screw Movement	Measuring Rods	Spacing Collars
Cat. No.	EDP	Cat. No.	EDP				
124A	50540	124AZ	50542	2-8"	1/2"	6	One 1/2"
124B	50544	124BZ	50546	2-12"	1/2"	10	One 1/2"
124C	50548	124CZ	50550	8-32"	1"	4	One 1", Two 2"
124D	50552	124DZ	50554	2-32"	1/2 and 1" (2 heads)	Set 124A and 124C	

124M Solid-Rod Inside Micrometer Sets (0.01mm Graduation)

Without Case		With Case		Range	Screw Movement	Measuring Rods	Spacing Collars
Cat. No.	EDP	Cat. No.	EDP				
124MA	50541	124MAZ	56141	50-200mm	13mm	6	One 12mm
124MB	50545	124MBZ	56142	50-300mm	13mm	10	One 12mm
124MC	50549	124MCZ	56143	200-800mm	25mm	4	One 25mm, Two 50mm
124MD	50553	124MDZ	56144	50-800mm	13 and 25mm (2 heads)	Comprised of sets 124MA and 124MC	

Accessory for 124 and 124M Solid-Rod Inside Micrometer Sets

Cat. No.	EDP	Description
124H	50556	6-1/4" (158mm) handle



MICROMETER SETS

823 TUBULAR INSIDE MICROMETER SETS

1-1/2-40"/40-1000MM

The 823 Micrometers are highly useful tools for internal linear measurements such as measuring cylinders, rings, setting calipers, comparing gages and measuring parallel surfaces.

The extension rods are made of steel tubing, light in weight, yet extremely rigid. Rods are approximately 3/8" (9.5mm) diameter to meet the requirements of mechanics who prefer this larger diameter. By removing the hardened and ground anvil ends (end caps) of the micrometer head, the rods may be attached to either or both ends of the micrometer as preferred. Each rod may be individually adjusted for wear by the hardened and ground anvil at the end.

- Tubular measuring rods are lightweight, yet extremely rigid. Rods are insulated, with the exception of 1/2" (13mm) and 1" (25mm) sizes.
- Each rod is marked with length
- Hardened and ground anvils on rods are adjustable for length. Head anvil is hardened and ground.
- Interchangeable anvils on both 1/2" (13mm) and 1" (25mm) heads
- Quick reading figures – every thousandth numbered on inch reading tools
- Lock nut furnished on 1" (25mm) heads
- 5-1/2" (140mm) long, convenient handle furnished on A, B, F micrometers may be clamped where it will provide correct balance and reach



823AZ 1-1/2-8" set with tool, rods, handle and wrenches

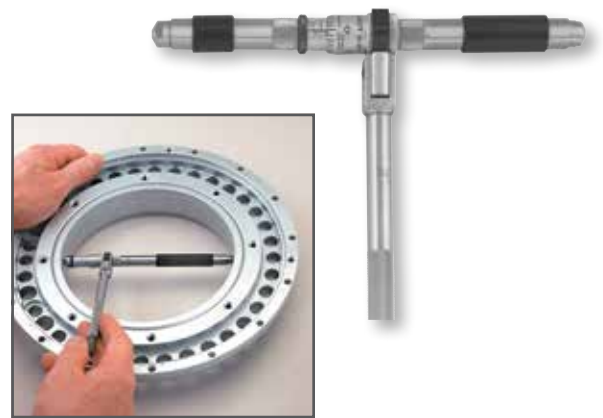

Rods attachable as shown to either one or both ends of the head ensures the best balance, feel, and ease of reading.



823EZ 4-40" set with tool, rods, handle and wrenches.

823 Tubular Inside Micrometer Sets (.001" Graduation)

Cat. No.	EDP	Range	Movement of Screw	Description
823AZ	53050	1-1/2-8"	1/2"	With 5 rods and handle
823BZ	53052	1-1/2-12"	1/2"	With 8 rods and handle
823CZ	53054	4-24"	1"	With 7 rods
823DZ	53055	4-32"	1"	With 8 rods
823EZ	53056	4-40"	1"	With 10 rods
823FZ	53058	1-1/2-32"	1/2 and 1" (2 heads)	With 10 rods and handle

823M Tubular Inside Micrometer Sets (0.01mm Graduation)

Cat. No.	EDP	Range	Movement of Screw	Description
823MAZ	53051	40-200mm	13mm	With 6 rods and handle
823MBZ	53053	40-300mm	13mm	With 8 rods and handle
823MEZ	53057	100-1000mm	25mm	With 10 rods

Each set furnished in attractive, protective case with assembly instructions for various measurements.

INSIDE MICROMETERS

121 LONG RANGE TUBULAR INSIDE MICROMETER SETS

32-107"

The 121 Tubular Inside Micrometers are designed for large internal measurements beyond the capacity of most other micrometers. Each set consists of a micrometer head mounted at the end of a tubular holder in which measuring rods can be inserted and adjusted to the desired size. Final size reading in thousandths of an inch (.001") is obtained using the micrometer head.

Rods and holder are made of steel tubing, light in weight, yet very rigid. Each rod is accurately graduated with inch divisions, which are set to the size desired by a line on the holder, and firmly held by a large, knurled clamping nut. The collet has a design that insures an extremely tight grip on the rods at any setting.

FEATURES

- Insulated rod holder to eliminate expansion by heat when hand held
- Attractive nickel-plated finish; satin-chrome finish on micrometer head reading surfaces
- Rods are accurately graduated in inches – micrometer head in thousandths of an inch
- Hardened and ground anvils. All rod anvils are adjustable.
- Quick, easy adjustment for micrometer screw

121 Long Range Tubular Inside Micrometer Sets (.001" Graduation)				
Cat. No.	EDP	Range	Movement of Screw	Description
121AZ	50492	32-57"	1"	With 1 graduated measuring rod
121BZ	50493	32-82"		With 2 graduated measuring rods and 1 extension rod
121CZ	50494	32-107"		With 3 graduated measuring rods and 2 extension rods

Each set furnished in attractive, protective case.



121CZ

824 FIXED RANGE INSIDE MICROMETERS AND SETS

2-12"/50-150MM

For those who prefer inside micrometers without interchangeable rods, Starrett offers this series of fixed range inside micrometers. The 824 and 824M can be ordered individually or in sets. All 824 and 824M Micrometers feature:

- Insulating handles on all sizes minimize possible expansion by heat when hand held
- Lock nuts (except 824AA and 824MAA)
- Adjustable contacts on thimble end
- Adjustable sleeve for head accuracy

824 Inside Micrometers (.001" Graduation)

Cat. No.	EDP	Range	Movement of Screw
824AA	56665	2-3"	1"
824A	56666	3-4"	
824B	56667	4-5"	
824C	56668	5-6"	
824D	56669	6-7"	
824E	56670	7-8"	
824F	56671	8-9"	
824G	56672	9-10"	
824H	56673	10-11"	
824J	56674	11-12"	
824K	56675	6-8"	2"
824L	56676	8-10"	
824N	56677	10-12"	

824M Inside Micrometers (0.01mm Graduation)

Cat. No.	EDP	Range	Movement of Screw
824MAA	64192	50-75mm	25mm
824MA	64193	75-100mm	
824MB	64194	100-125mm	
824MC	64195	125-150mm	

824 Fixed Range Inside Micrometer Sets

Cat. No.	EDP	Total Range	Description
S824AZ	56678	2-6"	4 micrometers, 1" range: 2-3", 3-4", 4-5", 5-6"
S824BZ	56679	2-12"	10 micrometers, 1" range: 2-3", 3-4", 4-5", 5-6", 6-7", 7-8", 8-9", 9-10", 10-11", 11-12"
S824CZ	56680	6-12"	3 micrometers, 2" range: 6-8", 8-10", 10-12"
S824DZ	56681	2-12"	7 micrometers, (4) 1" range, (3) 2" range: 2-3", 3-4", 4-5", 5-6", 6-8", 8-10", 10-12"

824M Fixed Range Inside Micrometer Sets

Cat. No.	EDP	Total Range	Description
S824MAZ	64196	50-150mm	4 micrometers, 25mm Range: 50-75mm, 75-100mm, 100-125mm, 125-150mm



INSIDE MICROMETERS

700 INSIDE MICROMETER CALIPERS

.200-2"/5-50MM

Caliper-type jaws permit quick inside measurements accurate to $\pm .0002"$ or $\pm 0.005\text{mm}$. Jaws are hardened and ground on a radius for accurate feel without cramping.

- Satin chrome reading surface is glare free and resists rust
- Smooth friction thimble for consistent readings
- Lock screw



700 Inside Micrometer Calipers (.001" Graduation)		
Cat. No.	EDP	Range
700A	52909	.200-1.200"
700B	52911	1-2"

700M Inside Micrometer Calipers (0.01mm Graduation)		
Cat. No.	EDP	Range
700MA	56063	5-30mm
700MB	56064	25-50mm

Case for 700 and 700M Inside Micrometer Calipers		
Cat. No.	EDP	Description
940	55359	Case for 700, 700M inside micrometer calipers

701 INTERNAL GROOVE MICROMETERS

.500-2.500"

Measures grooves for retaining rings and "O" rings, oil grooves, washer grooves, as well as bores and recesses. Depth of grooves up to 5/64" can be measured with 701A; and 7/32" with 701B. Tool is accurate to $\pm .0002"$.

- Hardened and ground gaging contacts are .030" thick
- Contacts have flush ends to gage grooves at the bottom of blind holes
- Satin chrome reading surface is glare free and resists rust
- Smooth friction thimble for consistent readings
- Lock screw



701 Internal Groove Micrometers (.001" Graduation)					
Cat. No.	EDP	Range	Min. Bore	Max. Depth Bore	Thickness Jaws
701A	52913	.500-1.500"	.500"	1/2"	.030"
701B	52915	1.500-2.500"	1.500"	7/8"	

Case for 701 Internal Groove Micrometers		
Cat. No.	EDP	Description
940	55359	Protective Case

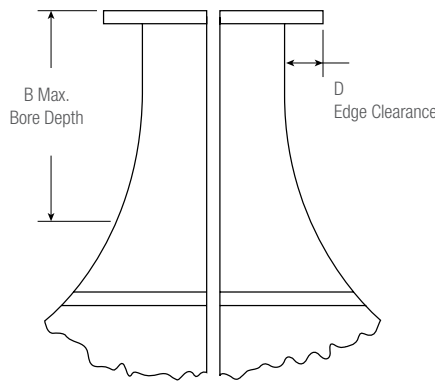
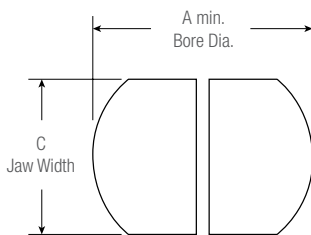

	701A	701B
Range	.5-1.5"	1.5-2.5"
A	.5"	1.5"
B	1/2"	3/4"
C	3/8"	3/8"
D	3/32"	1/4"



DEPTH MICROMETERS

749 ELECTRONIC MICROMETER DEPTH GAGE (WITH OUTPUT)

0-12"/0-300MM

The 749 Electronic Depth Micrometer has a wide 0-12" (0-300mm) range for measuring the depth of most holes, slots, shoulders and projections.

749 Electronic Micrometer Depth Gages, Standard Inch Graduations on Shell and Thimble		
Cat. No.	EDP	Description
749BZ-6RL	65063	0-6"/0-150mm range
749BZ-12RL	68854	0-12"/0-300mm range

749M Electronic Micrometer Depth Gages, Standard Millimeter Graduations on Shell and Thimble		
Cat. No.	EDP	Description
749MEBZ-150	66124	0-150mm/0-6" range
749MEBZ-300	68855	0-300mm/0-12" range

Rods Only for 749 and 749M Electronic Micrometer Depth Gages					
Part No.	EDP	mm	Part No.	EDP	Inch
PT99486	72493	0-25mm	PT99143	66331	0-1"
PT99487	72494	25-50mm	PT99183	66332	1-2"
PT99488	72495	50-75mm	PT99190	66333	2-3"
PT99489	72496	75-100mm	PT99266	66334	3-4"
PT99490	72497	100-125mm	PT99267	66335	4-5"
PT99491	72498	125-150mm	PT99268	66336	5-6"
PT99457	11626	150-175mm	PT99531	11632	6-7"
PT99458	11627	175-200mm	PT99532	11633	7-8"
PT99459	11628	200-225mm	PT99533	11634	8-9"
PT99460	11629	225-250mm	PT99534	11635	9-10"
PT99461	11630	250-275mm	PT99535	11636	10-11"
PT99462	11631	275-300mm	PT99536	11637	11-12"

Cable Information for 749 and 749M Electronic Micrometer Depth Gages		
Part No.	EDP	Description
PT61963	66636	Computer interface cable complete to PC (RS232C)
733SCU	69898	USB cable to computer running SPC Data Collection Software
733SCKB	69888	USB cable to PC (In focused window)
733SCM	69893	Connection to Multiplexer (7612, 7613 or RMS2704)
PT61120	65446	One 3-Volt battery CR2450

READABILITY FEATURES

- Large high-contrast LCD digital readout
- Resolution: .0001" (0.001mm)
- Inch or millimeter graduations standard
- No-glare black wrinkle finish frame
- No-glare satin chrome finish on thimble and sleeve

EASE-OF-HANDLING FEATURES

- Ring-type knurled lock nut
- Combination ratchet and speeder

ACCURACY AND LONG-LIFE FEATURES

- Ground and lapped one-piece spindle
- Base length 4" (100mm); rod diameter 5/32" (4mm)
- One 3-volt battery furnished with over one year's normal usage
- Automatic OFF after 30 minutes of nonuse
- Full-Function Action Features
- Instant inch/millimeter conversion
- "ME" millimeter model turns on in millimeter mode after battery installation
- Measurement HOLD button
- Ability to zero at any position and retain and return to true zero reading
- PRESET button to install any reading at any position
- Ability to install minimum and maximum limits
- RS232 data output port
- Works well with Starrett DataSure® Wireless Data Collection Systems

DEPTH MICROMETERS

Our varied line of electronic, mechanical digital and regular depth micrometers are available with base lengths from 2-1/2-6" (63.5-150mm) and can measure depths up to 9" (225mm). They are also available with rotating or non-rotating blades. All heads used in our depth micrometers are accurate to ± 0.0001 " or ± 0.002 mm.

Unless otherwise noted under the individual tools, they all have these features:

- A base shape design that will automatically position the fingers so that the base is easily held in place for measuring stability
- All precision screws are ground and lapped
- All bases and rods are hardened, ground, and lapped for permanent accuracy
- All reading surfaces have a satin chrome finish that resists rust and provides a no-glare background for the sharp lines and figures
- All measuring rods are adjustable
- Quick and easy adjustment



749MEBZ-150



DEPTH MICROMETERS

446 DIGITAL MICROMETER DEPTH GAGES

0-6"/0-150MM

446 Mechanical Digital Depth Micrometers are simple to use even by the inexperienced. Besides those listed on the lead page of this section, this tool has these additional features:

- Clear, easily read white numbers on black background reduce errors
- No-glare black finish on the frame
- .001" or 0.01mm is read directly from the counter
- Ring-type knurled lock nut for quick and sure locking
- Combination ratchet and speeder for uniform pressure and quicker adjustment
- Hardened, ground, and lapped base is 3" (75mm) long
- Measuring rods are 5/32" (4mm) diameter and are adjustable

446 Digital Micrometer Depth Gages (.001" Graduation)

Cat. No.	EDP	Range	Rods
446AZ-3RL	56288	0-3"	3
446AZ-6RL	56289	0-6"	6

446M Digital Micrometer Depth Gages (0.01mm Graduation)

Cat. No.	EDP	Range	Rods
446MAZ-75RL	56294	0-75mm	3
446MAZ-150RL	56295	0-150mm	6

Rods Only for 446 & 446M Digital Micrometer Depth Gages

For 446 (in)			For 446M (mm)		
Part No.	EDP	Size	Part No.	EDP	Size
PT99381	72211	0-1"	PT99391	72217	0-25mm
PT99382	72212	1-2"	PT99392	72218	25-50mm
PT99383	72213	2-3"	PT99393	72219	50-75mm
PT99384	72214	3-4"	PT99394	72220	75-100mm
PT99385	72215	4-5"	PT99395	72221	100-125mm
PT99386	72216	5-6"	PT99396	72222	125-150mm

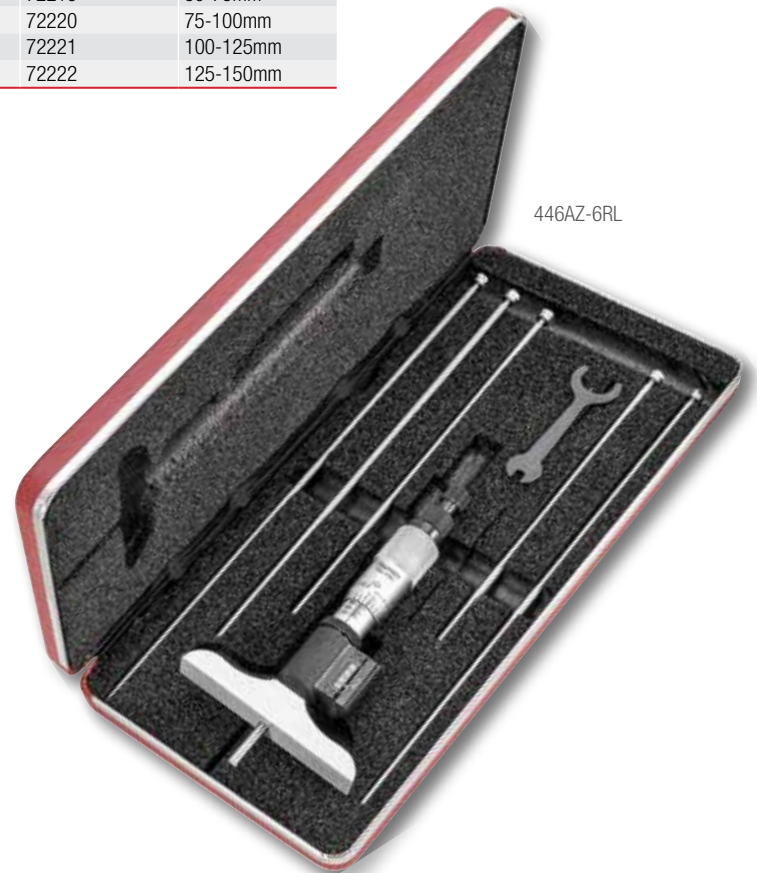

446AZ-6RL





DEPTH MICROMETERS

449 MICROMETER DEPTH GAGES WITH NON-ROTATING BLADES

0-6"/0-150MM

By holding the base in one hand, the .045" thick x 1/8" wide (1.2 x 3.2mm) blade can be turned with the fingers and positioned at any angle relative to the base. In operation, blade does not turn, but moves perpendicularly only, permitting depth measurement of narrow shoulders without the blade rolling off. This is also ideal for slots and recesses as narrow as .045" (1.2mm). Furnished with a 2-1/2" (63mm) or a 4" (100mm) base.

Also available with 3 rods for measuring 0-3" (0-75mm), or 6 rods for measuring 0-6" (0-150mm) in thousandths of an inch or 0.01mm.

This tool comes with the combination ratchet and speeder for uniform pressure and quicker adjustment.

449 Micrometer Depth Gages (.001" Graduation)

Cat. No.	EDP	Range	Base Length	Rods	Rod Size
449AZ-3R	52318	0-3"	2-1/2"	3	.045 x 1/8"
449AZ-6R	52320	0-6"	2-1/2"	6	
449BZ-3R	52322	0-3"	4"	3	
449BZ-6R	52324	0-6"	4"	6	

449M Micrometer Depth Gages (0.01mm Graduation)

Cat. No.	EDP	Range	Base Length	Rods	Rod Size
449MAZ-75R	56636	0-75mm	63.5mm	3	1.2 x 3.2mm
449MAZ-150R	56637	0-150mm	63.5mm	6	
449MBZ-75R	56638	0-75mm	100mm	3	
449MBZ-150R	56639	0-150mm	100mm	6	

Rods Only for 449M Micrometer Depth Gages

For 449 (in)			For 449M (mm)		
Part No.	EDP	Size	Part No.	EDP	Size
PT99306	72476	0-1"	PT99115	71838	0-25mm
PT99307	72477	1-2"	PT99116	71839	25-50mm
PT99308	72478	2-3"	PT99117	71840	50-75mm
PT99309	72479	3-4"	PT99118	71841	75-100mm
PT99310	72480	4-5"	PT99119	71842	100-125mm
PT99311	72481	5-6"	PT99120	71843	125-150mm

Longer rods are available by special order.



449AZ-3R



DEPTH MICROMETERS

440, 445 DEPTH MICROMETERS

0-9" AND 0-12"/0-225MM

- The depths of holes, slots, shoulders and projections can be measured to .001" or 0.01mm with these fine tools
- 440 Gages furnished with a 2-1/2" (63.5mm) base and 1/8" (3.2mm) diameter measuring rods
- 445 Gages furnished with choices of 3" (75mm), 4" (100mm), and 6" (150mm) bases and have 5/32" (4mm) diameter measuring rods
- Combination ratchet and speeder for uniform pressure and quicker adjustment
- Ring-type lock nut for quick and sure locking



445AZ-6RL



440-3L



445AZRL

440, 445 Depth Micrometers

Cat. No.	EDP	Range	Base	Rods	Rod Dia.
440Z-3L	52113	0-3"		3	
440Z-6L	52117	0-6"	2-1/2"	6	1/8"
440Z-9L	52121	0-9"		9	
440Z-3RL	52115	0-3"		3	
440Z-6RL	52119	0-6"	2-1/2"	6	1/8"
440Z-9RL	52123	0-9"		9	
445AZ-3RL	52208	0-3"		3	
445AZ-6RL	52212	0-6"	3"	6	5/32"
445AZ-9RL	52216	0-9"		9	
445AZ-12RL	67117	0-12"		12	
445BZ-3RL	52220	0-3"		3	
445BZ-6RL	52224	0-6"	4"	6	5/32"
445BZ-9RL	52228	0-9"		9	
445BZ-12RL	67118	0-12"		12	
445DZ-3RL	52244	0-3"		3	
445DZ-6RL	52248	0-6"	6"	6	5/32"
445DZ-9RL	52252	0-9"		9	
445DZ-12RL	67119	0-12"		12	

440M, 445M Depth Micrometers

Cat. No.	EDP	Range	Base	Rods	Rod Dia.
440MZ-75RL	52116	0-75mm		3	
440MZ-150RL	52120	0-150mm	63.5mm	6	3.2mm
440MZ-225RL	52124	0-225mm		9	
445MAZ-75RL	52209	0-75mm		3	
445MAZ-150RL	52213	0-150mm	75mm	6	4mm
445MAZ-225RL	52217	0-225mm		9	
445MBZ-75RL	52221	0-75mm		3	
445MBZ-150RL	52225	0-150mm	100mm	6	4mm
445MBZ-225RL	52229	0-225mm		9	
445MDZ-75RL	52245	0-75mm		3	
445MDZ-150RL	52249	0-150mm	150mm	6	4mm
445MDZ-225RL	52253	0-225mm		9	

Inch Reading Rods Only

Fits 440 Models		Fits 445 Models		Size
Part No.	EDP	Part No.	EDP	
PT99331	71973	PT99341	71982	0-1"
PT99332	71974	PT99342	71983	1-2"
PT99333	71975	PT99343	71984	2-3"
PT99334	71976	PT99344	71985	3-4"
PT99335	71977	PT99345	71986	4-5"
PT99336	71978	PT99346	71987	5-6"
PT99337	71979	PT99347	71988	6-7"
PT99338	71980	PT99348	71989	7-8"
PT99339	71981	PT99349	71990	8-9"
		PT99358	66673	9-10"
		PT99359	66674	10-11"
		PT99360	66675	11-12"

Millimeter Reading Rods Only

Fits 440M Models		Fits 445M Models		Size
Part No.	EDP	Part No.	EDP	
PT99361	72193	PT99371	72202	0-25mm
PT99362	72194	PT99372	72203	25-50mm
PT99363	72195	PT99373	72204	50-75mm
PT99364	72196	PT99374	72205	75-100mm
PT99365	72197	PT99375	72206	100-125mm
PT99366	72198	PT99376	72207	125-150mm
PT99367	72199	PT99377	72208	150-175mm
PT99368	72200	PT99378	72209	175-200mm
PT99369	72201	PT99379	72210	200-225mm

Longer rods available by special order.

DEPTH MICROMETERS

443 MICROMETER DEPTH GAGES WITH HALF BASE

0-9"

- Exactly like the 445 Micrometer except that it has a half base
- 2" (50mm) half base permits measuring depths of holes and slots close to shoulders and between obstructions
- Rods have individual length adjustment and are 5/32" (4mm) in diameter

443 Micrometer Depth Gages				
Cat. No.	EDP	Range	No. of Rods	Graduation
443Z-3RL	52171	0-3"	3	
443Z-6RL	52173	0-6"	6	.001"
443Z-9RL	52175	0-9"	9	

Inch Reading Rods Only		
443 Models		
Part No.	EDP	Size
PT99341	71982	0-1"
PT99342	71983	1-2"
PT99343	71984	2-3"
PT99344	71985	3-4"
PT99345	71986	4-5"
PT99346	71987	5-6"
PT99347	71988	6-7"
PT99348	71989	7-8"
PT99349	71990	8-9"
PT99358	66673	9-10"
PT99359	66674	10-11"
PT99360	66675	11-12"



690

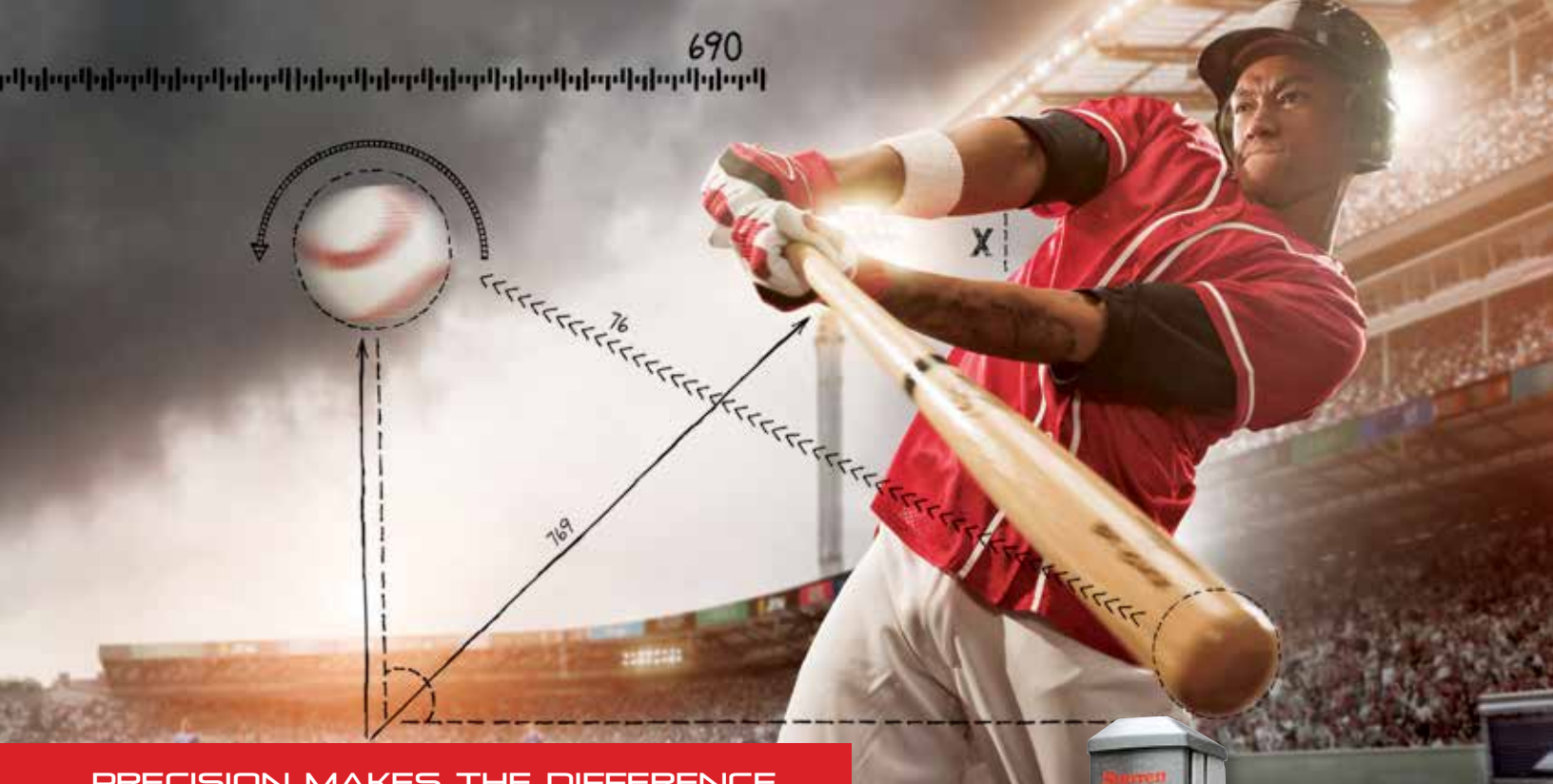

PRECISION MAKES THE DIFFERENCE

EXCEED YOUR CAPABILITIES.

The Starrett FMS incorporates new performance-based capabilities and user-friendly features to help you perform critical force tests with greater accuracy and efficiency.

It can perform all of your basic force measurement tests, as well as more complex multi-stage tests to international standards.



Model FMS5000

Starrett®

(978) 249-3551 • starrett.com

Follow us!

